

AGENDA

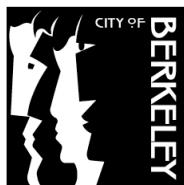

BERKELEY CITY COUNCIL MEETING

**Tuesday, April 23, 2019
6:00 PM**

SCHOOL DISTRICT BOARD ROOM - 1231 ADDISON STREET, BERKELEY, CA 94702

JESSE ARREGUIN, MAYOR

Councilmembers:

DISTRICT 1 – RASHI KESARWANI
DISTRICT 2 – CHERYL DAVILA
DISTRICT 3 – BEN BARTLETT
DISTRICT 4 – KATE HARRISON

DISTRICT 5 – SOPHIE HAHN
DISTRICT 6 – SUSAN WENGRAF
DISTRICT 7 – RIGEL ROBINSON
DISTRICT 8 – LORI DROSTE

This meeting will be conducted in accordance with the Brown Act, Government Code Section 54953. Any member of the public may attend this meeting. Questions regarding this matter may be addressed to Mark Numainville, City Clerk, 981-6900.

The City Council may take action related to any subject listed on the Agenda. The Mayor may exercise a two minute speaking limitation to comments from Councilmembers. Meetings will adjourn at 11:00 p.m. - any items outstanding at that time will be carried over to a date/time to be specified.

Preliminary Matters

Roll Call:

Ceremonial Matters: *In addition to those items listed on the agenda, the Mayor may add additional ceremonial matters.*

1. Recognition of Osha Neumann
2. Holocaust Remembrance Day
3. Presentation: Alameda County Mosquito Abatement District
4. Adjourned in Memory of Sue Hone, Former Berkeley City Councilmember

City Manager Comments: *The City Manager may make announcements or provide information to the City Council in the form of an oral report. The Council will not take action on such items but may request the City Manager place a report on a future agenda for discussion.*

Public Comment on Non-Agenda Matters: *Persons will be selected by lottery to address matters not on the Council agenda. If five or fewer persons submit speaker cards for the lottery, each person selected will be allotted two minutes each. If more than five persons submit speaker cards for the lottery, up to ten persons will be selected to address matters not on the Council agenda and each person selected will be allotted one minute each. Persons wishing to address the Council on matters not on the*

Council agenda during the initial ten-minute period for such comment, must submit a speaker card to the City Clerk in person at the meeting location and prior to commencement of that meeting. The remainder of the speakers wishing to address the Council on non-agenda items will be heard at the end of the agenda. Speaker cards are not required for this second round of public comment on non-agenda matters.

Consent Calendar

The Council will first determine whether to move items on the agenda for “Action” or “Information” to the “Consent Calendar”, or move “Consent Calendar” items to “Action.” Items that remain on the “Consent Calendar” are voted on in one motion as a group. “Information” items are not discussed or acted upon at the Council meeting unless they are moved to “Action” or “Consent”.

No additional items can be moved onto the Consent Calendar once public comment has commenced. At any time during, or immediately after, public comment on Information and Consent items, any Councilmember may move any Information or Consent item to “Action.” Following this, the Council will vote on the items remaining on the Consent Calendar in one motion.

For items moved to the Action Calendar from the Consent Calendar or Information Calendar, persons who spoke on the item during the Consent Calendar public comment period may speak again at the time the matter is taken up during the Action Calendar.

Public Comment on Consent Calendar and Information Items Only: *The Council will take public comment on any items that are either on the amended Consent Calendar or the Information Calendar. Speakers will be entitled to two minutes each to speak in opposition to or support of Consent Calendar and Information Items. A speaker may only speak once during the period for public comment on Consent Calendar and Information items.*

Additional information regarding public comment by City of Berkeley employees and interns: Employees and interns of the City of Berkeley, although not required, are encouraged to identify themselves as such, the department in which they work and state whether they are speaking as an individual or in their official capacity when addressing the Council in open session or workshops.

Consent Calendar

1. Cannabis Ordinance Revisions; Amending the Berkeley Municipal Code From: City Manager

Recommendation: Adopt second reading of Ordinance Nos. 7,645-N.S., 7,646-N.S., 7,647-N.S., 7,648-N.S., and 7,649-N.S., amending the Berkeley Municipal Code (BMC) which would:

1. Clarify cannabis business operational standards and development standards, such as quotas and buffers, for all cannabis business types;
2. Revise ordinance language to reflect State regulations;
3. Create a path to allow a new business type (Retail Nursery Microbusinesses); and
4. Protect youth by restricting cannabis advertising within the city.

The ordinances would adopt BMC Chapters 12.21 and 20.40, amend Chapters 12.22, and 23C.25, Sub-Titles 23E and 23F, and repeal Chapters 12.23, 12.25 and 12.27.

First Reading Vote: Ayes – Kesarwani, Davila, Bartlett, Harrison, Hahn, Wengraf, Robinson, Arreguin; Noes – None; Abstain - None; Absent - Droste.

Financial Implications: See report

Contact: Timothy Burroughs, Planning and Development, 981-7400

Consent Calendar

- 2. Contract: Masayuki Nagase for North Berkeley Senior Center Measure T1 Public Art Commission**
From: City Manager
Recommendation: Adopt a Resolution authorizing the City Manager to execute a contract for an amount not to exceed \$100,000, and any amendments thereto, with Masayuki Nagase for a public art commission for North Berkeley Senior Center.
Financial Implications: Public Art Fund - \$100,000
Contact: Jordan Klein, Economic Development, 981-7530
- 3. Formal Bid Solicitations and Request for Proposals Scheduled for Possible Issuance After Council Approval on April 23, 2019**
From: City Manager
Recommendation: Approve the request for proposals or invitation for bids (attached to staff report) that will be, or are planned to be, issued upon final approval by the requesting department or division. All contracts over the City Manager's threshold will be returned to Council for final approval.
Financial Implications: Various Funds - \$5,680,000
Contact: Henry Oyekanmi, Finance, 981-7300
- 4. Purchase Orders for Crayon Inc.: Using Riverside County's Joint Volume Licensing Program to Renew Microsoft's Enterprise Agreement**
From: City Manager
Recommendation: Adopt a Resolution authorizing the City Manager to execute a three-year renewal of the City's "Enterprise Agreement" (EA) for Microsoft licenses purchased through Crayon Inc., utilizing a cooperative purchasing agreement established by the County of Riverside's joint volume licensing program for the period beginning May 1, 2019 through April 30, 2022 for an amount not-to-exceed (NTE) \$2,968,000.
Financial Implications: Various Funds - \$2,968,000
Contact: Savita Chaudhary, Information Technology, 981-6500
- 5. Contract No. 118499-1 Amendment: Civic Makers, LLC for FUND\$ Replacement Change Management Support Services**
From: City Manager
Recommendation: Adopt a Resolution authorizing the City Manager to amend Contract No. 118499-1 with Civic Makers, LLC for extension of FUND\$ Replacement related Change Management Support Services, increasing the amount by \$400,000, for a total not to exceed \$529,025 from December 1, 2017 to June 30, 2021.
Financial Implications: FUND\$ Replacement Fund - \$400,000
Contact: Savita Chaudhary, Information Technology, 981-6500

Consent Calendar

- 6. Donation: Memorial Bench at Cesar Chavez Park in memory of Julio Costa Furtado**
From: City Manager
Recommendation: Adopt a Resolution accepting a cash donation in the amount of \$3,400 for a memorial bench to be placed at Cesar Chavez Park at the Berkeley Marina in memory of Julio Costa Furtado.
Financial Implications: Marina Fund - \$3,400 (donation)
Contact: Scott Ferris, Parks, Recreation and Waterfront, 981-6700
- 7. Donation: Memorial Bench at Cesar Chavez Park in memory of Barry Wofsy**
From: City Manager
Recommendation: Adopt a Resolution accepting a cash donation in the amount of \$3,400 for a memorial bench to be placed at Cesar Chavez Park at the Berkeley Marina in memory of Barry Wofsy.
Financial Implications: Marina Fund - \$3,400 (donation)
Contact: Scott Ferris, Parks, Recreation and Waterfront, 981-6700
- 8. Donation: Information Display Case at the Berkeley Rose Garden**
From: City Manager
Recommendation: Adopt a Resolution accepting a donation of an information display case valued at \$7,429 from the Friends of the Berkeley Rose Garden.
Financial Implications: \$7,429 (donation)
Contact: Scott Ferris, Parks, Recreation and Waterfront, 981-6700
- 9. Grant Application: Cosco Busan Round 2 Grant Program from the National Fish and Wildlife Foundation**
From: City Manager
Recommendation: Adopt a Resolution authorizing the City Manager or her designee to: submit a grant application in the amount of \$182,000 to the National Fish and Wildlife Foundation for the Cosco Busan Round 2 Grant Program; accept any grants; execute any resulting grant agreements and any amendments; and that Council authorize the implementation of the project and appropriation of funding for related expenses, subject to securing the grant.
Financial Implications: See report
Contact: Scott Ferris, Parks, Recreation and Waterfront, 981-6700
- 10. Contract No. 9668 Amendment: Serological Research Institute for DNA Testing Services**
From: City Manager
Recommendation: Adopt a Resolution authorizing the City Manager to amend Contract No. 9668 and any necessary future amendments with Serological Research Institute (SERI) for the Police Department, increasing the contract amount by \$250,000 for a total not to exceed amount of \$750,000 and a contract term extension for three additional years until June 30, 2022.
Financial Implications: State Proposition 172 Fund - \$250,000
Contact: Andrew Greenwood, Police, 981-5900

Consent Calendar

- 11. Contract: Bay Cities Paving & Grading, Inc. for Street Rehabilitation & Surface Seals FY 2019 Project**
From: City Manager
Recommendation: Adopt a Resolution approving plans and specifications for the Street Rehabilitation & Surface Seals Project, Specification No. 19-11271-C; accepting the bid of Bay Cities Paving & Grading, Inc. as the lowest responsive and responsible bidder; and authorizing the City Manager to execute a contract and any amendments, extensions or other change orders until completion of the project in accordance with the approved plans and specifications in an amount not to exceed \$5,688,307.
Financial Implications: Various Funds - \$5,688,307
Contact: Phillip Harrington, Public Works, 981-6300
- 12. Contract No. 10276A Amendment: Interface Engineering, Inc. for On-Call Electrical Engineering Services**
From: City Manager
Recommendation: Adopt a Resolution authorizing the City Manager to execute an amendment to the contract with Interface Engineering, Inc., Contract No. 10276A, for on-call electrical engineering consulting services, increasing the contract amount by \$90,000, for an amount not-to-exceed \$220,000, and extending the contract from June 30, 2019 to June 30, 2020.
Financial Implications: Various Funds - \$90,000
Contact: Phillip Harrington, Public Works, 981-6300
- 13. Authorize Negotiation in the Open Market for the FY2018 Measure M Low Impact Development (LID) Woolsey Street Project, Specification 18-11183-C**
From: City Manager
Recommendation: Adopt a Resolution: 1. accepting staff report that no bids were received when Specification No. 18-11183-C, FY2018 Measure M Low Impact Development Woolsey Street Project was re-advertised; and 2. authorizing the City Manager to negotiate in the open market in accordance with Article XI, Public Works and Supplies, Section 67(a.) of the City Charter.
Financial Implications: See report
Contact: Phillip Harrington, Public Works, 981-6300
- 14. Resources for Community Development's 2001 Ashby Avenue Predevelopment Loan Application**
From: Housing Advisory Commission
Recommendation: Authorize funding for the Resources for Community Development (RCD) predevelopment loan application for \$368,000 for its proposed development at 2001 Ashby Avenue.
Financial Implications: See report
Contact: Amy Davidson, Commission Secretary, 981-5400

Consent Calendar

- 15. Senate Constitutional Amendment 1 and Assembly Bill 10**
From: Housing Advisory Commission
Recommendation: Endorse Senate Constitutional Amendment (SCA) 1 and Assembly Bill (AB) 10.
Financial Implications: See report
Contact: Amy Davidson, Commission Secretary, 981-5400

Council Consent Items

- 16. Authorize Sending a Letter of Support for AB-953 “Cannabis: state and local taxes: payment by digital asset” to Assemblymember Phil Ting**
From: Councilmember Bartlett
Recommendation: That the City Council authorize sending a letter of support for AB-953 to Assemblymember Ting. AB-953 will allow state and local tax authorities to collect cannabis-generated taxes via stable digital currencies. This will help to address legal cannabis businesses’ underbanking problem.
Financial Implications: Minimal
Contact: Ben Bartlett, Councilmember, District 3, 981-7130
- 17. The Center for Food, Faith, and Justice and Green the Church: Relinquishment of Council Office Budget Fund to General Fund and Grant of Such Funds**
From: Councilmembers Bartlett and Davila
Recommendation: Adopt a resolution approving the expenditure of an amount not to exceed \$500 per council member, including \$500 from Councilmember Bartlett, to the “Black, Green, and Traumatized: Environmental Trauma and Mental Health” event hosted by The Center for Food, Faith, and Justice and Green the Church on April 27th from 10am-3pm at McGee Avenue Baptist Church, 1640 Stuart Street, Berkeley, CA 94703. The funds will be relinquished to the city’s general fund for this purpose from the discretionary council office budget of Councilmember Ben Bartlett and any other council members who would like to contribute.
Financial Implications: Councilmember's Discretionary Funds - \$500
Contact: Ben Bartlett, Councilmember, District 3, 981-7130
- 18. Black Repertory Group Theater: Relinquishment of Council Office Budget Fund to General Fund and Grant of Such Funds**
From: Councilmembers Bartlett and Davila
Recommendation: Adopt a resolution approving the expenditure of an amount not to exceed \$3,000 per council member, including \$3,000 from Councilmember Bartlett, to the Black Repertory Group, with funds relinquished to the city’s general fund for this purpose from the discretionary council office budget of Councilmember Ben Bartlett and any other council members who would like to contribute.
Financial Implications: Councilmember's Discretionary Funds - \$3,000
Contact: Ben Bartlett, Councilmember, District 3, 981-7130

Council Consent Items

19. **U1 Funds for Predevelopment Costs of Proposed Development at 2001 Ashby Avenue**
From: Councilmember Bartlett and Mayor Arreguin
Recommendation: Adopt a Resolution allocating \$368,000 of General Funds from Measure U1 tax receipts to Resources for Community Development (RCD) for predevelopment costs at 2001 Ashby Avenue.
Financial Implications: See report
Contact: Ben Bartlett, Councilmember, District 3, 981-7130
20. **Budget Referral: Good Government Ombudsman**
From: Councilmembers Harrison and Davila
Recommendation: Refer to the 2019/2020 budget process to establish a Good Government Ombudsman to facilitate enforcement of Berkeley's good government laws through the City Clerk and City Attorney's Office.
Financial Implications: See report
Contact: Kate Harrison, Councilmember, District 4, 981-7140
21. **Support for Zero Emission Bills**
From: Councilmembers Harrison, Davila, Hahn, and Robinson
Recommendation:
1. Adopt a resolution of support for two bills that will move California towards eliminating greenhouse gas emissions from the transportation sector: AB 40, which calls for all cars sold in California to be zero-emission by 2040, and AB 1418, which calls for all public school buses in California to be zero-emission by 2030.
2. Send letter of support to Senator Skinner and Assemblymember Wicks.
Financial Implications: None
Contact: Kate Harrison, Councilmember, District 4, 981-7140
22. **Adopt an Ordinance Adding Chapter 13.104 to the Berkeley Municipal Code Establishing a Prohibition on Contracting with Vendors Acting as U.S. Immigration and Customs Enforcement (ICE) Data Brokers, or Those Providing Extreme Vetting Services to ICE** *(Reviewed by the Agenda and Rules Committee)*
From: Councilmembers Harrison, Davila, and Bartlett
Recommendation: That the City Council adopt the attached Sanctuary Contracting Ordinance as amended. This ordinance prohibits the award of city contracts to vendors acting as U.S. Immigration and Customs Enforcement data brokers, or those providing extreme vetting services.
Financial Implications: See report
Contact: Kate Harrison, Councilmember, District 4, 981-7140

Council Consent Items

- 23. Resolution in Support of a Public Bank**
From: Councilmembers Harrison, Davila, and Robinson, and Mayor Arreguin
Recommendation: Adopt a resolution affirming Berkeley's support for public banking and send that resolution to Governor Newsom, Senator Skinner, and Assemblymember Wicks urging state legislation to enable local agencies to create public banks.
Financial Implications: See report
Contact: Kate Harrison, Councilmember, District 4, 981-7140
- 24. Letters In Support of SB 54 (Allen) and AB 1080 (Gonzalez)**
From: Councilmember Wengraf, Mayor Arreguin, and Councilmembers Hahn and Bartlett
Recommendation: Send a letter of support for SB 54 (Allen) and AB 1080 (Gonzalez) to Senator Ben Allen and Assemblywoman Lorena Gonzalez with copies to Senator Skinner, Assembly Member Wicks and Governor Newsom
Financial Implications: None
Contact: Susan Wengraf, Councilmember, District 6, 981-7160
- 25. Co-Sponsor the Screening of "Near Normal Man"**
From: Councilmember Wengraf, Mayor Arreguin, and Councilmembers Bartlett and Hahn
Recommendation: That the City of Berkeley become an official co-sponsor of the screening and discussion of "Near Normal Man" on April 29th at Berkeley City College
Financial Implications: None
Contact: Susan Wengraf, Councilmember, District 6, 981-7160
- 26. Support for SB 188 (Hairstyle Anti-Discrimination Law)**
From: Councilmembers Robinson, Davila, and Bartlett
Recommendation: Send a letter to Senator Mitchell, Senator Skinner, and Assemblymember Wicks supporting SB 188, which would amend the California Fair Employment and Housing Act to prohibit racial discrimination on the basis of hairstyle.
Financial Implications: None
Contact: Rigel Robinson, Councilmember, District 7, 981-7170

Council Consent Items

- 27. Support for ACA-1: Local Government Financing: Affordable Housing and Public Infrastructure: Voter Approval**
From: Councilmembers Robinson, Bartlett, and Harrison
Recommendation: Adopt a resolution supporting ACA-1, which would allow local governments to raise property taxes to fund bonds for the purposes of financing public infrastructure and affordable housing projects, as well as reducing the required vote threshold to authorize certain local special taxes for the purpose of funding public infrastructure and affordable housing. Copies of the resolution to be sent to Senator Nancy Skinner, Assemblymember Buffy Wicks, and Assemblymember Aguiar-Curry.
Financial Implications: None
Contact: Rigel Robinson, Councilmember, District 7, 981-7170
- 28. Support for AB 273 and AB 44: Prohibit Fur Trapping and Sales**
From: Councilmembers Robinson and Harrison
Recommendation: Adopt a resolution supporting Fish and Game Code amendment AB 273, which prohibits the trapping of fur-bearing and nongame mammals for recreational or commercial purposes, and AB 44, which amends the Fish and Game Code to prohibit the sale of fur products statewide.
Financial Implications: None
Contact: Rigel Robinson, Councilmember, District 7, 981-7170
- 29. Refer to the City Manager and the Housing Advisory Commission to Consider Reforming the Affordable Housing Mitigation Fee** *(Reviewed by the Land Use, Housing & Economic Development Committee)*
From: Councilmembers Robinson and Hahn, Mayor Arreguin, and Councilmember Droste
Recommendation: Refer to the City Manager, the Planning Commission, and the Housing Advisory Commission to consider possible reforms to the Affordable Housing Mitigation Fee, including adopting a per-square-foot fee structure, potentially on a geographic basis.
Financial Implications: See report
Contact: Rigel Robinson, Councilmember, District 7, 981-7170

Council Consent Items

- 30. Relinquishment of Council Office Budget Funds: “Post-Memory: A Decade of Art and Activism in Berkeley,” an art exhibit in honor of Zachary Cruz**
From: Councilmembers Droste, Davila, and Robinson
Recommendation: Adopt a Resolution approving the expenditure of an amount not to exceed \$250 per sponsoring Councilmember, with funds relinquished from the discretionary Council Office Budgets of Councilmember Droste and any other Councilmembers who would like to contribute. Funds would go to cover the costs of the art exhibit “Post-Memory: A Decade of Art and Activism in Berkeley” at UC Berkeley. 2019 marks the ten year anniversary of the death of Zachary Cruz who died from road violence on Berkeley streets. The art exhibit will honor Zachary and raise awareness about road safety and Vision Zero in Berkeley. Additional details about the exhibit are attached. Donations will go to A to Z Families for Safe Streets, c/o Los Angeles Walks, 830 Traction Ave 3rd Floor, Los Angeles, CA 90013.
Financial Implications: Councilmember's Discretionary Funds - \$250
Contact: Lori Droste, Councilmember, District 8, 981-7180

Action Calendar

The public may comment on each item listed on the agenda for action as the item is taken up. For items moved to the Action Calendar from the Consent Calendar or Information Calendar, persons who spoke on the item during the Consent Calendar public comment period may speak again at the time the matter is taken up during the Action Calendar.

The Presiding Officer will request that persons wishing to speak line up at the podium to determine the number of persons interested in speaking at that time. Up to ten (10) speakers may speak for two minutes. If there are more than ten persons interested in speaking, the Presiding Officer may limit the public comment for all speakers to one minute per speaker. Speakers are permitted to yield their time to one other speaker, however no one speaker shall have more than four minutes. The Presiding Officer may, with the consent of persons representing both sides of an issue, allocate a block of time to each side to present their issue.

Action items may be reordered at the discretion of the Chair with the consent of Council.

Action Calendar – Public Hearings

Staff shall introduce the public hearing item and present their comments. This is followed by five-minute presentations each by the appellant and applicant. The Presiding Officer will request that persons wishing to speak, line up at the podium to be recognized and to determine the number of persons interested in speaking at that time.

Up to ten (10) speakers may speak for two minutes. If there are more than ten persons interested in speaking, the Presiding Officer may limit the public comment for all speakers to one minute per speaker. Speakers are permitted to yield their time to one other speaker, however no one speaker shall have more than four minutes. The Presiding Officer may with the consent of persons representing both sides of an issue allocate a block of time to each side to present their issue.

Each member of the City Council shall verbally disclose all ex parte contacts concerning the subject of the hearing. Councilmembers shall also submit a report of such contacts in writing prior to the commencement of the hearing. Written reports shall be available for public review in the office of the City Clerk.

Action Calendar – Public Hearings

31. **ZAB Appeal: 1722 Walnut St** *(Continued from March 26, 2019)*
From: City Manager
Recommendation: Conduct a public hearing, and upon conclusion adopt a Resolution to affirm the Zoning Adjustments Board decision to deny Use Permit/Variance #ZP2018-0021 to legalize an unpermitted detached dwelling unit in the rear yard area of a lot legally developed with an eight-unit apartment building, and dismiss the appeal.
Financial Implications: None
Contact: Timothy Burroughs, Planning and Development, 981-7400

Action Calendar – Old Business

32. **Missing Middle Housing Report** *(Continued from March 26, 2019. Item contains revised and supplemental material.)*
From: Councilmembers Droste, Bartlett, Robinson, and Kesarwani
Recommendation: Refer to the City Manager to prepare a report to the Council of examining methods, including potential revisions to the zoning code, that may foster a broader range housing types across Berkeley, particularly missing middle housing types (duplexes, triplexes/fourplexes, courtyard apartments, bungalow courts, townhouses, etc.), in areas with access to essential components of livability like parks, schools, employment, transit, and other services.
Given the range of requests included in this referral, it is expected that responding to the referral will require a combination of field research, consultation with design professionals and other cities and agencies, and community outreach and engagement. Council requests that staff initiate this work as soon as possible.
Financial Implications: See report
Contact: Lori Droste, Councilmember, District 8, 981-7180
33. **Adopt a Spot Initiative** *(Continued from April 2, 2019)*
From: Councilmembers Droste, Kesarwani, and Bartlett
Recommendation: Refer to the Public Works Commission and Parks and Waterfront Commission to develop an Adopt A Spot initiative; specifically outlining potential environmental benefits, program costs, staffing. Rationale: -Adopt a Spot programs enable a network of volunteer residents to assist in city maintenance and clean up efforts which have great impact using minimal City staff/funding. -Vision 2050 will include stormwater and watershed management goals, both of which this program would support.
Financial Implications: Staff time
Contact: Lori Droste, Councilmember, District 8, 981-7180

Action Calendar – New Business

- 34. Referral Response: Updated Policy for Emergency Standby Officers for the Mayor and Councilmembers** *(Reviewed by the Agenda and Rules Committee)*
From: City Manager
Recommendation: Adopt a Resolution updating the selection process and criteria for the appointment of Standby Officers for the Mayor and each Councilmember to serve in the event the elected official is unavailable during an emergency, and rescinding Resolution No. 57,906-N.S.
Financial Implications: None
Contact: Mark Numainville, City Clerk, 981-6900

Council Action Items

- 35. Paid Family Leave Policy in Berkeley to Supplement California Paid Family Leave Program**
From: Councilmembers Bartlett, Hahn, Harrison, and Davila
Recommendation: That the City Council adopt this policy and refer to the City Manager and City Attorney to amend the proposed ordinance based on the recommendations of the Paid Family Leave (PFL) Subcommittee and to conform to legal and code consistency requirements.
Financial Implications: See report
Contact: Ben Bartlett, Councilmember, District 3, 981-7130
- 36. Allocate \$400,000 from the Street and Open Space Improvement Fund for the Design and Construction of a Protected Milvia Bikeway Pilot Project between University Avenue and Allston Way**
From: Councilmember Harrison and Mayor Arreguin
Recommendation: Adopt a Resolution allocating \$400,000 from the Street and Open Space Improvement Fund (SOSIF) to design and construct a protected Milvia Bikeway pilot project between University Avenue and Allston Street.
Financial Implications: See report
Contact: Kate Harrison, Councilmember, District 4, 981-7140

Information Reports

- 37. Ethical Climate Audit Status Report**
From: City Manager
Contact: Paul Buddenhagen, City Manager's Office, 981-7000
- 38. Ambulance Billing Follow-up Audit Status Report**
From: City Manager
Contact: David Brannigan, Fire, 981-3473

Information Reports

39. **Status Report: City at Crossroads as Long-Standing Need for Structured Approach to Line of Business Experts Function Intersects with ERP Implementation**
From: City Manager
Contact: Savita Chaudhary, Information Technology, 981-6500
40. **LPO NOD: 2300 Shattuck Avenue, #LMSAP2019-0001**
From: City Manager
Contact: Timothy Burroughs, Planning and Development, 981-7400
41. **LPO NOD: 1414 Walnut Street/#LMSAP2018-0005 for the Former Garfield School**
From: City Manager
Contact: Timothy Burroughs, Planning and Development, 981-7400

Public Comment – Items Not Listed on the Agenda

Adjournment

NOTICE CONCERNING YOUR LEGAL RIGHTS: *If you object to a decision by the City Council to approve or deny a use permit or variance for a project the following requirements and restrictions apply: 1) No lawsuit challenging a City decision to deny (Code Civ. Proc. §1094.6(b)) or approve (Gov. Code 65009(c)(5)) a use permit or variance may be filed more than 90 days after the date the Notice of Decision of the action of the City Council is mailed. Any lawsuit not filed within that 90-day period will be barred. 2) In any lawsuit that may be filed against a City Council decision to approve or deny a use permit or variance, the issues and evidence will be limited to those raised by you or someone else, orally or in writing, at a public hearing or prior to the close of the last public hearing on the project.*

Live captioned broadcasts of Council Meetings are available on Cable B-TV (Channel 33), via internet accessible video stream at <http://www.cityofberkeley.info/CalendarEventWebcastMain.aspx> and KPFB Radio 89.3.

Archived indexed video streams are available at <http://www.cityofberkeley.info/citycouncil>. Channel 33 rebroadcasts the following Wednesday at 9:00 a.m. and Sunday at 9:00 a.m.

Communications to the City Council are public record and will become part of the City's electronic records, which are accessible through the City's website. **Please note: e-mail addresses, names, addresses, and other contact information are not required, but if included in any communication to the City Council, will become part of the public record.** If you do not want your e-mail address or any other contact information to be made public, you may deliver communications via U.S. Postal Service or in person to the City Clerk Department at 2180 Milvia Street. If you do not want your contact information included in the public record, please do not include that information in your communication. Please contact the City Clerk Department for further information.

Any writings or documents provided to a majority of the City Council regarding any item on this agenda will be made available for public inspection at the public counter at the City Clerk Department located on the first floor of City Hall located at 2180 Milvia Street as well as posted on the City's website at <http://www.cityofberkeley.info>.

Agendas and agenda reports may be accessed via the Internet at <http://www.cityofberkeley.info/citycouncil> and may be read at reference desks at the following locations:

City Clerk Department
2180 Milvia Street
Tel: 510-981-6900
TDD: 510-981-6903
Fax: 510-981-6901
Email: clerk@cityofberkeley.info

Libraries:
Main - 2090 Kittredge Street
Claremont Branch – 2940 Benvenue
West Branch – 1125 University
North Branch – 1170 The Alameda
South Branch – 1901 Russell

COMMUNICATION ACCESS INFORMATION:

This meeting is being held in a wheelchair accessible location.

To request a disability-related accommodation(s) to participate in the meeting, including auxiliary aids or services, please contact the Disability Services specialist at 981-6418 (V) or 981-6347 (TDD) at least three business days before the meeting date.

Attendees at public meetings are reminded that other attendees may be sensitive to various scents, whether natural or manufactured, in products and materials. Please help the City respect these needs.



Captioning services are provided at the meeting, on B-TV, and on the Internet. In addition, assisted listening devices for the hearing impaired are available from the City Clerk prior to the meeting, and are to be returned before the end of the meeting.

~~~~~  
*I hereby certify that the agenda for this meeting of the Berkeley City Council was posted at the display case located near the walkway in front of the Maudelle Shirek Building, 2134 Martin Luther King Jr. Way, as well as on the City's website, on April 11, 2019.*

A handwritten signature in black ink, appearing to read 'Mark Numainville'.

Mark Numainville, City Clerk

## Communications

*Council rules limit action on Communications to referral to the City Manager and/or Boards and Commissions for investigation and/or recommendations. All communications submitted to Council are public record. Copies of individual communications are available for viewing at the City Clerk Department and through Records Online.*

**Item #1: Cannabis Ordinance Revisions; Amending the Berkeley Municipal Code**

1. Sameen Ahmad, on behalf of High Times
2. Adria-Ann McMurray

**Item #36: Allocate \$400,000 from the Street and Open Space Improvement Fund for the Design and Construction of a Protected Milvia Bikeway Pilot Project between University Avenue and Allston Way**

3. Tom Buoye

**RV Ordinance**

4. Colin Palmquist
5. Jessica Behrman
6. Patricia and Lee Husted

**Housing**

7. Karen Westmont
8. Friends of Adeline
9. Donald Goldmacher
10. Russbumper

**BART**

11. Sharon Simburg
12. North Berkeley Neighborhood Alliance
13. Barbara Fisher

**Encampments**

14. Bernice Gross
15. Virginia Burton
16. Liz Ruhland

**5G**

17. Ben Burch
18. Vivian Warkentin
19. Phoebe Anne Sorgen
20. Susan Brinchman
21. Annamarta Dostourian

**Budget and Finance**

22. Kelly Hammargren
23. Barbara Gilbert
24. Isabell Gaston (2)
25. Janice Greenberg (3)
26. Jessica Behrman

**Berkeley Marina Liveboard**

27. Christina Lisac

**Help Needed on Francisco Street**

28. Mathew Rogers

**Berkeley Green Monday**

29. Amy Halpern-Laff

**Lake Merritt Pollution**

30. Richard Bailey

**East Bay Community Energy Meetings**

31. East Bay Community Energy

**Bay Area Poor People's Hearing**

32. Amanda Baldiga (2)

**"Bordertown" Berkeley/Oakland**

33. Janice Greenburg

**Opportunity Zones**

34. Barbara Gilbert

**Healthy City for All**

35. Suzanne Lennard

**Fund Rebuilding Together and Inter-City Services**

36. Thomas Lord

**Rail Safety and Rail Transit Related Problems**

37. Beth Gerstein, Legislative Aid for Councilmember Kesarwani

**Global Banks and Fossil Fuels**

38. Donald Goldmacher

**Community Activism Ideas**

39. David Dixon

**Reality**

40. Steve Kromer

**Hit and Run at Durant and Telegraph**

41. Max Ventura

42. Jonah Markowitz (2)

43. Christopher Kohler

**Council Meeting Broadcasts**

44. Janice Greenberg

45. Barbara Gilbert

**City Real Estate Transfer Tax**

46. Paul Weir and Maria Gimenez Cacho

**Berkeley Parks Closed**

47. Noah Nathan

**West Campus Pool**

48. Tobie Lurie

49. Francine and Gary Foltz

50. Donna Mickleson



51. Erica Buhrmann and Ron Drucker

**Marina Parking**

52. Jonathan Love and Satya Robinson

53. Joshua Morrill

54. Mayo & Robyn Ryan

**Toxic Fire Fighting Foam**

55. David Lerman

**Public Health**

56. Carol Denney

**EV Charging**

57. Elisa Mikiten

**Boards and Commissions Publishing Minutes**

58. Kelly Hammargren

**BPD Report on Stop Data**

59. Elliot Halpern

**Supplemental Communications and Reports**

*Items received by the deadlines for submission will be compiled and distributed as follows. If no items are received by the deadline, no supplemental packet will be compiled for said deadline.*

- **Supplemental Communications and Reports 1**  
Available by 5:00 p.m. five days prior to the meeting.
- **Supplemental Communications and Reports 2**  
Available by 5:00 p.m. the day before the meeting.
- **Supplemental Communications and Reports 3**  
Available by 5:00 p.m. two days following the meeting.



# Modern Mosquito Control Challenges and Opportunities

An Independent Special District  
Protecting Public Health since 1930

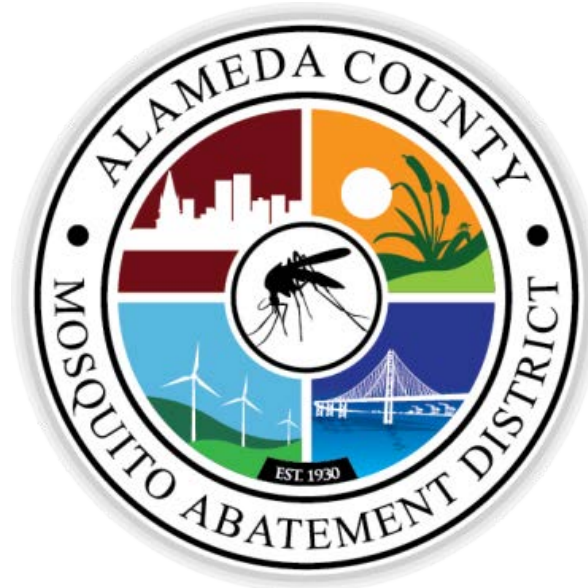

City of Berkeley: 4/23/19



# Hello Berkeley.

- Our District
- Mosquitoes
- Health Threats
- Control
- Innovations
- Partners



# Our Board of Trustees

**Eric Hentschke, President, City of Newark**

**Wendi Poulson, Vice-President, City of Alameda**

**P. Robert Beatty, Secretary, City of Berkeley**

Cathy Roache, County-at-Large

Alan Brown, City of Dublin

Betsy Cooley, City of Emeryville

George Young, City of Fremont

Elisa Marquez, City of Hayward

James N. Doggett, City of Livermore

Jan O. Washburn, City of Oakland

Robert Dickinson, City of Piedmont

Kathy Narum, City of Pleasanton

Victor Aguilar, City of San Leandro

Subru Bhat, City of Union City

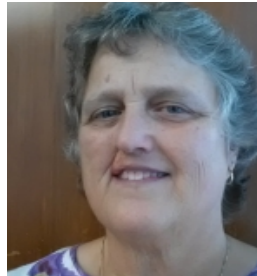

Page 4 of 29  
**Fixed Charges and/or Special Assessments**

| Description          | Phone        | Amount |
|----------------------|--------------|--------|
| CITY SEWER SERVICE   | 800-676-7516 | 313.80 |
| MOSQUITO ABATEMENT   | 800-273-5167 | 1.74   |
| CSA PARAMEDIC        | 800-441-8280 | 32.86  |
| CSA VECTOR CONTROL   | 800-273-5167 | 5.92   |
| HEALTHCARE DIST      | 800-273-5167 | 298.00 |
| CSA LEAD ABATEMENT   | 510-567-8280 | 10.00  |
| * SCHOOL MEASURE B1  | 844-332-0549 | 683.20 |
| PERALTA CCD MEAS B   | 800-792-8021 | 48.00  |
| SFBRA MEASURE AA     | 888-508-8157 | 12.00  |
| HAZ WASTE PROGRAM    | 800-273-5167 | 7.40   |
| CSA VECTOR CNTRL B   | 800-273-5167 | 4.08   |
| MOSQUITO ASSESS 2    | 800-273-5167 | 2.50   |
| AC TRANSIT MEAS VV   | 800-273-5167 | 96.00  |
| EBMUD WETWEATHER     | 866-403-2683 | 103.74 |
| * EAST BAY TRAIL LLD | 888-512-0316 | 5.44   |
| * EBRP PARK SAFETY/M | 888-512-0316 | 12.00  |
| URBAN RUNOFF         | 510-670-6615 | 56.14  |

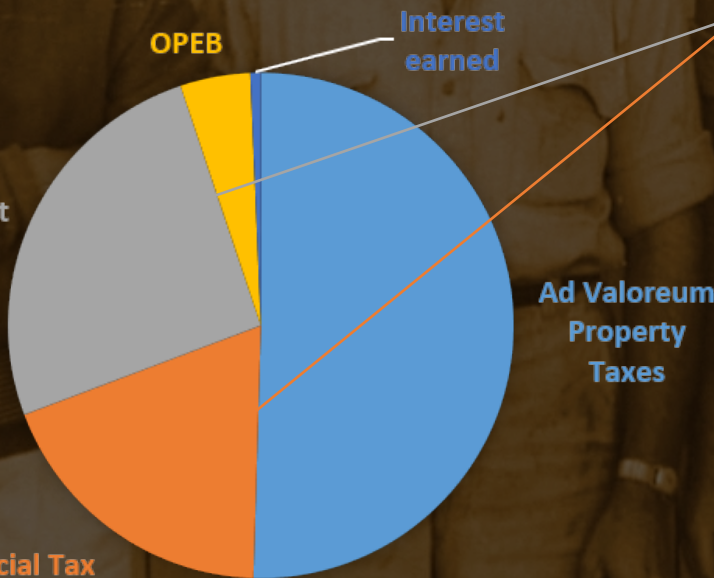

(.0009% of property tax assessed value)

# Financials

# Our Staff: *17 FT & 5 Seasonal Staff*

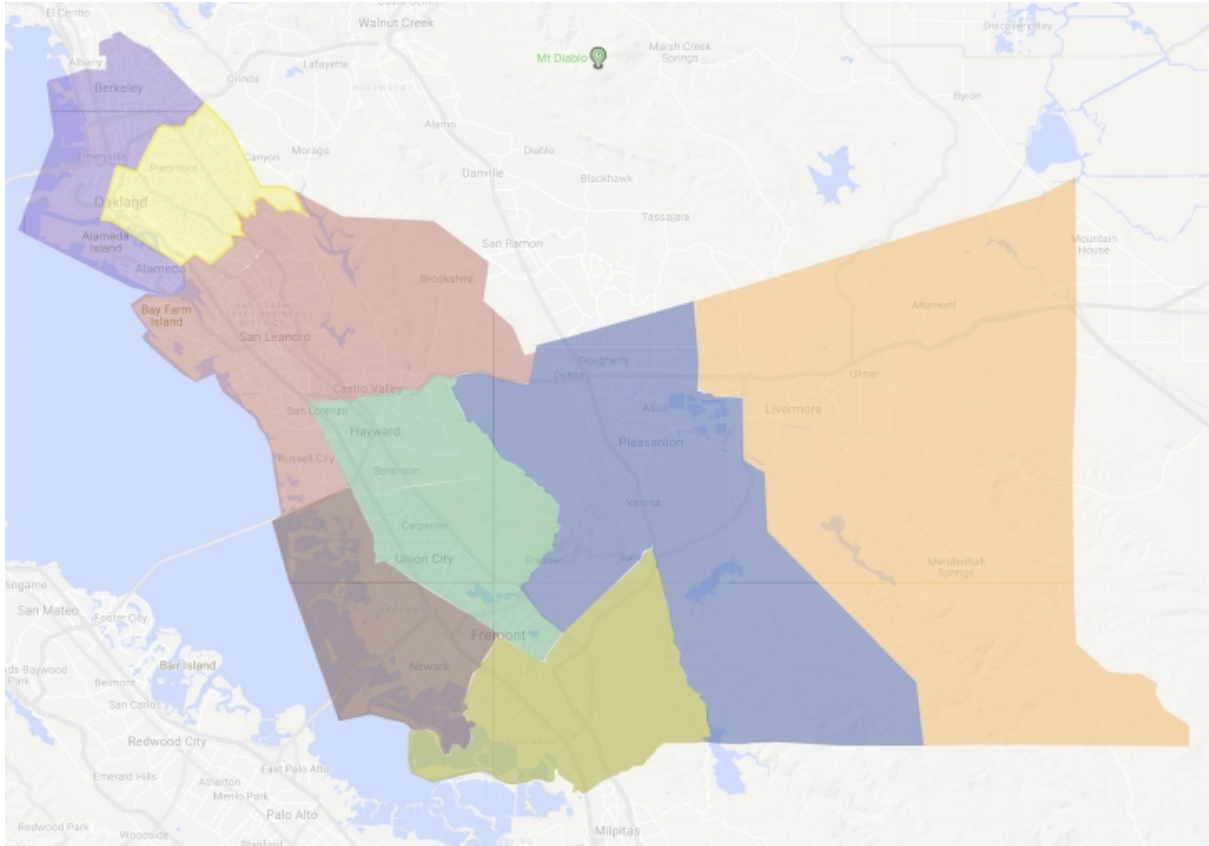

## Mosquito Control

9 FT Staff in 8 Zones  
2 Seasonal Staff

## Monitoring

3 FT Staff  
2 Seasonal Staff

## Administrative

5 FT Staff  
1 Seasonal Staff



# Aquatic Lifecycle

- Urban mosquitoes spend 1 - 2 weeks as larvae or pupae
- Breathe air at the surface of water

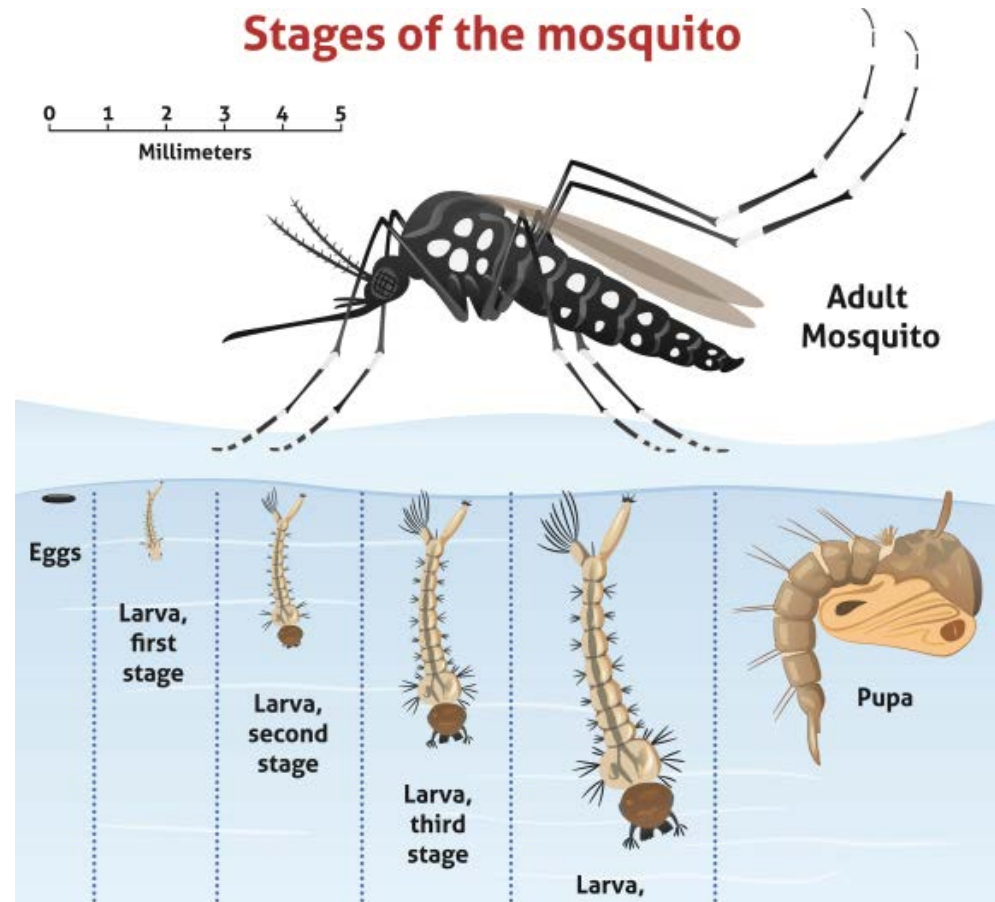



# Mosquito Pathogens

- West Nile virus
- Western equine encephalitis virus
- Saint Louis encephalitis virus
- Dog heartworm
- Malaria
- Zika virus
- Dengue virus
- Chikungunya virus
- Yellow fever virus

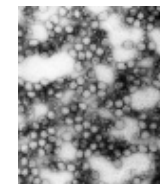
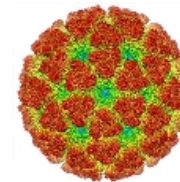
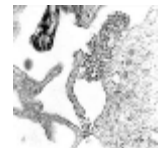
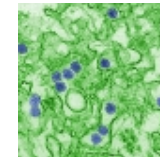
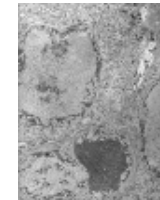
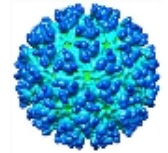

# Mosquitoes in Alameda County that transmit West Nile virus



*Culex pipiens*:  
common house mosquito



*Culex tarsalis*:  
western encephalitis mosquito



# Mosquitoes that spread Zika, Dengue, Chikungunya, Yellow Fever viruses

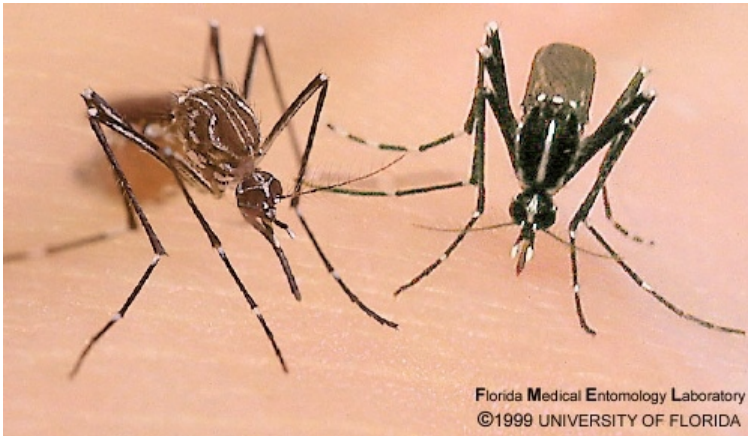

*Aedes aegypti*

lyre-shaped pattern on thorax

*Aedes albopictus*

bright lateral line on thorax

## *Aedes aegypti* and *Aedes albopictus* Mosquitoes in California Detection Sites by County/City

Updated December 7, 2018

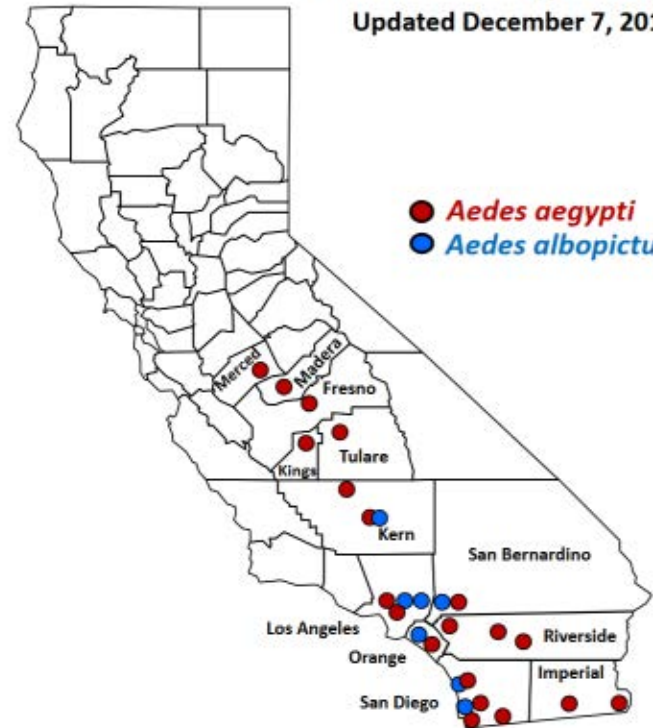

Counties with  
*Aedes aegypti* only:  
Fresno, Imperial, Kings,  
Madera, Riverside, Merced,  
Tulare

Both *Aedes aegypti* and  
*Aedes albopictus*:  
Kern, Los Angeles, Orange,  
San Bernardino, San Diego

See pages 2 and 3 for *Aedes*  
detections by city or census-  
designated place in each  
county.



# Controlling Mosquitoes



# Our Service Area and Monitoring Sites

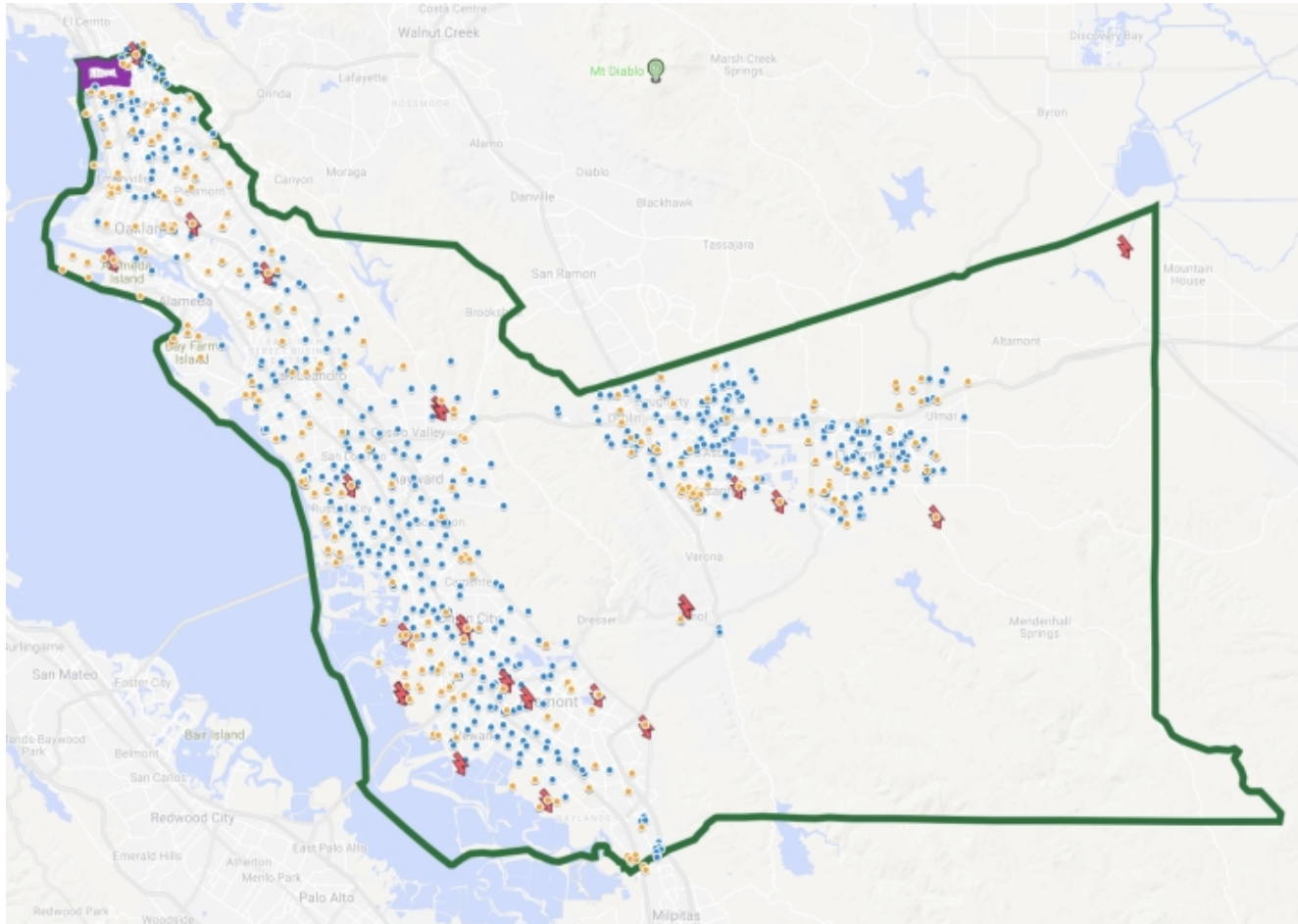

— County boundary

— Outside of service area

📍 Light traps  
(n = 22)

● Native mosquito traps  
(n = 180)

● Invasive *Aedes* traps  
(n = 710)



# Monitoring Approach

## Adult monitoring with traps

### Looking for larvae & eggs



# Testing for disease and insecticide resistance

we test more than 90 % of disease-spreading mosquitoes caught in our traps



sensitivity to insecticides

virus test results in 3 hours

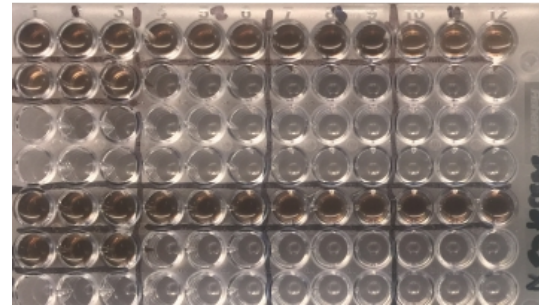

insecticide detoxification

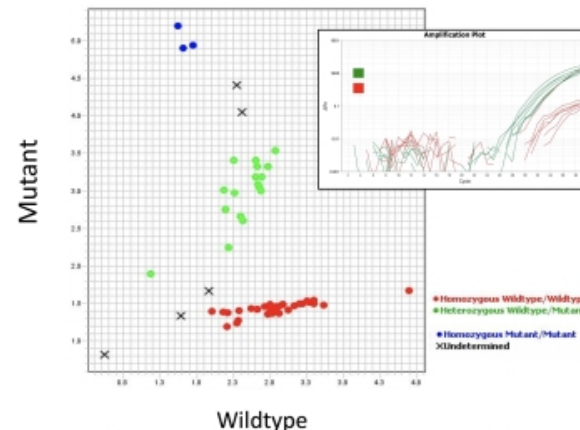
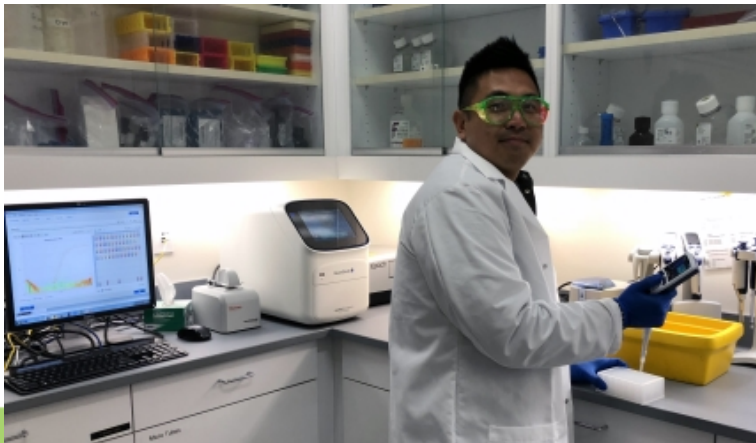

genetic resistance

# Controlling mosquitoes in storm drain systems





# Controlling mosquitoes in marshes



# Controlling mosquitoes with fish



# Controlling mosquitoes through source reduction



# Channels for community outreach

Legislative



Interagency

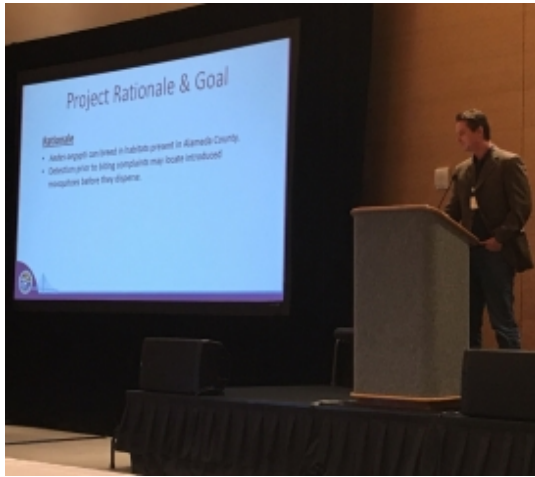

Public



@AlamedaMosquito



@AlamedaMosquito



AlamedaMosquito



# Quality Control & Automation

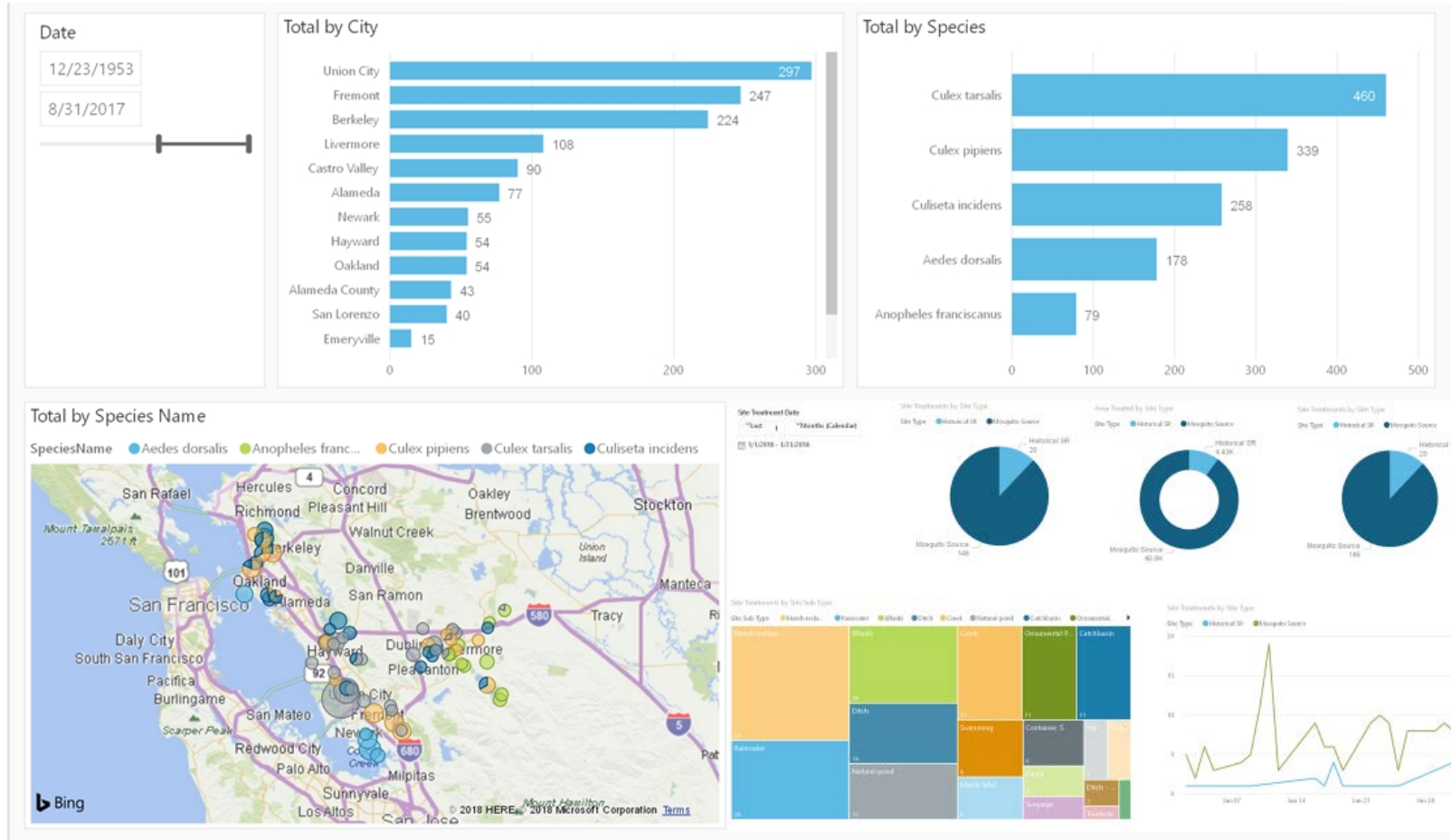

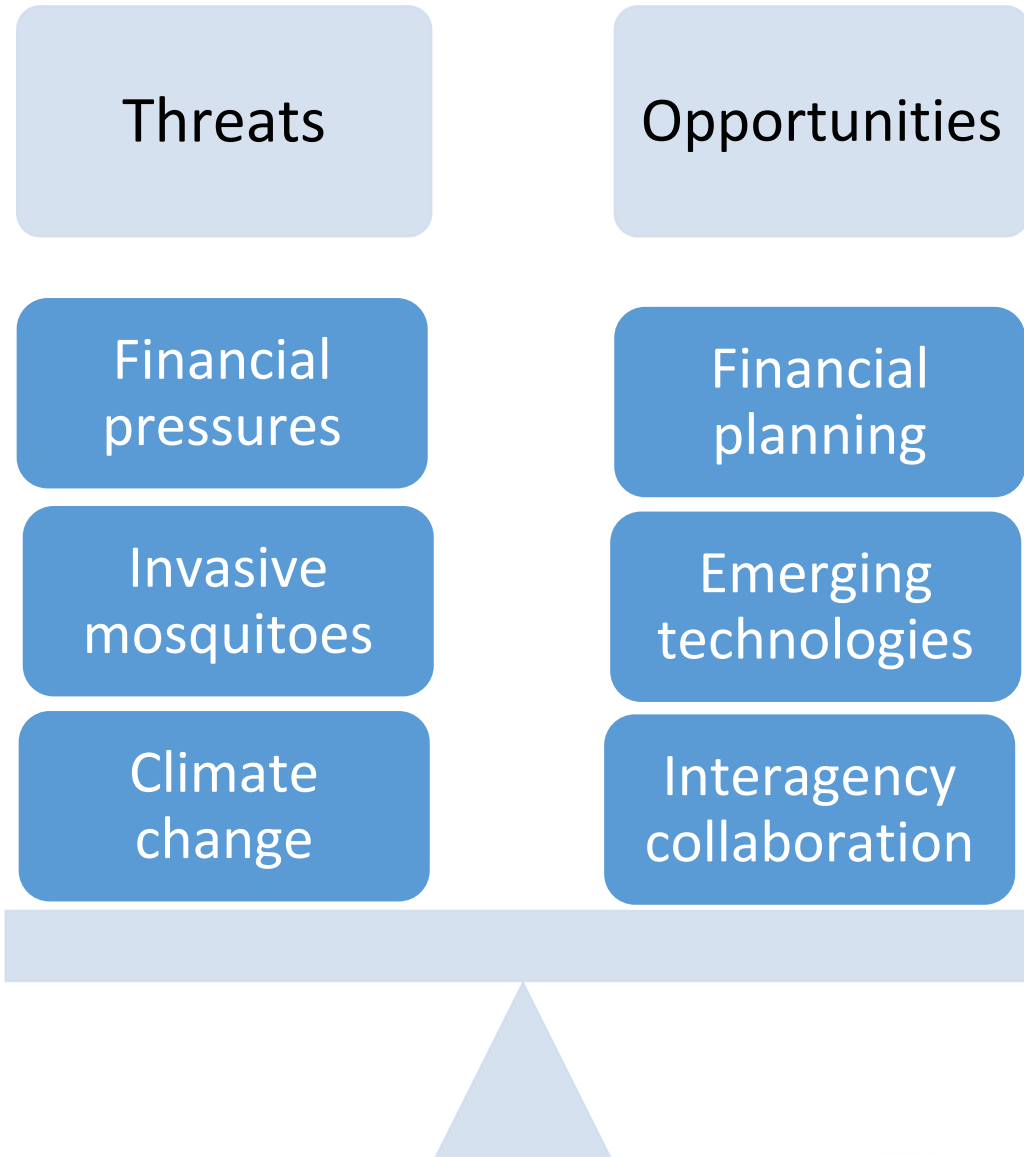

# 1. Financial Planning



\$2.50 benefit  
assessment *can* be  
raised to \$7.00 for  
enhanced services



Pension  
stabilization-115  
trust with PARS



Reserve funds with  
CAMP

## 2. Innovative Control Methods



Irradiate reproductive cells



Wolbachia-infect



Modify genome using Gene Drives  
(CRISPR)





# 3. Interagency collaboration: trash capture devices/ BMPs



California Stormwater  
Quality Association



# 4. Healthy Wetlands



California Department of  
Fish and Wildlife



**South Bay Salt Pond  
Restoration Project**



# 5. Emerging technologies: drone imagery of marshes where mosquitoes can breed

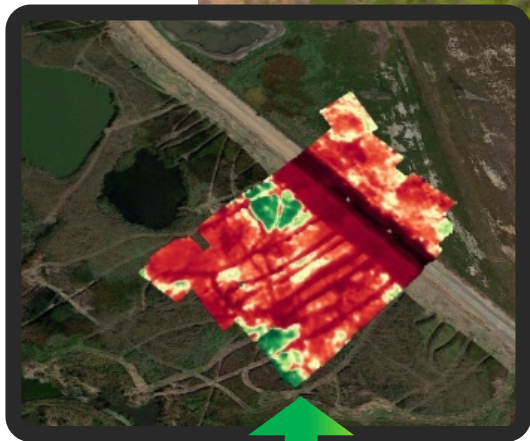

Multispectral camera imagery of landscape



# Partnerships



San Francisco Bay Restoration Authority



# Mosquito Sources in the City of Berkeley



- Unmaintained swimming pools, catch basins, street gutters, creeks: Codornices & at Rose Garden
- McLaughlin East shore State Park
- Flooded basements
- Fish ponds-  
mosquitofish requests
- Treeholes in Botanical Garden & John Hinkel Park
- UC Berkeley





- **Ryan Clausnitzer, MPA**
- **General Manager**
- 23187 Connecticut Street
- Hayward, CA 94545
- [www.mosquitoes.org](http://www.mosquitoes.org)
- [ryan@mosquitoes.org](mailto:ryan@mosquitoes.org)
- 510-925-1756

Thank you-







ORDINANCE NO. 7,645-N.S.

AMENDING BERKELEY MUNICIPAL CODE TITLE 12 TO ESTABLISH GENERAL REGULATIONS AND SPECIFIC OPERATING STANDARDS FOR CANNABIS BUSINESSES; ADDING CHAPTER 12.21, AMENDING CHAPTER 12.22, AND REPEALING CHAPTERS 12.23, 12.25, AND 12.27

BE IT ORDAINED by the Council of the City of Berkeley as follows:

Section 1. That Berkeley Municipal Code Chapter 12.21 is added to read as follows:

**Chapter 12.21  
CANNABIS BUSINESSES: GENERAL REGULATIONS**

**Sections:**

- 12.21.010 Purpose and Applicability**
- 12.21.020 Definitions**
- 12.21.030 Information Requirements**
- 12.21.040 Operating Standards**
- 12.21.050 Records**
- 12.21.060 Operating Procedure and Criteria**
- 12.21.070 Confidentiality of Information**
- 12.21.080 Authority of City Manager**
- 12.21.090 Abatement of Violations**
- 12.21.100 Fees**
- 12.21.110 Severability**

**12.21.010 Purpose and Applicability**

The purpose of this Chapter is to collect in one location in this Code all of the definitions and general operating standards applicable to Cannabis Businesses and to implement the provisions contained in the Medicinal and Adult-Use of Cannabis Regulation and Safety Act, codified in Division 10 of the Business and Professions Code, Section 1602 and 1617 of the Fish and Game Code, Sections 37104, 54036, and 81010 of the Food and Agriculture Code, Division 10 of the Health and Safety Code, Division 2 of the Revenue and Taxation Code, Sections 23222 and 2429.7 of the Vehicle Code, and Sections 1831, 1847, and 13276 of the Water Code ("MAUCRSA"), as amended from time to time.

**12.21.020 Definitions**

A. "Active Ingredients" means, in the case of dried cannabis flowers, extractions or infusions, delta-9- tetrahydrocannabinolic acid, delta-9-tetrahydrocannabinol,

cannabidiolic acid, cannabidiol, and any cannabinoid or propyl cannabinoid derivative when present in amounts greater than .5% by dry weight, and any mono- or sesquiterpenoid present in an amount exceeding .3% of a product's dry weight.

B. "Adult Use Cannabis" means Cannabis and Cannabis Products intended for consumption by adults 21 and over, and that is not Medicinal Cannabis.

C. "Adulterant" means any poisonous or deleterious substance that may render Cannabis or Cannabis Products impure or injurious to health, as determined by the City's Environmental Health or Public Health Divisions.

D. "Adulterated" means any Cannabis or Cannabis Product with Contaminates exceeding any testing thresholds and/or containing any Adulterant.

E. "Batch" shall have the same meaning as set forth in MAUCRSA, as amended from time to time,

F. "Cannabis" shall have the same meaning as set forth in Section 26001 of the Business and Professions Code, as amended from time to time, and includes both adult-use and medicinal cannabis.

G. "Cannabis Business" is a business possessing a State license as specified in Section 26050 of the Business and Professions Code, as amended from time to time, and includes Cannabis Businesses with an "A" designation ("ACB") and Cannabis Businesses with an "M" designation ("MCB").

H. "Cannabis By-Products" means delta-8-THC and cannabinol when present in amounts greater than 0.2% of a product's dry weight.

I. "Cannabis Compound(s)" means any or all of the following chemicals, as the context requires:

1. "THC" or " $\Delta^9$ -THC" means  $\Delta^9$ -tetrahydrocannabinol, ( $\Delta$ )-(6aR,10aR)-6,6,9-trimethyl-3-pentyl-6a,7,8,10a-tetrahydro-6H-benzo[c]chromen-1-ol.
2. "THCA" or " $\Delta^9$ -THCA" means the acid form of THC.
3. "CBD" or "Cannabidiol" means 2-[(1R,6R)-6-isopropenyl-3-methylcyclohex-2-en-1-yl]-5-pentylbenzene-1,3-diol.
4. "CBDA" or "Cannabidiolic acid" means the acid form of CBD.

5. "CBN" or "Cannabinol" means 6,6,9-trimethyl-3-pentyl-benzo[c]chromen-1-ol.

J. "Cannabis Cultivation Facility" or "Facility" shall have the same meaning as "cultivation site" as set forth in Section 26001 of the Businesses and Professions Code. It includes "Major Cannabis Cultivation Facility", defined as follows:

"Major Cannabis Cultivation Facility" means a Facility that is between 10,000 sf and 22,000 sf in total canopy area.

K. "Cannabis Products" shall have the same meaning as set forth in Section 26001 of the Business and Professions Code, as amended from time to time, and includes both medicinal and adult-use Concentrates and Cannabis Products.

L. "Cannabis Waste" means contaminated Cannabis or Cannabis Products that cannot be rendered safe and any Cannabis or Cannabis Products that have been designated as a waste by a Cannabis Business, or regulatory authority. Cannabis Waste does not include materials from the cultivation and manufacturing processes not known to be contaminated with pesticide or heavy metal residues and which may be composted by an approved process.

M. "Concentrate" shall have the same meaning as set forth in Section 26001 of the Business and Professions Code, as amended from time to time.

N. "Contaminant" means any pesticide, residual solvent or microbiological organism or product thereof, heavy metal, or any other Adulterant as determined by the Environmental Health Division.

O. "Cosmetic Cannabis Product" means any article, or its components, intended to be rubbed, poured, sprinkled, or sprayed on, introduced to, or otherwise applied to, the human body, or any part of the human body, that is not an Edible Cannabis product and includes tinctures.

P. "Cultivate" and "Cultivation" mean any activity involving the planting, growing, harvesting, drying, curing, grading or trimming of cannabis.

Q. "Cultivator" means an individual or entity required to be licensed to cultivate cannabis pursuant to MAUCRSA, as amended from time to time.

R. "Deliver" and "Delivery" shall mean any transit of Cannabis or Cannabis Product from a Retailer to a Customer at a residence.

S. "Delivery-Only Retailer" is a Retailer that is limited to acquiring Cannabis and

delivering it to its Qualified Patients, Primary Caregivers, and adult consumers, and does not have a location to which Qualified Patients, Primary Caregivers, and adult consumers may come to acquire Cannabis or any other good or service.

T. "Distributor" means an individual or entity required to be licensed as a distributor pursuant to MAUCRSA, as amended from time to time.

U. "Edible Cannabis Product" (or "Edible") means a cannabis product that is intended to be used, in whole or in part, for human consumption, including but not limited to, chewing gum, but excluding products set forth in Division 15 (commencing with Section 32501) of the Food and Agricultural Code. An edible cannabis product is not considered food, as defined by Section 109935 of the health and Safety Code, or a drug, as defined by Section 109925 of the Health and Safety Code.

V. "Manufacturer" means an individual or entity required to be licensed as a manufacturer pursuant to MAUCRSA, as amended from time to time.

W. "Medicinal Cannabis" means Cannabis and Cannabis Products intended as medicine for those with a valid physician's recommendation in compliance with California law.

X. "Microbusiness" shall have the same meaning set forth in MAUCRSA, as amended from time to time, and includes "Retail Nursery Microbusiness", defined as follows:

1. "Retail Nursery Microbusiness" is restricted to either a Class 1 or Class 2 Nursery that sells plants and seeds on a retail basis, either at a location to which Customers may come to acquire cannabis plants or seeds, or by delivering plants or seeds. No other cannabis products may be sold at this type of use. Distribution is limited to those products directly related to this business. No cannabis consumption is permitted on site.

Y. "Nursery" means an individual or entity required to be licensed as a Type 4 Cultivator pursuant to MAUCRSA, as amended from time to time, and includes "Class 1 Nursery" and "Class 2 Nursery," defined as follows:

1. "Class 1 Nursery" means a nursery that only produces immature plants, such as cuttings or clones.
2. "Class 2 Nursery" means a nursery that produces mature plants with flowers for the purpose of producing seeds, whether for distribution to a Retailer or for research purposes. A Class 2 Nursery may also produce cuttings or clones.

Z. "Primary Caregiver" shall have the same meaning as set forth in Section 26001 of the Business and Professions Code, as amended from time to time.

AA. "Principal" means any person that has direct or non-delegated indirect authority over the management or policies of a Cannabis Business.

BB. "Protected Health Information" means documentation of a an MCB's Qualified Patient's medical history or condition other than a physician's recommendation, an identification card issued pursuant to Health and Safety Code Section 11362.7 et seq., or the written designation of a Primary Caregiver by a Qualified Patient or identification card holder. Protected Health Information shall not include information conveyed by a Qualified Patient to a Retailer regarding such Qualified Patient's medical condition, information conveyed by a Qualified Patient to a Retailer regarding efforts to ameliorate or otherwise address symptoms associated with such Qualified Patient's medical condition, or information regarding Cannabis or Medicinal Cannabis Products provided to a Qualified Patient.

CC. "Qualified Patient" shall have the same meaning as provided in California Health and Safety Code Section 11362.7.

DD. Retailer

1. "Retailer" means both Retailers with a location to which Customers, Qualified Patients, or Primary Caregivers may come to acquire Cannabis or any other good or service, and Delivery-Only Retailers.

2. "Retailer" shall mean an ACB ("A-Retailer") or MCB ("M-Retailer") that is authorized under Chapter 12.22, Title 23, and California law to dispense Cannabis at a non-residential location. A Retailer may deliver to its Qualified Patients, Primary Caregivers, or adult consumers and provide other incidental services to its Qualified Patients, Primary Caregivers, or adult consumers to the extent permitted by California law.

EE. "Solvent" means any substance in which another substance is dissolved, forming a solution.

FF. "Tincture" means an extract of Cannabis or solution of such, typically made with food-grade alcohol or glycerin.

GG. "Temporary Cannabis Event" shall mean an activity required to be licensed as a temporary cannabis event pursuant to MAUCRSA, as amended from time to time. Such events may involve onsite sale and consumption of cannabis goods and must be operated by a state-licensed event organizer.

### **12.21.030 Information Requirements**

Every Cannabis Business shall provide the following information to the City's Environmental Health Division, and shall be updated whenever there is any material change.

- A. A description of the Cannabis Business and its location, which shall include such information as the City may require that demonstrates compliance with applicable provisions of this Chapter.
- B. The name, address and 24-hour contact information for each Principal, including a photocopy of at least one primary form of photo identification, such as a California Driver's License or US Passport. This information shall also include any aliases, maiden or married names or other former legal names.
- C. Proof of the nature of the Cannabis Business's organizational status, such as articles of incorporation, by-laws, partnership agreements, and other documentation as may be appropriate or required by the City.

### **12.21.040 Operating Standards**

- A. All Cannabis Businesses shall comply with the operating standards set forth in this Section.
- B. Cannabis Businesses shall comply with Health and Safety Code Sections 11362.7 et seq. and any other California laws that may be adopted concerning Adult-Use and Medicinal Cannabis, including but not limited to the Medicinal and Adult-use of Cannabis Regulation and Safety Act, and Chapters 12.22 or 12.26 and Title 23 of the Berkeley Municipal Code, and any other applicable City laws or regulations, and shall pay all applicable state or local taxes and fees. To the extent the requirements of this Chapter and Chapters 12.22 and 12.26 are more restrictive than California law, they shall apply. To the extent the requirements of this Chapter and Chapters 12.22 and 12.26 are less restrictive than California law, the requirements of California law shall apply except in instances where the state has expressly allowed localities to be less strict.
- C. MCBs may retain memberships.
- D. Cannabis Businesses shall only obtain Cannabis from licensed Distributors as authorized by California law.
- E. All employees and volunteers of a Cannabis Business must be at least 21 years of age.

F. The Environmental Health Division may require any Cannabis Business to submit an odor control plan to be approved by the Division.

G. Non-diversion. ACBs shall take all practicable steps necessary to prevent and deter diversion of Cannabis and Cannabis Products to persons under 21 years of age, including by using the state-mandated Track-and-Trace system. MCBs shall take all practicable steps necessary to prevent and deter diversion Medicinal Cannabis and Medicinal Cannabis Products to persons other than Qualified Patients or their Primary Caregivers, or non-MCBs, including by using the state-mandated Track-and-Trace system.

H. Security.

1. Cannabis Businesses shall provide adequate security and lighting on-site to ensure the safety of persons and protect the premises from theft at all times. Lighting shall be of sufficient intensity to illuminate all areas of the premises.
2. Retailers, Distributors and Cultivators must maintain camera coverage of their entire grounds to an extent sufficient to ensure the safety of persons and deter crime. Cameras must be maintained in good condition, and use a format approved by the City Manager, which is of adequate quality, color rendition and resolution to allow the ready identification of any individual committing a crime. The cameras shall be in use 24 hours per day, seven (7) days per week. The areas to be covered by the security cameras include, but are not limited to, dispensing areas, storage areas, cultivation areas, all doors, parking lots, and any other area determined by the City Manager. Surveillance footage must be retained for a period of 90 days and made available to the Berkeley Police Department for purposes of investigation of alleged crimes, promptly upon request without the necessity of a warrant or subpoena. Retention and maintenance of security camera recordings shall comply with Section 12.21.070. Retailers must also maintain security guards.
3. Cannabis Businesses must be equipped with an alarm system that is operated and monitored by a security company licensed by and in good standing with the California Department of Consumer Affairs. Alarms shall be maintained and in good working condition at all times.
4. In order to prevent unauthorized entry during non-business hours, Retailers, Distributors and Cultivators shall either secure all exterior windows and roof hatches from the inside with bars, retractable, folding or sliding metal gates, or metal rollup or accordion doors, or provide at least one security guard during those hours.

5. Any security guards employed by Cannabis Businesses shall be licensed and possess a valid Department of Consumer Affairs "Security Guard Card" at all times. Security personnel may not be armed.
6. All Cannabis Businesses must securely store all Cannabis at all times, except for limited amounts used for display purposes, samples or immediate sale, and the entrance to all storage areas shall be locked and under the control of staff at all times.
7. Cannabis Businesses shall make transactions with payment methods other than cash whenever feasible. All cash received, except that needed for retail customer transactions shall be kept in a secure receptacle such as a drop safe or other type of safe.
8. If any of the requirements in this section conflict with state law, the stricter requirement will apply.

I. Neighborhood compatibility

1. Cannabis Businesses shall be operated to ensure neighborhood compatibility, and shall take all steps necessary to ensure that Customers do not create neighborhood disturbances. Such measures shall include, but not be limited to, providing a security guard to patrol the area surrounding any Retailer, Distributor or Cultivator during all hours of operation.
2. Retailers shall provide the Police Department and all residents and property owners within 100 feet with the current name, phone number, secondary phone number and e-mail address of an on-site community relations staff person to whom notice of any operating problems associated with the establishment may be reported. This information shall be updated as necessary to keep it current. Retailers shall encourage neighbors to call this person to try to solve any operating problems.
3. All Cannabis Businesses shall have an on-site manager responsible for overall operation at all times they are open, and shall provide the Police Department with contact information for all such persons, including telephone number and e-mail address. Cannabis Businesses shall also provide the Police Department with the current name and phone numbers of at least one 24-hour-on-call manager. This information shall be updated as necessary to keep it current.
4. Cannabis Businesses shall take all reasonable steps to discourage and correct



objectionable conditions that constitute a public or private nuisance in parking areas, sidewalks, alleys and areas surrounding the premises and adjacent properties. Such conditions include, but are not limited to: smoking; creating a noise disturbance; loitering; littering; and graffiti.

5. Cannabis Businesses shall ensure all graffiti is removed from property and parking lots under their control within 72 hours of its appearance.

J. Sale and Consumption of Cannabis, Tobacco and Alcohol

1. Sale or consumption of tobacco is prohibited at Cannabis Businesses.
2. Sale and/or service of alcoholic beverages at Cannabis Businesses is prohibited.

K. Holding requirements. Any juice or beverage produced in accordance with Section 40270 of the California Code of Regulations Title 17, Division 1, Chapter 13, Subchapter 3, Article 4 that requires refrigeration to prevent the rapid growth of undesirable organisms or the formation of alcohol through fermentation shall be held below 41 Fahrenheit to prevent the cannabis product from becoming adulterated during the manufacturing, processing, packing, holding, and transporting. Transporting includes both by a Distributor among licensees and by Retailers conducting delivery to Customers, Qualified Patients, and Qualified Caregivers. Fixed facilities shall hold such cannabis products in equipment certified to ASTM commercial food safety equipment standards by an organization such as but not limited to NSF, UL, or ETL.

**12.21.050 Records**

A. General. All Cannabis Businesses shall maintain contemporaneous financial and operational records sufficient to show compliance with this Chapter, Chapter 12.26, and applicable California law, as well as satisfaction of commitments made in the Cannabis Business's application and during the ranking and allocation process. Such records shall be maintained in a secure location under the control of the Cannabis Business within the City of Berkeley, and shall be subject to inspection by the City upon reasonable notice during regular operational hours or by appointment.

B. Finances.

1. Cannabis Businesses shall make their financial records available to the City on an annual basis. Such audited records shall be limited to information necessary for the City to determine fair payment of taxes and for M-Retailers very low income 2% distribution verification.

C. Operations. Cannabis Businesses shall maintain the following information and make

it available to the City within 30 days of the end of each calendar year.

1. The total number of very low-income members and the amount distributed;
2. The total and net amount of revenue collected during the year;
3. The consideration paid for each Batch;
4. Monetary and non-monetary contributions;
5. Total monetary and non-monetary distributions to suppliers;
6. Salaries and overhead; and
7. A complete list of the types of Cannabis, Cannabis Products and Edibles available, and the prices thereof.

#### **12.21.060 Operating Procedure and Criteria**

No Cannabis Business may operate in the City of Berkeley without all applicable City of Berkeley licenses. The Council may by resolution establish procedures and criteria for accepting applications to operate Cannabis Businesses and determining which, if any, to approve.

#### **12.21.070 Confidentiality of Information**

A. The City's review of information submitted or maintained pursuant to this Chapter shall preserve the confidentiality of all information about Principals and members to the maximum extent consistent with state and local law. The City shall incur no liability for the inadvertent or negligent disclosure of such information. Disclosure of any Principal or Member information to the City for purposes of this Chapter shall not be deemed a waiver of confidentiality. Financial information provided to the City pursuant to Section 12.21.050 shall be deemed to be "financial information" covered by Chapter 7.26.

B. The information required by Section 12.21.040 and recordings from security cameras, shall be confidential and shall not be subject to public inspection or disclosure except to City and State employees for purposes of law enforcement.

#### **12.21.080 Authority of City Manager**

A. The City Manager or his or her designee shall have authority to determine the nature of any Cannabis Business or purported Cannabis Business and whether that entity complies with any of the requirements of this Chapter, Chapters 12.22 and 12.26, and

Title 23, and to conduct inspections as provided in Chapter 1.16.

B. The City Manager or his or her designee may promulgate regulations for the administration and implementation of this Chapter, including, but not limited to, regulations relating to non-diversion, record-keeping, and tracking and tracing Cannabis.

C. The City Manager or his or her designee may require any Cannabis Business to obtain operating permits from the City of Berkeley Fire Department, Toxics Management Division, Environmental Health Division, and any other department or division.

D. The City Manager or his or her designee shall have authority to enter onto private property and perform such inspections as may be necessary or convenient to implement and enforce this Chapter, Chapters 12.22 and 12.26, and Title 23, and to adopt regulations to implement this Chapter, Chapters 12.22 and 12.26, and Title 23.

#### **12.21.090 Abatement of Violations**

A. Violations of this Chapter or Chapters 12.22 or 12.26 shall constitute an administrative citation under Chapter 1.26. The City may enforce this Chapter through proceedings under Chapter 1.24, Chapter 1.28, Chapter 23B.64 and any other law or ordinances it deems appropriate.

B. Notwithstanding anything to the contrary, violations of this Chapter or Chapters 12.22 or 12.26 shall not be punishable as public offenses to the extent that doing so would conflict with California law.

#### **12.21.100 Fees**

The City Council may establish by resolution the fees that shall be charged to Cannabis Businesses for administration and implementation of this Chapter. The adoption of such fees shall not prevent the City from recovering enforcement costs from Cannabis Businesses not specified in such resolution.

#### **12.21.110 Severability**

If any word, phrase, sentence, part, section, subsection, or other portion of this Chapter, or any application thereof to any person or circumstance is declared void, unconstitutional, or invalid for any reason, then such word, phrase, sentence, part, section, subsection, or other portion, or the prescribed application thereof, shall be severable, and the remaining provisions of this Chapter, and all applications thereof, not having been declared void, unconstitutional or invalid, shall remain in full force and effect. The City Council hereby declares that it would have passed this title, and each section, subsection, sentence, clause and phrase thereof, irrespective of the fact that any one or

more sections, subsections, sentences, clauses or phrases had been declared invalid or unconstitutional.

Section 2. That Berkeley Municipal Code Chapter 12.22 is amended to read as follows:

**Chapter 12.22  
CANNABIS BUSINESS OPERATING STANDARDS**

**Sections:**

Article I General

**12.22.010 Applicability and Purpose**

**12.22.020 Selection Process**

Article II Cannabis Businesses

**12.22.030 Eligibility Requirements**

**12.22.040 Retailers**

**12.22.050 Distributors**

**12.22.060 Manufacturers**

**12.22.070 Cultivators**

**12.22.080 Testing Laboratories**

**12.22.090 Microbusinesses**

**12.22.100 Temporary Cannabis Events**

**12.22.110 Collectives Prohibited**

Article III Enforcement

**12.22.120 Fees**

**12.22.130 Authority of City Manager**

**12.22.140 Severability**

**12.22.150 Reserved**

**12.22.160 Reserved**

**12.22.170 Reserved**

**12.22.180 Reserved**

**12.22.010 Applicability and Purpose**

A. This Chapter applies to all Cannabis Businesses as defined in Chapter 12.21. The purpose of the Chapter is to provide specific operating standards applicable to these businesses and to implement the provisions contained in the Medicinal and Adult-Use of Cannabis Regulation and Safety Act, codified in Division 10 of the Business and Professions Code, Section 1602 and 1617 of the Fish and Game Code, Sections 37104, 54036, and 81010 of the Food and Agriculture Code, Division 10 of the Health and Safety Code, Division 2 of the Revenue and Taxation Code, Sections 23222 and 2429.7 of the

Vehicle Code, and Sections 1831, 1847, and 13276 of the Water Code (“MAUCRSA”), as amended from time to time.

#### **12.22.020 Selection Process**

The Council may by resolution establish procedures and criteria for accepting applications to operate Retailers or Major Cannabis Cultivators and determining which, if any, to approve.

#### **12.22.030 Eligibility requirements**

A. No Principal of any business of a certain license type may be a Principal for any other business of the same license type in the City of Berkeley, except that a State “M” licensee may also be a State “A” licensee of the same license type.

#### **12.22.040 Retailers**

Retailers shall comply with the operating standards set forth in this Section.

A. Retailers must obtain operating permits from and allow inspections by the City of Berkeley Environmental Health Division.

B. Retailers shall only allow Customer visits between the hours of 9:00 a.m. and 9:00 p.m.

C. A Retailer may deliver cannabis only to the extent allowed by its State license.

D. Accessibility. Retailers shall comply with all physical accessibility requirements that would be applicable to a newly-constructed building, except that pre-existing Retailers permitted under Ordinance No. 6826-N.S. shall not be required to comply with such requirements as long as they remain in the same location as when this Chapter became effective, except as may be required by other laws.

E. Signage.

1. All Retailers must either provide to each Customer or prominently display at all points of sale a notice containing the language set forth in this Section.

a. If provided to each Customer, the notice shall be printed on paper that is no less than 5 inches by 8 inches in size, and shall be printed in no smaller than 18-point font.

b. If prominently displayed at all points of sale, the notice shall be printed on a poster no less than 3 feet by 3 feet in size, shall be printed in no smaller than

a 28-point font, displayed prominently behind the main dispensing counter at eye-level (i.e., with mid-point five feet above the floor).

2. All Retailers must prominently display a notice as set forth in subsection 12.22.040.E that contains the following language:

“The use of cannabis may impair a person’s ability to drive a motor vehicle or operate heavy machinery.”

All Retailers that provide delivery services, including Delivery-only Retailers, must provide this notice to each delivery Customer as set forth in subsection 12.22.040.E.

3. All Retailers must prominently display a notice as set forth in subsection 12.22.040.E that contains the following language:

“WARNING: Cannabis is not tested by local, state or federal governmental agencies for health, safety, or efficacy. There may be health risks associated with the consumption of cannabis or cannabis products.”

All Retailers that provide delivery services, including Delivery-only Retailers, must provide this notice to each Customer as set forth in subsection 12.22.040.E.

4. Any M-Retailer that allows Customer visits must prominently display a notice as set forth in subsection 12.22.040.E that contains the following language::

“This M-Retailer provides medicinal cannabis only to Qualified Patients and their Primary Caregivers, who must have a valid California Medical Marijuana Identification Card or a verifiable, written recommendation from a physician for medicinal cannabis.”

All M-Retailers that provide delivery services, including Delivery-only M-Retailers, must provide this notice to each delivery Customer as set forth in subsection 12.22.040.E.

5. All M-Retailers must prominently display a notice as set forth in subsection 12.22.040.E that contains the following language:

“This Medicinal Cannabis Retailer is licensed in accordance with the laws of the City of Berkeley and the State of California. The sale or diversion of medicinal cannabis for non-medical purposes is a violation of State and local laws.”

All M-Retailers that provide delivery services, including Delivery-only M-Retailers, must provide this notice to each delivery Customer as set forth in subsection 12.22.040.E.

6. Any A-Retailer that allows Customer visits must prominently display a notice as set forth in subsection 12.22.040.E that contains the following language:

“This Adult-Use Cannabis Retailer is licensed in accordance with the laws of the City of Berkeley and the State of California. The sale or diversion of adult- use cannabis to persons under the age of 21 is a violation of State and local laws.”

All A-Retailers that provide delivery services, including Delivery-only A-Retailers, must provide this notice to each delivery Customer as set forth in subsection 12.22.040.E.

#### F. Consumption of Cannabis

1. The consumption of Cannabis or Cannabis Products in public places is prohibited.

#### G. Delivery Requirements

1. Medicinal and Adult Use cannabis may be delivered by a Retailer, as long as the deliveries comply with the appropriate State license.

2. All Retailers that provide delivery services must comply with the following requirements.

a. All vehicles used for delivery shall be maintained and operated in a manner and in a condition required by law and applicable regulations.

b. The following persons may not drive delivery vehicles:

i. a person who does not possess a valid driver’s license;

ii. a person who has been at fault within the immediately preceding two years in any motor vehicle accident causing death or personal injury;

iii. a person who has been at fault in three or more motor vehicle accidents within the previous 12 months;

iv. a person who has been under suspension, revocation or probation within the last five years by the Department of Motor Vehicles for a cause involving the safe operation of a motor vehicle;

- v. a person who has been convicted of any of the following misdemeanor offenses within the past five years: driving under the influence or reckless driving involving alcohol or reckless driving involving bodily injury;
  - vi. a person who has been convicted of any of the following offenses: a second or subsequent conviction for driving under the influence, or any felony conviction for driving under the influence (with or without injury), or vehicular manslaughter, or habitual traffic offender.
- c. The following persons may not be involved in making deliveries:
- i. any person who is required to register as a sex offender under Section 290 of the California Penal Code;
  - ii. any person who has within the past ten years been convicted of any felony offense involving moral turpitude.
- d. Persons involved in making deliveries must have in their possession a copy of the document memorializing the City's approval of the delivery service.
- e. Persons involved in making deliveries may not be armed.
- f. Delivery vehicles may not advertise any activity related to Cannabis, carry symbols or emblems related to Cannabis, or advertise the name of the Retailer.
- g. Delivery of Cannabis shall be directly to the residence of the Customer unless said residence is in a park, school or hospital. Deliveries to parks, schools, hospitals, and all non-residential locations are prohibited.
- h. Deliveries may occur only between the hours of 8:00 a.m. and 10:00 p.m.
- i. Delivery vehicles shall not carry or transport at any one time an amount of Cannabis, Cannabis Products, cash and/or cash equivalents worth, in total, more than three thousand dollars (\$3,000).
- j. A manifest must be created for each delivery or series of deliveries prior to departure from the Retailer or Delivery-Only Retailer, and the employee may not make any unnecessary stops between deliveries or deviate



substantially from the manifest route, unless a stop is necessary for personal safety.

k. All orders to be delivered shall be packaged at the Retailer or Delivery-only Retailer by the name or identification number of the Customer for whom the delivery is intended.

l. The person responsible for making deliveries shall have a copy of the record of all delivery requests while making deliveries.

m. All Retailers that provide delivery service shall maintain at all times Commercial General Liability insurance providing coverage at least as broad as ISO CGL Form 00 01 on an occurrence basis for bodily injury, including death, of one or more persons, property damage and personal injury with limits of not less than One Million Dollars (\$1,000,000) per occurrence and Comprehensive Automobile Liability (owned, non-owned, hired) providing coverage at least as broad as ISO Form CA 00 01 on an occurrence basis for bodily injury, including death, of one or more persons, property damage and personal injury, with limits of not less than One Million Dollars (\$1,000,000). The Commercial General Liability policy shall provide contractual liability, shall include a severability of interest or equivalent wording, shall specify that insurance coverage afforded to the City shall be primary, and shall name the City, its officials and employees as additional insured. Failure to maintain insurance as required herein at all times shall be grounds for immediate suspension of the privilege of providing delivery service.

#### H. M-Retailers

1. M-Retailers must not admit any person without first verifying his or her status as a Qualified Patient or Primary Caregiver.
2. No physician recommendations for Medicinal Cannabis may be provided on site.
3. M-Retailers may not provide more Medicinal Cannabis to a Qualified Patient or Primary Caregiver than is necessary for the personal medicinal use of the Qualified Patient for whom the Medicinal Cannabis is intended, and may not dispense more Medicinal Cannabis to a Qualified Patient or Primary Caregiver per day than permitted by State law.

4. M-Retailers must take all practicable steps necessary to prevent and deter diversion of Medicinal Cannabis to any person who is not a Qualified Patient or Primary Caregiver. M-Retailers must limit access to Medicinal Cannabis to authorized personnel only. M-Retailers must maintain an inventory management system that accounts for all Medicinal Cannabis separately from Adult Use Cannabis if both types are sold or distributed at the Retailer.
5. M-Retailers must not admit any Qualified Patient under 18 years of age pursuant to MAUCRSA.
6. Medicinal Cannabis for low income persons
  - a. At least 2% (by weight) of the annual amount of Medicinal Cannabis in dried plant form provided by a M-Retailer to Qualified Patients and Primary Caregivers shall be provided at no cost to very low-income Qualified Patients who are Berkeley residents or their Primary Caregivers. This amount shall be calculated every six months, based on the amount dispensed during the immediately preceding six months. Medicinal Cannabis provided under this Section shall be the same quality on average as Medicinal Cannabis that is dispensed to other persons.
  - b. For purposes of this Section, income shall be verified using federal income tax returns or another reliable method approved by the City Manager.
  - c. For purposes this Section, "very low income" shall mean the household income levels established by the U.S. Department of Housing and Urban Development.
  - d. M-Retailers shall keep an accurate roster of very low-income Qualified Patients who are Berkeley residents, which shall include a copy of either a California Medical Cannabis Identification Card or a physician's recommendation, and, if using a Primary Caregiver, a written authorization from the Qualified Patient to be represented by such Primary Caregiver. Such records shall be maintained in a manner that protects the confidentiality of the Qualified Patient and Primary Caregiver.
  - e. M-Retailers shall track distributions to very low-income Qualified Patients (or their Primary Caregivers) in an inventory management system compatible with the state Track-and-Trace program. M-Retailers shall generate a report every six (6) months showing the total percentage of Medicinal Cannabis sales

distributed to Berkeley residents. If an M-Retailer voluntarily expands the program to residents outside of Berkeley, that percentage shall be calculated separately.

I. A-Retailers must not admit any person under 21 years of age. If an A-Retailer also holds an M-Retailer license, access to the M-Retailer portion of the establishment is subject to the requirements of subsection 12.22.040.H.

### **12.22.050 Distributors**

A. Distributors must obtain operating permits from and are subject to inspections by the City of Berkeley Environmental Health Division.

B. Distributors must maintain a written or computerized log compatible with the State Track-and-Trace system documenting:

1. the date, type, and amount of Product tested;
2. the source(s) of any contaminated Cannabis
3. the results of the testing, including the name and level of the substance detected; and
4. the disposition of the Cannabis from which any contaminated sample was obtained, including the amount and the date and manner of disposition.

Such logs shall be maintained for at least one year and be made available to the City upon request.

C. Distributors are subject to the provisions of the California Retail Food Code and the Sherman Food, Drug and Cosmetic Law, even if those laws are not directly applicable to Edible or Cosmetic Cannabis Products. Handwashing facilities shall be adequate and convenient and be furnished with running water at a suitable temperature. Handwashing facilities shall be located in preparation areas and where good sanitary practices require employees to wash and/or sanitize their hands, and provide effective hand-cleaning and sanitizing preparations and sanitary towel service or suitable drying devices.

D. Scales and weighing mechanisms must be able to weigh to within 1/100th of a gram, shall be maintained in good working order and shall be subject to annual inspection by

either the Alameda County Department of Agriculture/Weights and Measures or a licensed scale company.

### **12.22.060 Manufacturers**

A. All Manufacturers must obtain operating permits from and are subject to inspections by the City of Berkeley Environmental Health Division.

B. Compliance with State Food and Product Safety Requirements.

1. A Manufacturer that prepares Cannabis Products must comply with the relevant provisions of all State and local laws regarding the preparation, distribution, labeling and sale of food and cosmetics, even if those laws are not directly applicable to Edible or Cosmetic Cannabis Products.

2. Preparation of Edible and Cosmetic Cannabis Products.

a. Individuals involved in the production or distribution of Edibles and Cosmetic Cannabis Products shall thoroughly wash their hands before commencing production and before handling the finished product. Gloves must be worn when packaging Edibles or Cosmetic Cannabis Products.

b. In order to reduce the likelihood of foodborne disease transmission, individuals who are suffering from symptoms associated with acute gastrointestinal illness or are known to be infected with a communicable disease that is transmissible through foodstuffs are prohibited from preparing Edibles or Cosmetic Cannabis Products until they are free of that illness or disease, or are incapable of transmitting the illness or disease through foodstuffs. Individuals who have sores or cuts on their hands must use gloves when preparing and handling Edibles or Cosmetic Cannabis Products.

c. All employees of Manufacturers who produce Edibles must be State certified food handlers. The valid certificate number of such Manufacturers must be on record at each Retailer where the edible product is distributed, and a copy of the certificate kept either on-site, or made available during inspections if kept off-site.

3. Scales and weighing mechanisms must be able to weigh to within 1/100th of a gram, shall be maintained in good working order and shall be subject to annual

inspection by either the Alameda County Department of Agriculture/Weights and Measures or a licensed scale company.

#### 4. Manufacture of Concentrates

- a. Cold-water and mechanical extraction equipment shall be maintained in sanitary condition and approved for use by the City of Berkeley Environmental Health Division.
- b. Any manufacture method using compressed gases or flammable solvents, whether volatile or non-volatile, shall be approved in advance and inspected by the City of Berkeley Fire Department and Toxics Management Division.
- c. All Concentrates shall be produced under sanitary conditions and maintained free of filth and contaminants.

### **12.22.070 Cultivators**

- A. Cultivators must obtain operating permits from and are subject to inspections by the City of Berkeley Environmental Health Division.
- B. Cultivator license types shall be the same as defined in MAUCRSA, with the exception of Nursery, as defined in Section 12.21.020.
- C. Energy Use. Cultivators must include all feasible (under the current Title 24, Part 6) cost-effective water and energy efficiency measures, including but not limited to natural daylighting, high efficiency lighting, networked lighting and mechanical controls, and natural cooling.
  1. Cultivators must include the following systems to the extent feasible: on-site renewable energy generation; energy storage batteries; water collection, filtration and reuse; and rainwater harvesting.
  2. Cultivators must include in any application for a Cannabis Cultivation Facility a description of all energy and water systems, measures employed to maximize efficient resource use, and the following metrics, with supporting documentation:
    - a. Planned lighting power density (watts/sf)
    - b. Planned lighting Energy Utilization Index (kBtu/sf/year)
    - c. Planned total site Energy Utilization Index (kBtu/sf/year)

d. Planned potable water consumption (gallons/sf/year)

3. Cultivators must mitigate the carbon dioxide emissions caused by the generation of electrical energy delivered to its Facility by participating in East Bay Community Energy's (EBCE) 100% renewable content option for electricity or equivalent. Until businesses have the option to purchase power through EBCE, the offset will be achieved through purchase of renewable energy certificates certified by the Center for Resource Solutions.

4. Cultivators shall be responsible for demonstrating compliance with this Section on a calendar-year basis. Documentation shall include copies of energy and water bills, as well as an authorization to energy and water providers to disclose energy and water consumption at the Facility directly to the City. All parties that are responsible for energy and water bills shall also be responsible for providing such documentation and authorization.

5. The annual amount paid by a Cultivator to both mitigate carbon dioxide emissions caused by the generation of electrical energy to its Facility and to offset the carbon content of all electrical energy delivered to its Facility shall not exceed 10% of the Facility's annual energy bill. This fee shall be reconsidered after five years to determine whether it should be readjusted to reflect lower energy rates or higher costs of renewable energy certificates.

D. Class 2 Nurseries must track the amount of, and disposition of, flower remaining after seed harvesting.

E. Cultivators must store in a safe manner all pesticides approved for use. Only pesticides approved for use may be stored onsite. Any unapproved pesticides found onsite may trigger a crop hold until the live plants are tested and found free of unapproved pesticide. Plants with any level of unapproved pesticides may be destroyed in the presence of City officials designated by the City Manager.

F. Cultivators must maintain all growing rooms in a clean, safe and sanitary manner and free of visible molds and fungal growth.

G. Cannabis Cultivation Facilities shall not harbor infestations of rodents or non-beneficial insects.

H. In Facilities using CO2 enrichment, ambient oxygen sensors shall be installed in any hallways, offices, or other enclosed occupied spaces.

### **12.22.080 Testing Laboratories**

Testing Laboratories must obtain operating permits from and are subject to inspections by the City of Berkeley Environmental Health Division.

### **12.22.090 Microbusinesses**

A. Microbusinesses must obtain separate City-issued operating permits for each activity conducted on the premises.

B. Microbusinesses are subject to the operating standards set forth in this Chapter for each activity conducted on the premises.

C. If the operating standards for the activities are different, the more restrictive standard shall apply, except as follows:

1. Signage for Retail Nursery Microbusinesses shall be subject to the regulations for storefront Retailers.

D. If the operating permit for one of the activities is revoked, the entire Microbusiness must cease operation until all operating permits at the premises are reinstated.

### **12.22.100 Reserved**

### **12.22.110 Collectives Prohibited**

Collectives previously authorized by the California Health and Safety Code shall be prohibited and must cease operation after January 9, 2019 pursuant to California Health and Safety Code Sections 11362.765 and 11362.775 and California Business and Professions Code Section 26033.

### **12.22.120 Fees.**

The City Council may establish by resolution the fees that shall be charged for administration and implementation of this Chapter. The adoption of such fees shall not prevent the City from recovering enforcement costs not specified in such resolution.

### **12.22.130 Authority of City Manager**

A. The City Manager or his or her designee shall have authority to determine the nature of any Cannabis Business or purported Cannabis Business and whether that entity

complies with any of the requirements of this Chapter, Chapters 12.21 and 12.26, and Title 23, and to conduct inspections as provided in Chapter 1.16.

B. The City Manager or his or her designee may promulgate regulations for the administration and implementation of this Chapter, including, but not limited to, regulations relating to non-diversion, record-keeping, and tracking and tracing Cannabis.

C. The City Manager or his or her designee may require any Cannabis Business to obtain operating permits from the City of Berkeley Fire Department, Toxics Management Division, Environmental Health Division, or any other department or division.

D. The City Manager or his or her designee shall have authority to enter onto private property and perform such inspections as may be necessary or convenient to implement and enforce this Chapter, Chapters 12.21 and 12.26, and Title 23, and to adopt regulations to implement this Chapter, Chapters 12.21 and 12.26, and Title 23.

E. The City Manager or his or her designee may promulgate regulations for the selection of Retailers, Cultivators, and other Cannabis Businesses that require a selection process.

#### **12.22.140 Severability**

If any word, phrase, sentence, part, section, subsection, or other portion of this Chapter, or any application thereof to any person or circumstance is declared void, unconstitutional, or invalid for any reason, then such word, phrase, sentence, part, section, subsection, or other portion, or the prescribed application thereof, shall be severable, and the remaining provisions of this Chapter, and all applications thereof, not having been declared void, unconstitutional or invalid, shall remain in full force and effect. The City Council hereby declares that it would have passed this title, and each section, subsection, sentence, clause and phrase thereof, irrespective of the fact that any one or more sections, subsections, sentences, clauses or phrases had been declared invalid or unconstitutional.



**12.22.150 Reserved**

**12.22.160 Reserved**

**12.22.170 Reserved**

**12.22.180 Reserved**

Section 3. That Berkeley Municipal Code Chapter 12.23 is repealed.

Section 4. That Berkeley Municipal Code Chapter 12.25 is repealed.

Section 5. That Berkeley Municipal Code Chapter 12.27 is repealed.

Section 6: Copies of this Ordinance shall be posted for two days prior to adoption in the display case located near the walkway in front of Old Berkeley City Hall, 2134 Martin Luther King Jr. Way. Within 15 days of adoption, copies of this Ordinance shall be filed at each branch of the Berkeley Public Library and the title shall be published in a newspaper of general circulation.

At a regular meeting of the Council of the City of Berkeley held on April 2, 2019, this Ordinance was passed to print and ordered published by posting by the following vote:

Ayes: Bartlett, Davila, Hahn, Harrison, Kesarwani, Robinson, Wengraf, and Arreguin.

Noes: None.

Absent: Droste.

ORDINANCE NO. 7,646-N.S.

ADDING BERKELEY MUNICIPAL CODE CHAPTER 20.40 TO ESTABLISH CANNABIS BUSINESS SIGNS AND CANNABIS PRODUCT ADVERTISING REGULATIONS

BE IT ORDAINED by the Council of the City of Berkeley as follows:

Section 1. That Berkeley Municipal Code Chapter 20.40 is added to read as follows:

**Chapter 20.40  
CANNABIS BUSINESS SIGNS AND CANNABIS  
PRODUCT ADVERTISING**

**Sections:**

- 20.40.010 Purpose.**
- 20.40.020 Definitions.**
- 20.40.030 Cannabis product advertising prohibited.**
- 20.40.040 Exceptions.**
- 20.40.050 Violations deemed a public nuisance.**
- 20.40.060 Enforcement.**
- 20.40.070 Reinspection fee.**
- 20.40.080 Exemptions.**
- 20.40.090 Joint and several liability.**
- 20.40.100 Severability.**
- 20.40.110 Permitted signs.**
- 20.40.120 Number of signs permitted on premises.**
- 20.40.130 Sign area limitations.**

**20.40.010 Purpose.**

The purposes of this chapter are to:

- A. To promote the general welfare and reduce illegal purchase and consumption of cannabis or cannabis products by persons under the age of 21, which is accomplished by limiting the exposure of persons under the age of 21 to cannabis product advertising; and
- B. To provide design criteria and development standards to be used in the review of applications for cannabis business signage to ensure that the cannabis

businesses are compatible with the other land uses in the City.

**20.40.020 Definitions.**

“Cannabis” and “Cannabis Products” shall have the same meaning as set forth in Berkeley Municipal Code Section 12.21.020.

"Cannabis product advertising" means any billboard, sign, poster, placard, device, graphic display, or other item which promotes or is designed to promote the sale, use or consumption of a particular brand of cannabis or cannabis products, but shall not mean any advertising on the packaging of the product itself.

"Owner or operator" includes the owner of the property at which the advertising subject to this chapter is located, the owner of any billboard or other structure on which cannabis product advertising is located, as well as the operator of any commercial or other establishment at that location.

"Person" means any individual, firm corporation, partnership, cooperative association, receiver, trustee, assignee public or private entity, or other legal entity.

"Publicly visible location" means any outdoor location and any window of a commercial establishment that is visible to the public from any street sidewalk, or other public thoroughfare. This shall not be construed to include the inside of any commercial establishment, with the exception of its windows.

**20.40.030 Cannabis product advertising prohibited.**

No person shall place or maintain, or cause or allow to be placed or maintained any cannabis product advertising in any publicly visible location, except as provided in this Chapter.

**20.40.040 Exceptions.**

This chapter shall not apply to cannabis product advertising which is:

- A. Inside any commercial establishment, except that no cannabis product advertising may be placed in a publicly visible location inside any commercial

establishment.

**20.40.050 Violations deemed a public nuisance.**

Any violation of the provisions of this chapter is declared to be a public nuisance. The procedures for the abatement of such nuisances shall be governed by Berkeley Municipal Code Chapter 1.24 as may hereafter be amended.

**20.40.060 Enforcement.**

A. Infraction. Any person violating any provision or failing to comply with any requirement of this chapter shall be deemed guilty of an infraction as set forth in Chapter 1.20 of this code.

1. Each separate display of cannabis product advertising in violation of this chapter is deemed to be a separate offense.
2. Each day an item of cannabis product advertising remains in violation of this chapter is deemed to be a separate offense.

B. Civil Action. In addition to any other remedy provided by this chapter, any violation of this chapter may be enforced by a civil action brought by the City or any other interested person. The City or any other interested person may seek and the court shall grant as appropriate:

1. Injunctive relief, both temporary and permanent;
2. Reasonable attorney fees and costs of suit.

C. Remedies Not Exclusive. Nothing in this chapter shall preclude the City from seeking any other remedy provided by law.

**20.40.070 Reinspection fee.**

The City Council may adopt a resolution establishing a fee which must be paid by the owner or operator of a specified location whenever the City Manager, or his or her designee, determines upon reinspection that a person has failed to comply with any orders, notices or directions issued by the City under this chapter.

**20.40.080 Exemptions.**

This chapter shall apply to all existing cannabis product advertising in violation of this chapter unless the owners or operators of the location at which such advertising is located provide written documentation to the City Manager, or his or her designee, within thirty days from the effective date of the ordinance codified in this chapter that this chapter unreasonably interferes with any contracts executed before the date of adoption of said ordinance.

A. Failure to provide such timely, written documentation shall be deemed a waiver of the right to seek an exemption.

B. The City Manager is authorized to grant an exemption from enforcement of this chapter for up to 6 months from the date of adoption. The decision of the City Manager with respect to such exemption is final.)

**20.40.090 Joint and several liability.**

The advertiser, the property owner and any operator of any location at which prohibited cannabis product advertising exists shall be jointly and severally liable for violations of this chapter.

**20.40.100 Severability.**

If any word, phrase, sentence, part, section, subsection, or other portion of this Chapter, or any application thereof to any person or circumstance is declared void, unconstitutional, or invalid for any reason, then such word, phrase, sentence, part, section, subsection, or other portion, or the prescribed application thereof, shall be severable, and the remaining provisions of this Chapter, and all applications thereof, not having been declared void, unconstitutional or invalid, shall remain in full force and effect. The City Council hereby declares that it would have passed this title, and each section, subsection, sentence, clause and phrase thereof, irrespective of the fact that any one or more sections, subsections, sentences, clauses or phrases had been declared invalid or unconstitutional.

**20.40.110 Permitted signs.**

A. Retailers that have a storefront and allow customer visits are allowed on-premises signs as set forth in BMC Chapter 20.24.

B. Delivery-only Retailers are allowed business complex signs as set forth in BMC

Section 20.16.070.

C. Non-retailers are allowed on-premises signs as set forth in BMC Chapter 20.32.

**20.40.120 Number of signs permitted on premises.**

- A. The number of on-premises signs for Cannabis Retailers are limited to BMC Section 20.24.030.
- B. The number of on-premises signs for Cannabis non-retailers are limited to BMC Section 20.32.030.

**20.40.130 Sign area limitations.**

- A. The sign area for all signs of Retailers that have a storefront shall not exceed seven and a half (7.5) percent of the building face of the premises or seventy-five (75) square feet, whichever is less.
- B. The sign area for all signs of Delivery only Retailers are subject to BMC Section 20.16.070.
- C. The sign area for all signs of non-Retailers shall not exceed twelve (12) square feet.

Section 2. Copies of this Ordinance shall be posted for two days prior to adoption in the display case located near the walkway in front of Old Berkeley City Hall, 2134 Martin Luther King Jr. Way. Within 15 days of adoption, copies of this Ordinance shall be filed at each branch of the Berkeley Public Library and the title shall be published in a newspaper of general circulation.

At a regular meeting of the Council of the City of Berkeley held on April 2, 2019, this Ordinance was passed to print and ordered published by posting by the following vote:

- Ayes: Bartlett, Davila, Hahn, Harrison, Kesarwani, Robinson, Wengraf, and Arreguin.
- Noes: None.
- Absent: Droste.

ORDINANCE NO. 7,647-N.S.

AMENDING BERKELEY MUNICIPAL CODE CHAPTER 23C.25 TO MODIFY THE  
CANNABIS USES ORDINANCE

BE IT ORDAINED by the Council of the City of Berkeley as follows:

Section 1. That Berkeley Municipal Code Chapter 23C.25 is amended to read as follows:

**Chapter 23C.25  
CANNABIS USES**

**Sections:**

**23C.25.010 Retail Uses**

**23C.25.020 Cannabis Cultivation**

**23C.25.030 Manufacturing, Testing and Distribution**

**23C.25.040 Microbusinesses**

**Section 23C.25.010 Retail Uses**

- A. Retailer is defined in Section 12.21.020.
- B. Retailers may not be located within 600 feet of another Retailer or a public or private elementary school, middle school or high school.
- C. Expansion of an approved Retailer shall follow the conversion regulations for the Zoning District in which it is located and shall comply with subdivision (B) of this Section.
- D. An M-Retailer existing and authorized as of January 1, 2010, that does not comply with this Section, may continue at its current medical cannabis dispensing location and shall be considered a legal nonconforming use. Notwithstanding Section 23C.04.060 or subdivision (B) of this Section, the Zoning Officer may approve an Administrative Use Permit to allow the expansion of a legal nonconforming medical cannabis dispensary use on any parcel or on two adjacent parcels where a dispensary was located on one of the parcels as of July 1, 2010.
- E. Cannabis Retailers
  - 1. Seven Cannabis Retailers as defined in Section 12.21.020 shall be permitted as of right with a Zoning Certificate in C-prefixed zones if they comply with the parking requirements applicable to the uses they include, and any security requirements promulgated by the Chief of Police.

1. Retailers shall be approved through a selection process as set forth in Section 12.22.020.
2. No additional Retailers shall be considered for a period of three years from the effective date of this ordinance.

### **Section 23C.25.020 Cannabis Cultivation**

A. Notwithstanding anything to the contrary in this Chapter, cultivation of cannabis as defined in Chapters 12.21 and 12.22 and MAUCRSA, as defined in BMC Section 12.21.010), shall be permitted as a matter of right with a Zoning Certificate in the M District, subject to the following limitations:

1. Such locations shall be limited to licensed Cannabis Businesses.
2. Cannabis may not be dispensed, and client, patient or member services or retail sales are prohibited, at such locations.
3. No single location used for cultivation and associated uses by a licensee may exceed 22,000 square feet of total canopy area, except that separate spaces used by different licensees may be aggregated on the same location.
4. There is no numeric limit for Cannabis Cultivation Facilities under 10,000 sf in total canopy area, up to 48,000 sf.
5. Up to six Major Cannabis Cultivation Facilities between the size of 10,000 sf and 22,000 sf in total canopy area are permitted.
6. Outdoor commercial cultivation is prohibited.
7. The total canopy area used for cannabis cultivation shall not exceed 180,000 square feet.

B. Cannabis nurseries, as defined in Chapter 12.21 are considered Cannabis Cultivation uses and are subject to the same regulations as Cultivators.

C. Such locations shall comply with all regulations in Chapter 12.22, security regulations promulgated by the Chief of Police, and the requirements of this Chapter, and shall not be located within 300 feet of a private or public elementary, middle or high school. Such locations may include testing, processing, manufacturing and food preparation only to the extent expressly permitted by MAUCRSA.

D. No Cannabis uses may be approved under this Section until the City Council adopts a licensing process and standards for such uses. Such standards shall include a



requirement that indoor cultivation uses provide for an energy offset through a program specified by the City to offset the net increased energy that is used by the Facility as compared to a regular industrial facility, and may include, but shall not be limited to, whether proposed Facilities will provide a percentage of all usable product cultivated at no cost to very low income patients and will use organic methods in cultivation and processing to the maximum extent reasonable; and whether their form of organization, ownership and practices ensure equity and accountability, low prices and an adequate supply of high quality cannabis to Customers.

E. Notwithstanding Subsection 23C.25.020.D, Cannabis Cultivators with Cannabis Cultivation Facilities (as defined in Section 12.21.020) that do not exceed 10,000 square feet in total canopy area are permitted as a matter of right with a Zoning Certificate in the M District, subject to a limitation on total canopy area used for Cannabis Cultivation of 180,000 square feet.

**Section 23C.25.030 Cannabis Manufacturing, Testing Labs and Distribution**

A. Uses such as, but not limited to, testing, processing, and food preparation, that involve cannabis as defined in Chapter 12.21 but do not involve dispensing, client, patient or member services, or cultivation (other than for testing), shall be evaluated and regulated under this Title without regard to the fact that they involve cannabis.

B. Manufacturers, Testing Labs, Research and Development and Distribution businesses which are licensed as Cannabis Businesses by the State may not be located within 300 feet of a public or private elementary, middle or high school.

C. For the purposes of this Chapter, the following Cannabis uses shall be evaluated and regulated for Zoning purposes in the same way as the existing non-Cannabis uses, with the exception of distance buffers from schools:

| Cannabis Use                                | Non-Cannabis Use         |
|---------------------------------------------|--------------------------|
| Manufacturing, processing, food preparation | Light Manufacturing      |
| Testing labs                                | Testing labs             |
| Research and Development                    | Research and Development |
| Distribution                                | Wholesale Uses           |

**Section 23C.25.040 Microbusinesses**

A. Microbusinesses are defined in Section 12.21.020

B. Microbusinesses are subject to the development standards set forth in this Chapter for each activity conducted on the premises, with the following exceptions:

1. In cases where the development standards for two activities are different, the more restrictive standards shall apply.
2. Retail Nursery Microbusinesses
  - a. Two existing nurseries are permitted to convert to a Retail Nursery Microbusiness, regardless of the number of Retailers and Cultivators in the City.
  - b. These businesses are permitted by right with a Zoning Certificate in C- and M- prefixed zones, if they comply with the development standards set forth in this Chapter for each activity conducted on the premises.
  - c. If the existing nursery is located entirely or partially in an R-prefixed district, conversion to a Retail Nursery Microbusiness will be subject to requirements for non-conforming uses (Section 23C.04.060).
  - d. The 600-foot retail buffer shall not apply between Storefront Retailers and Retail Nursery Microbusinesses.

Section 2. Copies of this Ordinance shall be posted for two days prior to adoption in the display case located near the walkway in front of Old Berkeley City Hall, 2134 Martin Luther King Jr. Way. Within 15 days of adoption, copies of this Ordinance shall be filed at each branch of the Berkeley Public Library and the title shall be published in a newspaper of general circulation.

At a regular meeting of the Council of the City of Berkeley held on April 2, 2019, this Ordinance was passed to print and ordered published by posting by the following vote:

Ayes: Bartlett, Davila, Hahn, Harrison, Kesarwani, Robinson, Wengraf, and Arreguin.  
Noes: None.  
Absent: Droste.

ORDINANCE NO. 7,648-N.S.

ZONING ORDINANCE AMENDMENT TO SUB-TITLE 23 OF THE BERKELEY MUNICIPAL CODE TO MODIFY DEVELOPMENT STANDARDS AND AMEND USE TABLES RELATED TO CANNABIS USES

BE IT ORDAINED by the Council of the City of Berkeley as follows:

Section 1. That Berkeley Municipal Code Section 23E.16.070 is repealed.

Section 2. That the “Retail Sales” section of Table 23E.36.030 in Berkeley Municipal Code Section 23E.36.030 is amended to read as follows:

**Table 23E.36.030 C-1 General Commercial District Provisions: Uses Permitted**

| Use                                                                    | Classification | Special Requirements (if any)                                                                                                                                                                   |
|------------------------------------------------------------------------|----------------|-------------------------------------------------------------------------------------------------------------------------------------------------------------------------------------------------|
| <b>Retail Sales</b>                                                    |                |                                                                                                                                                                                                 |
| All Retail Sales Uses, except those listed below                       | ZC*            | As defined in Sub-title F, except otherwise listed (does not include Video Rental Stores)                                                                                                       |
| Alcoholic Beverage Retail Sales including Liquor Stores and Wine Shops | UP(PH)         | Includes sale for off-site consumption at restaurants<br>Prohibited within the University Avenue Strategic Plan Overlay (unless in conjunction with a restaurant or general food product store) |
| Department Stores                                                      | ZC*            |                                                                                                                                                                                                 |
| Firearm/Munitions Businesses                                           | UP(PH)         | Prohibited on any property devoted to residential use                                                                                                                                           |
| Pawn Shops, including Auction Houses                                   | UP(PH)         | Prohibited within the University Avenue Strategic Plan Overlay                                                                                                                                  |
| Pet Stores, including Sales and Grooming of Animals (but not Boarding) | UP(PH)         |                                                                                                                                                                                                 |
| Smoke Shops                                                            | UP(PH)         | Prohibited if within 1,400 feet of a school or public park                                                                                                                                      |
| Cannabis Retailer                                                      | ZC             | ZC shall only be issued after business is approved through the selection process<br><br>Subject to the requirements of Chapter 23C.25 and BMC Chapters 12.21 and 12.22                          |

Section 3. That the “Retail Sales” section of Table 23E.40.030 in Berkeley Municipal Code Section 23E.40.030 is amended to read as follows:

**Table 23E.40.030 C-N Neighborhood Commercial District Provisions: Uses Permitted**

| Use                                                                    | Classification    | Special Requirements (if any)                                                                                                                                                                                                                                                                                                                                                                       |
|------------------------------------------------------------------------|-------------------|-----------------------------------------------------------------------------------------------------------------------------------------------------------------------------------------------------------------------------------------------------------------------------------------------------------------------------------------------------------------------------------------------------|
| <b>Retail Sales</b>                                                    |                   |                                                                                                                                                                                                                                                                                                                                                                                                     |
| All Retail Sales Uses, except those listed below                       | ZC*               | As defined in Sub-title F, except otherwise listed. (Does not include Video Rental Stores)                                                                                                                                                                                                                                                                                                          |
| Alcoholic Beverage Retail Sales including liquor stores and wine shops | UP(PH)            | Includes sale for off-site consumption at restaurants                                                                                                                                                                                                                                                                                                                                               |
| Department Stores<br>Over 3,000 s.f.                                   | AUP<br>Prohibited |                                                                                                                                                                                                                                                                                                                                                                                                     |
| Drugstores                                                             | ZC*               | A new or expanded Drugstore is prohibited if it is over 5000 square feet in Gross Floor Area, and within 1000 feet of any property containing an existing Drugstore, as measured by a straight line from the nearest point of the property line of the parcel on which the Drugstore is proposed to the nearest point of the property line of the parcel on which the nearest Drugstore is located. |
| Firearm/Munitions Businesses                                           | UP(PH)            | Prohibited on any property devoted to residential use                                                                                                                                                                                                                                                                                                                                               |
| Pawn Shops, including Auction Houses                                   | Prohibited        |                                                                                                                                                                                                                                                                                                                                                                                                     |
| Pet Stores, including Sales and Grooming of Animals (but not Boarding) | UP(PH)            |                                                                                                                                                                                                                                                                                                                                                                                                     |
| Smoke Shops                                                            | UP(PH)            | Prohibited if within 1,400 feet of a school or public park                                                                                                                                                                                                                                                                                                                                          |
| Cannabis Retailer                                                      | ZC                | ZC shall only be issued after business is approved through the selection process                                                                                                                                                                                                                                                                                                                    |

| Use | Classification | Special Requirements (if any)                                                  |
|-----|----------------|--------------------------------------------------------------------------------|
|     |                | Subject to the requirements of Chapter 23C.25 and BMC Chapters 12.21 and 12.22 |

Section 4. That the "Retail Sales" section of Table 23E.44.030 in Berkeley Municipal Code Section 23E.44.030 is amended to read as follows:

**Table 23E.44.030 C-E Elmwood Commercial District Provisions: Uses Permitted**

| Use                                                                     | Classification    | Special Requirements (if any)                                                                                                                                                                                                                                                                                                                                                                       |
|-------------------------------------------------------------------------|-------------------|-----------------------------------------------------------------------------------------------------------------------------------------------------------------------------------------------------------------------------------------------------------------------------------------------------------------------------------------------------------------------------------------------------|
| <b>Retail Sales</b>                                                     |                   |                                                                                                                                                                                                                                                                                                                                                                                                     |
| All Retail Sales Uses, except those listed below                        | ZC*               | As defined in Sub-title F, except otherwise listed (does not include Video Rental Stores).                                                                                                                                                                                                                                                                                                          |
| Alcoholic Beverage Retail Sales, including liquor stores and wine shops | UP(PH)            | Includes sale for off-site consumption at restaurants                                                                                                                                                                                                                                                                                                                                               |
| Department Stores<br>Over 3,000 s.f.                                    | ZC*<br>Prohibited |                                                                                                                                                                                                                                                                                                                                                                                                     |
| Drugstores                                                              | ZC*               | A new or expanded Drugstore is prohibited if it is over 5000 square feet in Gross Floor Area, and within 1000 feet of any property containing an existing Drugstore, as measured by a straight line from the nearest point of the property line of the parcel on which the Drugstore is proposed to the nearest point of the property line of the parcel on which the nearest Drugstore is located. |
| Firearm/Munitions Businesses                                            | UP(PH)            | Prohibited on any property devoted to residential use                                                                                                                                                                                                                                                                                                                                               |
| Pawn Shops, including Auction Houses                                    | Prohibited        |                                                                                                                                                                                                                                                                                                                                                                                                     |
| Pet Stores, including Sales and Grooming of Animals                     | UP(PH)            | Does not include boarding of animals                                                                                                                                                                                                                                                                                                                                                                |
| Smoke Shops                                                             | UP(PH)            | Prohibited if within 1,400 feet of a school or public park                                                                                                                                                                                                                                                                                                                                          |
| Cannabis Retailer                                                       | ZC                | ZC shall only be issued after business is approved through the selection process                                                                                                                                                                                                                                                                                                                    |

| Use | Classification | Special Requirements (if any)                                                  |
|-----|----------------|--------------------------------------------------------------------------------|
|     |                | Subject to the requirements of Chapter 23C.25 and BMC Chapters 12.21 and 12.22 |

Section 5. That the "Retail Sales" section of Table 23E.48.030 in Berkeley Municipal Code Section 23E.48.030 is amended to read as follows:

**Table 23E.48.030 C-NS North Shattuck Commercial District Provisions: Uses Permitted**

| Use                                                                     | Classification    | Special Requirements (if any)                                                                                                                                                                                                                                                                                                                                                                       |
|-------------------------------------------------------------------------|-------------------|-----------------------------------------------------------------------------------------------------------------------------------------------------------------------------------------------------------------------------------------------------------------------------------------------------------------------------------------------------------------------------------------------------|
| <b>Retail Sales</b>                                                     |                   |                                                                                                                                                                                                                                                                                                                                                                                                     |
| All Retail Sales Uses, except those listed below                        | ZC*               | As defined in Sub-title F, except otherwise listed (does not include Video Rental Stores).                                                                                                                                                                                                                                                                                                          |
| Alcoholic Beverage Retail Sales, including liquor stores and wine shops | UP(PH)            | Includes sale for off-site consumption at restaurants                                                                                                                                                                                                                                                                                                                                               |
| Department Stores<br>Over 3,000 s.f.                                    | ZC*<br>Prohibited |                                                                                                                                                                                                                                                                                                                                                                                                     |
| Drugstores                                                              | ZC*               | A new or expanded Drugstore is prohibited if it is over 5000 square feet in Gross Floor Area, and within 1000 feet of any property containing an existing Drugstore, as measured by a straight line from the nearest point of the property line of the parcel on which the Drugstore is proposed to the nearest point of the property line of the parcel on which the nearest Drugstore is located. |
| Firearm/Munitions Businesses                                            | UP(PH)            | Prohibited on any property devoted to residential use                                                                                                                                                                                                                                                                                                                                               |
| Pawn Shops, including Auction Houses                                    | Prohibited        |                                                                                                                                                                                                                                                                                                                                                                                                     |
| Pet Stores, including Sales and Grooming of Animals (but not Boarding)  | UP(PH)            |                                                                                                                                                                                                                                                                                                                                                                                                     |
| Smoke Shops                                                             | UP(PH)            | Prohibited if within 1,400 feet of a school or public park                                                                                                                                                                                                                                                                                                                                          |
| Cannabis Retailer                                                       | ZC                | ZC shall only be issued after business is approved through the selection process                                                                                                                                                                                                                                                                                                                    |

| Use | Classification | Special Requirements (if any)                                                  |
|-----|----------------|--------------------------------------------------------------------------------|
|     |                | Subject to the requirements of Chapter 23C.25 and BMC Chapters 12.21 and 12.22 |

Section 6. That the “Retail Sales” section of Table 23E.52.030 in Berkeley Municipal Code Section 23E.52.030 is amended to read as follows:

**Table 23E.52.030 C-SA South Area Commercial District Provisions: Uses Permitted**

| Use                                                                     | Classification | Special Requirements (if any)                                                                                                                                          |
|-------------------------------------------------------------------------|----------------|------------------------------------------------------------------------------------------------------------------------------------------------------------------------|
| <b>Retail Sales</b>                                                     |                |                                                                                                                                                                        |
| All Retail Sales Uses, except those listed below                        | ZC*            | As defined in Sub-title F, except otherwise listed (does not include Video Rental Stores)                                                                              |
| Alcoholic Beverage Retail Sales, including liquor stores and wine shops | UP(PH)         | Includes sale for off-site consumption at restaurants<br>No sales of distilled alcoholic beverages are allowed along Adeline Street south of Ashby Avenue              |
| Department Stores<br>Over 3,000 s.f.                                    | ZC*<br>UP(PH)  |                                                                                                                                                                        |
| Firearm/Munitions Businesses                                            | UP(PH)         | Prohibited on any property devoted to residential use                                                                                                                  |
| Pawn Shops                                                              | Prohibited     | Including Auction Houses                                                                                                                                               |
| Pet Stores                                                              | UP(PH)         | Including Sales and Grooming of Animals (but not Boarding)                                                                                                             |
| Smoke Shops                                                             | UP(PH)         | Prohibited if within 1,400 feet of a school or public park                                                                                                             |
| Cannabis Retailer                                                       | ZC             | ZC shall only be issued after business is approved through the selection process<br><br>Subject to the requirements of Chapter 23C.25 and BMC Chapters 12.21 and 12.22 |

Section 7. That the “Retail Sales” section of Table 23E.56.030 in Berkeley Municipal Code Section 23E.56.030 is amended to read as follows:

**Table 23E.56.030 C-T Telegraph Avenue Commercial District Provisions: Uses Permitted**

| Use                                                                     | Classification | Special Requirements (if any)                                                                                                                                          |
|-------------------------------------------------------------------------|----------------|------------------------------------------------------------------------------------------------------------------------------------------------------------------------|
| <b>Retail Sales</b>                                                     |                |                                                                                                                                                                        |
| All Retail Sales Uses, except those listed below                        | ZC             | As defined in Sub-title 23F, except otherwise listed (does not include Video Rental Stores)                                                                            |
| Alcoholic Beverage Retail Sales including liquor stores and wine shops  | Prohibited     | Includes sale for off-site consumption at restaurants                                                                                                                  |
| Department Stores Over 3,000 s.f.                                       | ZC<br>UP(PH)   |                                                                                                                                                                        |
| Drug Paraphernalia (any use involving the sale or distribution thereof) | Prohibited     | As defined in California Health and Safety Code Section 11364.5(d)                                                                                                     |
| Firearm/Munitions Businesses                                            | UP(PH)         | Prohibited on any property devoted to residential use                                                                                                                  |
| Pawn Shops                                                              | Prohibited     | Including Auction Houses                                                                                                                                               |
| Pet Stores                                                              | UP(PH)         | Including Sales and Grooming of Animals (but not Boarding)                                                                                                             |
| Smoke Shops                                                             | UP(PH)         | Prohibited if within 1,400 feet of a school or public park                                                                                                             |
| Cannabis Retailer                                                       | ZC             | ZC shall only be issued after business is approved through the selection process<br><br>Subject to the requirements of Chapter 23C.25 and BMC Chapters 12.21 and 12.22 |

Section 8. That the "Retail Sales" section of Table 23E.60.030 in Berkeley Municipal Code Section 23E.60.030 is amended to read as follows:

**Table 23E.60.030 C-SO Solano Avenue Commercial District Provisions: Uses Permitted**

| Use                                                                     | Classification | Special Requirements (if any)                                                             |
|-------------------------------------------------------------------------|----------------|-------------------------------------------------------------------------------------------|
| <b>Retail Sales</b>                                                     |                |                                                                                           |
| All Retail Sales Uses, except those listed below                        | ZC*            | As defined in Sub-title F, except otherwise listed (does not include Video Rental Stores) |
| Alcoholic Beverage Retail Sales, including liquor stores and wine shops | UP(PH)         | Includes sale for off-site consumption at restaurants                                     |
| Department Stores                                                       | ZC*            |                                                                                           |



| Use                                                                   | Classification | Special Requirements (if any)                                                                                                                                                                                                                                                                                                                                                                       |
|-----------------------------------------------------------------------|----------------|-----------------------------------------------------------------------------------------------------------------------------------------------------------------------------------------------------------------------------------------------------------------------------------------------------------------------------------------------------------------------------------------------------|
| Over 3,000 s.f.                                                       | Prohibited     |                                                                                                                                                                                                                                                                                                                                                                                                     |
| Drugstores                                                            | ZC*            | A new or expanded Drugstore is prohibited if it is over 5000 square feet in Gross Floor Area, and within 1000 feet of any property containing an existing Drugstore, as measured by a straight line from the nearest point of the property line of the parcel on which the Drugstore is proposed to the nearest point of the property line of the parcel on which the nearest Drugstore is located. |
| Firearm/Munitions Businesses                                          | UP(PH)         | Prohibited on any property devoted to residential use                                                                                                                                                                                                                                                                                                                                               |
| Pawn Shops                                                            | Prohibited     |                                                                                                                                                                                                                                                                                                                                                                                                     |
| Pet Stores including Sales and Grooming of Animals (but not Boarding) | UP(PH)         |                                                                                                                                                                                                                                                                                                                                                                                                     |
| Smoke Shops                                                           | UP(PH)         | Prohibited if within 1,400 feet of a school or public park                                                                                                                                                                                                                                                                                                                                          |
| Cannabis Retailer                                                     | ZC             | ZC shall only be issued after business is approved through the selection process<br><br>Subject to the requirements of Chapter 23C.25 and BMC Chapters 12.21 and 12.22                                                                                                                                                                                                                              |

Section 9. That the "Retail Sales" section of Table 23E.64.030 in Berkeley Municipal Code Section 23E.64.030 is amended to read as follows:

**Table 23E.64.030 C-W West Berkeley Commercial District Provisions: Uses Permitted**

| Use                                                               | Permits Required to Establish, Expand or Change Use (sq. ft.) |             |               | Special Requirements (if any)                                                                     |
|-------------------------------------------------------------------|---------------------------------------------------------------|-------------|---------------|---------------------------------------------------------------------------------------------------|
| <b>Retail Sales</b>                                               |                                                               |             |               |                                                                                                   |
| Retail uses as defined in Sub-title 23F, except otherwise listed. |                                                               |             |               |                                                                                                   |
|                                                                   | Under 3,500                                                   | 3,500-7,500 | 7,500 or more |                                                                                                   |
| All Retail Sales Uses, except those specified below               | ZC                                                            | AUP         | UP(PH)<br>**  | **Except when part of a combination commercial/residential use; see Mixed Use Development heading |

| Use                                                                     | Permits Required to Establish, Expand or Change Use (sq. ft.) | Special Requirements (if any)                                                                                                                                          |
|-------------------------------------------------------------------------|---------------------------------------------------------------|------------------------------------------------------------------------------------------------------------------------------------------------------------------------|
| Alcoholic Beverage Retail Sales, including liquor stores and wine shops | UP(PH)                                                        | Includes sale for off-site consumption at restaurants                                                                                                                  |
| Firearm/Munitions Businesses                                            | UP(PH)                                                        | Prohibited on any property devoted to residential use                                                                                                                  |
| Pawn Shops, including Auction Houses                                    | UP(PH)                                                        |                                                                                                                                                                        |
| Smoke Shops                                                             | UP(PH)                                                        | Prohibited if within 1,400 feet of a school or public park                                                                                                             |
| Cannabis Retailer                                                       | ZC                                                            | ZC shall only be issued after business is approved through the selection process<br><br>Subject to the requirements of Chapter 23C.25 and BMC Chapters 12.21 and 12.22 |

Section 10. That the “Retail Sales” section of Table 23E.68.030 in Berkeley Municipal Code Section 23E.68.030 is amended to read as follows:

**Table 23E.68.030 C-DMU Downtown Mixed Use Commercial District Provisions: Uses Permitted**

| Use                                                                     | Classification | Special Requirements                                  |
|-------------------------------------------------------------------------|----------------|-------------------------------------------------------|
| <b>Retail Sales</b>                                                     |                |                                                       |
| All Retail Sales Uses, except those listed below                        | ZC             | As defined in Sub-title 23F, except otherwise listed  |
| Alcoholic Beverage Retail Sales, including liquor stores and wine shops | UP(PH)         | Includes sale for off-site consumption at restaurants |
| Department Stores<br>Under 10,000 s.f.                                  | AUP<br>ZC      |                                                       |
| Firearm/Munitions Businesses                                            | Prohibited     |                                                       |
| Pawn Shops, including Auction Houses                                    | UP(PH)         |                                                       |
| Pet Stores, including Sales and Grooming of Animals (but not Boarding)  | UP(PH)         |                                                       |
| Smoke Shops                                                             | Prohibited     |                                                       |

| Use               | Classification | Special Requirements                                                                                                                                                   |
|-------------------|----------------|------------------------------------------------------------------------------------------------------------------------------------------------------------------------|
| Cannabis Retailer | ZC             | ZC shall only be issued after business is approved through the selection process<br><br>Subject to the requirements of Chapter 23C.25 and BMC Chapters 12.21 and 12.22 |

Section 11. That the “Other Industrial Uses” section of Table 23E.72.030 in Berkeley Municipal Code Section 23E.72.030 is amended to read as follows:

**Table 23E.72.030 M Manufacturing District Provisions: Uses Permitted**

| Uses                                                     | Permits Required to Establish, Expand or Change Use (sq. ft.) |                     |                  | Special Requirements (if any)                                                                                             |
|----------------------------------------------------------|---------------------------------------------------------------|---------------------|------------------|---------------------------------------------------------------------------------------------------------------------------|
|                                                          | Under 20,000                                                  | 20,000 – 40,000     | More than 40,000 |                                                                                                                           |
| <b>Other Industrial Uses</b>                             |                                                               |                     |                  |                                                                                                                           |
| Art/Craft Studio                                         | ZC <10,000                                                    | AUP 10,000 – 20,000 | UP(PH) >20,000   | Workspaces only, no Live/Work permitted.                                                                                  |
| Bus, cab, truck and public utility depots                | AUP                                                           | UP                  |                  |                                                                                                                           |
| Commercial Excavation                                    | UP(PH)                                                        |                     |                  | Including earth, gravel, minerals, or other building materials, including drilling for, or removal of, oil or natural gas |
| Contractors                                              | AUP                                                           |                     | UP               |                                                                                                                           |
| Dry Cleaning and Laundry Plants                          | ZC                                                            | AUP                 | UP(PH)           | No retail service permitted                                                                                               |
| Laboratories, Testing and Commercial Biological Research | Prohibited                                                    |                     |                  |                                                                                                                           |
| Media Production                                         | ZC <10,000                                                    | AUP 10,000 – 20,000 | UP(PH) >20,000   |                                                                                                                           |
| Recycled Materials Processing                            | ZC*                                                           | AUP                 | UP               | * If all processing done indoors; if any outdoors, AUP                                                                    |

|                                         |     |     |    |                                                                                                                                                                                                                                    |
|-----------------------------------------|-----|-----|----|------------------------------------------------------------------------------------------------------------------------------------------------------------------------------------------------------------------------------------|
| Repair Service (other than auto repair) | ZC  | AUP | UP | No retail sales permitted                                                                                                                                                                                                          |
| Services to Buildings and Dwellings     | AUP |     |    |                                                                                                                                                                                                                                    |
| Cannabis Cultivation                    | ZC  |     |    | For Large Cultivators (over 10,000 square feet of canopy) a ZC shall only be issued after business is approved through the selection process<br><br>Subject to the requirements of Chapter 23C.25 and BMC Chapters 12.21 and 12.22 |

Section 12. Copies of this Ordinance shall be posted for two days prior to adoption in the display case located near the walkway in front of Old Berkeley City Hall, 2134 Martin Luther King Jr. Way. Within 15 days of adoption, copies of this Ordinance shall be filed at each branch of the Berkeley Public Library and the title shall be published in a newspaper of general circulation.

At a regular meeting of the Council of the City of Berkeley held on April 2, 2019, this Ordinance was passed to print and ordered published by posting by the following vote:

Ayes: Bartlett, Davila, Hahn, Harrison, Kesarwani, Robinson, Wengraf, and Arreguin.

Noes: None.

Absent: Droste.

ORDINANCE NO. 7,649-N.S.

ZONING ORDINANCE AMENDMENT TO CHAPTER 23F.04 OF THE BERKELEY MUNICIPAL CODE TO ADD AND MODIFY DEFINITIONS RELATED TO CANNABIS USES

BE IT ORDAINED by the Council of the City of Berkeley as follows:

Section 1. That Berkeley Municipal Code Chapter 23F.04 is amended to revise the definition of “Cannabis Uses”, add the definition of “Microbusiness” in alphabetical order, and amend the definition of Retail Products Store” as follows:

**Cannabis Uses:** Cannabis uses include retail sales, cultivation, manufacturing, testing, and distributing. See BMC Chapters 12.21, and 12.22 for cannabis regulations and Section 23C.25 for land use regulations.

**Microbusiness:** Cannabis use involving more than one State license. See BMC Chapter 12.21 for definition.

**Retail Nursery Microbusiness:** A microbusiness that is restricted to growing and selling cannabis plants and seeds. See BMC Chapter 12.21 for definition.

**Retail Products Store:** An establishment engaged in the sales of personal, consumer or household items to the customers who will use such items, including, but not limited to:

| <b>Retail Products Stores</b>                 | <b>Comments</b>                               |
|-----------------------------------------------|-----------------------------------------------|
| Antique Stores                                | Includes Collectibles                         |
| Art/Craft Shops                               |                                               |
| Art Galleries                                 |                                               |
| Art and Craft Supply Stores                   |                                               |
| Audio/Video Records, Tapes, Disks Sales Shops | Excludes video rental stores                  |
| Automobile Parts Stores                       | Excludes service of auto parts                |
| Bicycle Shops                                 | Includes sales, parts and repair/service      |
| Bookstores, Periodical Stands                 |                                               |
| Clothing Stores                               | Includes apparel, hats, shoes and accessories |
| Computer Stores                               | Hardware and software                         |

| <b>Retail Products Stores</b>                                              | <b>Comments</b>                                                                       |
|----------------------------------------------------------------------------|---------------------------------------------------------------------------------------|
| Drugstores                                                                 | Includes pharmaceutical, sundries, cosmetic/personal care items                       |
| Fabric, Textile and Sewing Supply Shops                                    |                                                                                       |
| Flower and Plant Stores                                                    | Includes live, fresh-cut and/or dried flowers; excludes nurseries                     |
| Food Products Stores, Specialized                                          | Includes Bakeries                                                                     |
| Food Products Stores, General                                              | Includes groceries, markets and supermarkets                                          |
| Furniture Stores, Household or Office                                      | Includes carpets and rugs                                                             |
| Garden Supply Stores, Nurseries                                            | Does not include Cannabis Nurseries, see Cannabis Cultivation definition in 12.21.020 |
| Gift/Novelty Shops                                                         |                                                                                       |
| Glass Pane and Mirror Stores                                               |                                                                                       |
| Hobby Shops                                                                |                                                                                       |
| Household Hardware and Housewares Stores                                   |                                                                                       |
| Household Electronics/Electrical Stores<br>(Audio, Telephone and Video/TV) | Excludes video rental stores                                                          |
| Jewelry/Watch Shops                                                        |                                                                                       |
| Linen Shops                                                                | Includes bedding                                                                      |
| Musical Instruments and Materials Stores                                   |                                                                                       |
| Office Supply Stores                                                       |                                                                                       |
| Paint/Wallpaper Stores                                                     |                                                                                       |
| Photography Equipment Supply Stores                                        | Includes cameras and film developing                                                  |
| Secondhand Stores                                                          | Includes used/vintage clothing and household goods                                    |
| Small Appliance Stores                                                     |                                                                                       |
| Sporting Goods Stores                                                      | Includes equipment, clothing and supplies, excluding Firearm/Munitions Businesses     |

| Retail Products Stores                   | Comments |
|------------------------------------------|----------|
| Stationery, Cards and Paper Goods Stores |          |
| Toy Stores                               |          |
| Variety Stores                           |          |

Section 2. Copies of this Ordinance shall be posted for two days prior to adoption in the display case located near the walkway in front of Old Berkeley City Hall, 2134 Martin Luther King Jr. Way. Within 15 days of adoption, copies of this Ordinance shall be filed at each branch of the Berkeley Public Library and the title shall be published in a newspaper of general circulation.

At a regular meeting of the Council of the City of Berkeley held on April 2, 2019, this Ordinance was passed to print and ordered published by posting by the following vote:

Ayes: Bartlett, Davila, Hahn, Harrison, Kesarwani, Robinson, Wengraf, and Arreguin.

Noes: None.

Absent: Droste.







Office of the City Manager

CONSENT CALENDAR  
April 23, 2019

To: Honorable Mayor and Members of the City Council

From: Dee Williams-Ridley, City Manager

Submitted by: Jordan Klein, Economic Development Manager

Subject: Contract: Masayuki Nagase for North Berkeley Senior Center Measure T1 Public Art Commission

RECOMMENDATION

Adopt a Resolution authorizing the City Manager to execute a contract for an amount not to exceed \$100,000, and any amendments thereto, with Masayuki Nagase for a public art commission for North Berkeley Senior Center.

FISCAL IMPACTS OF RECOMMENDATION

The \$100,000 contract will be funded with Measure T1 bond funds. Funding for public art was set aside in the Measure T1 budget in accordance with Council Resolution 60,048-N.S., "A sum equal to one percent (1%) of the Project Budget for each Eligible Capital Project shall be transferred to the Public Art Fund and utilized solely to develop and install a work of art integrated into the completed improvement..." Measure T1 Phase One generated \$350,000 for public art, of which the Civic Arts Commission allocated \$100,000 for implementation of a project to be integrated into the improvements at North Berkeley Senior Center.

CURRENT SITUATION AND ITS EFFECTS

The North Berkeley Senior Center Public Art Project is a Strategic Plan Priority Project, advancing our goal to provide state-of-the-art, well-maintained infrastructure, amenities, and facilities. The North Berkeley Senior Center, located at 1901 Hearst Avenue at Martin Luther King, Jr. Way, is a dynamic community resource offering a variety of activities, classes, and services for seniors. This facility is undergoing renovations, funded by the Measure T1 Bond, to modernize the interior and provide much needed upgrades to improve the safety and functionality of the building, including seismic upgrades for "care and shelter" requirements.

As part of these improvements the City of Berkeley is commissioning a functional artwork for the entry plaza to the center. The entry plaza will feature seating and planted areas and will be a space where building users can gather to socialize, play games and enjoy time spent outdoors. The artwork will complement the plaza design, help beautify the space and contribute to the unique identity of the senior center.

## BACKGROUND

A Request for Qualifications was released on September 11, 2018 and was open through October 23, 2018. A selection panel comprised of arts professionals reviewed the qualifications of the 42 applicants and recommended 19 applications to be presented to the North Berkeley Senior Center Public Art Project selection panel, which was comprised of arts professionals, representatives from the Civic Arts Commission and the Commission on Aging, a Public Works Measure T1 project team member, and a North Berkeley Senior Center community representative. This panel reviewed the qualifications of the 19 artists on the short list and selected three finalists who were invited to develop site specific public art project proposals. The proposals were displayed to gather public comment for two weeks on the City's website and for one week each at the West Berkeley Senior Center and the South Berkeley Senior Center. The North Berkeley Senior Center Public Art Project selection panel reconvened to evaluate the three proposals and they selected the proposal by Masayuki Nagase for recommendation to the Civic Arts Commission.

Masayuki Nagase's proposal to create a large carved granite seating element and a series of carved granite pavers for the entry plaza was approved by the Civic Arts Commission at its meeting on February 27, 2019 (Motion/Second: Passmore/Blecher; Ayes: Anno, Blecher, Bullwinkel, Covarrubias, Ozol, Passmore, Ross, Slattery, Tamano; Nays: None; Abstain: None; Absent: None). The contract with Masayuki Nagase will be for design development, structural engineering, fabrication, and installation of the artwork at the North Berkeley Senior Center.

## ENVIRONMENTAL SUSTAINABILITY

There are no identifiable environmental effects or opportunities associated with the content of this report.

## RATIONALE FOR RECOMMENDATION

The proposal by Masayuki Nagase was selected based upon the following criteria: aesthetic quality; appropriateness of the proposed artwork for the site and project goals; demonstrated feasibility of the preliminary proposal and the proposal budget; and demonstrated maintainability and durability of the artworks design, materials, fabrication and installation methods.

## ALTERNATIVE ACTIONS CONSIDERED

The selection panel considered two other proposals.

## CONTACT PERSON

Jordan Klein, Economic Development Manager, (510) 981-7534  
Jennifer Lovvorn, Civic Arts Coordinator, (510) 981-7533

## Attachments:

- 1: Resolution
2. Artwork Proposal for North Berkeley Senior Center by Masayuki Nagase

RESOLUTION NO. ##,###-N.S.

CONTRACT WITH MASAYUKI NAGASE TO CREATE A PUBLIC ARTWORK FOR  
NORTH BERKELEY SENIOR CENTER

WHEREAS, the City of Berkeley seeks to engage an artist to create a work of public art at North Berkeley Senior Center in conjunction with the Measure T1 infrastructure improvements in order to enhance the facility and expand the community's public art resources; and

WHEREAS, funding for public art was set aside in the Measure T1 budget in accordance with Council Resolution 60,048-N.S.; and

WHEREAS, a Request for Qualifications from professional practicing artists was released on September 11, 2018 and subsequently 42 submissions were received; and

WHEREAS, a selection panel comprised of arts professionals reviewed the qualifications of the 42 applicants and recommended 19 applications to be presented to the North Berkeley Senior Center Public Art Project selection panel, which was comprised of arts professionals, representatives from the Civic Arts Commission and the Commission on Aging, a Public Works Measure T1 project team member, and a North Berkeley Senior Center community representative; and

WHEREAS, the North Berkeley Senior Center Public Art Project selection panel reviewed the qualifications of the 19 artists on the short list and selected three finalists who were invited to develop site specific public art project proposals; and

WHEREAS, the North Berkeley Senior Center Public Art Project selection panel reconvened to evaluate the three proposals and they selected the proposal by Masayuki Nagase for recommendation to the Civic Arts Commission; and

WHEREAS, Masayuki Nagase's proposal to create a large carved granite seating element and a series of carved granite pavers for the entry plaza of North Berkeley Senior Center was approved by the Civic Arts Commission at its meeting on February 27, 2019.

NOW THEREFORE, BE IT RESOLVED by the Council of the City of Berkeley that the City Manager is authorized to execute a contract and any amendments thereto with Masayuki Nagase for a public artwork for North Berkeley Senior Center for an amount not to exceed \$100,000. A record signature copy of said contract and any amendments are to be on file in the Office of the City Clerk.

# Masayuki Nagase North Berkeley Senior Center Public Art Proposal "Song of Trees"

### ENTRY PLAZA ART ELEMENTS LOCATION

### North Berkeley Senior Center Public Art Proposal "Song of Trees" Masayuki Nagase

When I visited the North Berkeley Senior Center, I could feel this place vitalized so many people's lives in a variety of ways. Since I always work with the theme of nature I envisioned how throughout history, people would choose a prominent tree as a spiritual marker and a gathering place for their community.

Trees are the longest living organisms on earth. They create oxygen for all life, carry the essence of abundance, growth and rebirth. I chose the tree as the main metaphor of the artwork representing unity, community and diversity. The North Berkeley Senior Center's essence is like the deep-rooted trees that endure and nourish and inspire us.

Additionally, I propose to have a design community workshop where I can find out what inspires the community here about nature and trees. I would like to then integrate meaningful quotes or poems that community members choose and integrate into the artwork in the plaza.

The artwork consists of three elements located in and around an entry plaza for the main building.

The 1st elements are 2 stone panels placed in the walls for the 2 main entrance walkways into the entry plaza. Each panel will have a design of 2 different types of trees and these panels will act as visual markers for visitors.

The 2nd element is a stone table-bench with a design based on the Redwood tree and placed in the entry plaza. This element represents community.

The 3rd element is a series of circular stone pavers with images of varied types of trees and placed in the entry plaza. This element represents diversity.

### ENTRY PLAZA TABLE-BENCH

This stone table-bench sculpture is a functional art element and acts as a main focal point in the entry plaza.

The design of the sculpture is based on the Coast Redwood tree. The sides of the table-bench will have a hand carved texture like the bark of the tree. The top surface of the table-bench will be engraved with an abstract pattern based on Redwood cone and leaves.

### ENTRY PLAZA TABLE-BENCH

**PLAN**

5' - 5' 6"

**ELEVATION**

18" - 20"

### ENTRY PLAZA STONE PAVERS

|            |                |            |                |
|------------|----------------|------------|----------------|
| 1<br># 12" | Hazelnut       | 5<br># 30" | Big Leaf Maple |
| 2<br># 14" | CA. Bay Laurel | 6<br># 36" | Valley Oak     |
| 3<br># 20" | Coast Live Oak | 7<br># 36" | Sycamore       |
| 4<br># 24" | Eucalyptus     |            |                |

### WALL A and WALL B with STONE PANELS

There are two low walls on the main entrance walkways to the plaza facing the streets of Martin Luther King, Jr. Way and Hearst Ave.

I propose to place a stone panel in each wall. They will be engraved with two different designs based on native trees. These panels will enhance the walls and give additional visual markers as the visitors enter the plaza.

**WALL A**

**WALL B**

### STONE WALL PANEL A (California Bay Laurel)

### STONE WALL PANEL B (California Buckeye)

### COLOR and TEXTURE SAMPLE

## **Proposal Narrative**

When I visited the North Berkeley Senior Center, I could feel this place vitalized so many people's lives in a variety of ways. Since I always work with the theme of nature I envisioned how throughout history, people would choose a prominent tree as a spiritual marker and a gathering place for their community.

Trees are the longest living organisms on earth. They are essential, creating oxygen for all life. Trees carry the essence of abundance, growth, and rebirth. I chose the tree as the main metaphor of the artwork representing unity, community and diversity. The North Berkeley Senior Center's essence is like the deep-rooted trees that endure and nourish and inspire us.

Additionally, I propose to have a design community workshop where I can find out what inspires the community here about nature and trees. I would like to then integrate meaningful quotes or poems that community members choose and integrate into the artwork in the plaza.

The artwork consists of three elements located in and around an entry plaza for the main building.

The 1st elements are two stone panels placed in the walls for the 2 main entrance walkways into the entry plaza. Each panel will have a design of 2 different types of trees and these panels will act as visual markers for visitors.

Material: Granite  
Color: Dark gray, Black  
Panel dimensions: Width 4 ft. Height 2 ft.

The 2nd element is a stone table-bench with a design based on the Redwood tree and placed in the entry plaza. This element represents Community. This element represents community.

Material: Granite  
Color: Dark gray, Black  
Dimension: Diameter 5 ft. Height 18 inches

The 3rd element is a series of circular stone pavers with images of varied types of trees and placed in the entry plaza. These pavers represent Diversity.

Material: Granite  
Color: Dark gray, Black  
Dimensions: Series of 7 pavers. Diameter ranges from 12 inches to 3 ft.

Additional community involvement component will be discussed in detail in the future design development phase. Preliminary ideas would be integrating quotes or phrases from poems in the paving or wall areas.

**Maintenance:**

Cleaning with water and light detergent as needed (every few months) to remove dirt and stains when necessary.

**Artist's role on the project:**

Artist will be the main fabricator of the stone elements. Subcontractors will prepare the stone material such as saw cuts, polishing and some sandblasting.

**Preliminary Description of Work Process and Timeline**

**I. RESEARCH PHASE** **1-3 months**

- a) Finalize schematic design details, plans and contract
- b) Coordinate with design team all design details and material selections
- c) Select structural engineer for concrete foundation for table-bench and other elements.
- d) Select subcontractors for preparation of stone materials including polishing and sandblasting and for concrete foundation
- e) Select stone materials and order saw cuts in factory

**II. FABRICATION PHASE** **2-3 months**

- a) Fabrication of table-bench in studio by artist
- b) Fabrication of sandblasted, engraved pavers by subcontractor

**III. SITE PREPARATION PHASE** **1 month**

- a) Pouring of the concrete foundation for the table-bench by subcontractor
- b) Preparation of paving area and concrete foundation by artist

**IV. INSTALLATION PHASE** **1-2 months**

- a) Transportation of table-bench to the site by trucking company
- b) Installation of table-bench by subcontractor
- c) Transportation of granite panels and pavers by artist or subcontractor
- d) Installation of granite panels by subcontractor
- e) Installation of granite pavers by subcontractor



Office of the City Manager

CONSENT CALENDAR  
April 23, 2019

To: Honorable Mayor and Members of the City Council  
 From: Dee Williams-Ridley, City Manager  
 Submitted by: Henry Oyekanmi, Director, Finance  
 Subject: Formal Bid Solicitations and Request for Proposals Scheduled for Possible Issuance After Council Approval on April 23, 2019

RECOMMENDATION

Approve the request for proposals or invitation for bids (attached to staff report) that will be, or are planned to be, issued upon final approval by the requesting department or division. All contracts over the City Manager's threshold will be returned to Council for final approval.

FISCAL IMPACTS OF RECOMMENDATION

Total estimated cost of items included in this report is \$5,680,000.

| <u>PROJECT</u>                                     | <u>Fund</u> | <u>Source</u>               | <u>Amount</u>             |
|----------------------------------------------------|-------------|-----------------------------|---------------------------|
| Live Oak Community Center Seismic Retrofit Project | 511         | Measure T1 – Infrastructure | \$5,300,000               |
| John Hinkel Park Improvements                      | 345         | Measure WW – Park Bond      | \$380,000                 |
| <b>Total:</b>                                      |             |                             | <b><u>\$5,680,000</u></b> |
|                                                    |             |                             |                           |

CURRENT SITUATION AND ITS EFFECTS

On May, 6, 2008, Council adopted Ordinance No. 7,035-N.S. effective June 6, 2008, which increased the City Manager's purchasing authority for services to \$50,000. As a result, this required report submitted by the City Manager to Council is now for those purchases in excess of \$100,000 for goods; and \$200,000 for playgrounds and construction; and \$50,000 for services. If Council does not object to these items being sent out for bid or proposal within one week of them appearing on the agenda, and

Formal Bid Solicitations and Request for Proposals  
Scheduled for Possible Issuance After Council  
Approval on April 23, 2019

CONSENT CALENDAR  
April 23, 2019

upon final notice to proceed from the requesting department, the IFB or RFP may be released to the public and notices sent to the potential bidder/respondent list.

### BACKGROUND

On May 6, 2008, Council adopted Ordinance No. 7,035-N.S., amending the City Manager's purchasing authority for services.

### ENVIRONMENTAL SUSTAINABILITY

The Finance Department reviews all formal bid and proposal solicitations to ensure that they include provisions for compliance with the City's environmental policies. For each contract that is subject to City Council authorization, staff will address environmental sustainability considerations in the associated staff report to City Council.

### CONTACT PERSON

Shari Hamilton, General Services Manager, Finance, 510-981-7329

### Attachments:

1: Formal Bid Solicitations and Request for Proposals Scheduled For Possible Issuance After Council Approval on April 23, 2019

- a) Live Oak Community Seismic Retrofit Project
- b) John Hinkel Park Improvements

Note: Original of this attachment with live signature of authorizing personnel is on file in General Services.



DATE SUBMITTED: April 23, 2019

| SPECIFICATION NO.  | DESCRIPTION OF GOODS / SERVICES BEING PURCHASED    | APPROX. RELEASE DATE | APPROX. BID OPENING DATE | INTENDED USE                                                                                                                                                                                                                                                                                                                                                                                       | ESTIMATED COST | BUDGET CODE TO BE CHARGED                     | DEPT. / DIVISION                                        | CONTACT NAME & PHONE        |
|--------------------|----------------------------------------------------|----------------------|--------------------------|----------------------------------------------------------------------------------------------------------------------------------------------------------------------------------------------------------------------------------------------------------------------------------------------------------------------------------------------------------------------------------------------------|----------------|-----------------------------------------------|---------------------------------------------------------|-----------------------------|
| 19-11320-C         | Live Oak Community Center Seismic Retrofit Project | 6/21/2019            | 7/25/2019                | Project consists of a seismic retrofit of the Live Oak Community center to reach Immediate Occupancy rating to serve as a care and shelter facility. Upgrades also include a new ADA restroom in the theater, ADA ramp to entrances to the center and theater, addition for staff seating and storage, energy efficiency upgrades to the HVAC system, and various building code required upgrades. | \$5,300,000    | 511-52-545-000-0000-000-461-662110-PRWT119005 | No<br><br>Funds will be appropriated in 1st AAO of FY20 | Taylor Lancelot<br>981-6421 |
| <b>DEPT. TOTAL</b> |                                                    |                      |                          |                                                                                                                                                                                                                                                                                                                                                                                                    | \$5,300,000    |                                               |                                                         |                             |
| 19-11321-C         | John Hinkel Park Improvements                      | 4/24/2019            | 6/4/2019                 | This project will create a picnic site at the former club house building pad. Accessible pathway, concrete patio, and walls will be constructed along with irrigation and planting. The project will also renovate the entry stairway at Somerset Place.                                                                                                                                           | \$380,000      | 345-52-545-000-0000-000-461-663110-PRWPK14002 | PRW? Capital Project                                    | Wendy Wellbrock<br>981-6346 |
| <b>DEPT. TOTAL</b> |                                                    |                      |                          |                                                                                                                                                                                                                                                                                                                                                                                                    | \$380,000      |                                               |                                                         |                             |
| <b>GRAND TOTAL</b> |                                                    |                      |                          |                                                                                                                                                                                                                                                                                                                                                                                                    | \$5,680,000    |                                               |                                                         | 105                         |





Office of the City Manager

CONSENT CALENDAR

April 23, 2019

To: Honorable Mayor and Members of the City Council

From: Dee Williams-Ridley, City Manager

Submitted by: Savita Chaudhary, Director, Department of Information Technology

Subject: Purchase Orders for Crayon Inc.: Using Riverside County's Joint Volume Licensing Program to Renew Microsoft's Enterprise Agreement

RECOMMENDATION

Adopt a Resolution authorizing the City Manager to execute a three-year renewal of the City's "Enterprise Agreement" (EA) for Microsoft licenses purchased through Crayon Inc., utilizing a cooperative purchasing agreement established by the County of Riverside's joint volume licensing program for the period beginning May 1, 2019 through April 30, 2022 for an amount not-to-exceed (NTE) \$2,968,000.

FISCAL IMPACTS OF RECOMMENDATION

Funding for the three-year agreement is Fiscal Year (FY) 2019 is available in the Department of Information Technology's Cost Allocation, General Fund, and Capital Improvement funds as outlined below. Funding in future years will be available in the Department of Information Technology's FY 2020 and 2021 IT Cost Allocation budget, and is subject to Council approval of the proposed city-wide budget and Annual Appropriation Ordinances. The total cost of the three year agreement is \$2,968,000.

**Summary: FY 2019-2021**

\$864,000 Year 1: FY 2019  
 \$1,052,000 Year 2: FY 2020  
 \$1,052,000 Year 3: FY 2021

---

**\$2,968,000 Total FY 2019-2021: Software Maintenance**

**Year 1: FY 2019**

\$511,536 FY 2019: Software Maintenance  
 Budget Code: 680-35-362-376-0000-000-472-613130-  
 (IT Cost Allocation, Enterprise Applications, Software Maintenance)

\$307,464 FY 2019: Software Maintenance  
 Budget Code: 011-35-362-376-0000-000-412-613130-  
 (General Fund, Information Technology, Software Maintenance)

\$45,000 FY 2019: Software Maintenance  
 Budget Code: 501-35-362-376-0000-000-412-612990-  
 (Capital Improvement, Information Technology, Software Maintenance)

---

---

\$864,000 Total FY 2019 Software Maintenance

**Year 2: FY 2020**

FY 2020: Software Maintenance

\$1,052,000 Budget Code: 680-35-362-376-0000-000-472-613130-  
(IT Cost Allocation, Enterprise Applications, Software Maintenance)

---

\$1,052,000 Total FY 2020 Software Maintenance

**Year 3: FY 2021**

FY 2021: Software Maintenance

\$1,052,000 Budget Code: 680-35-362-376-0000-000-472-613130-  
(IT Cost Allocation, Enterprise Applications, Software Maintenance)

---

\$1,052,000 Total FY 2021 Software Maintenance

**CURRENT SITUATION AND ITS EFFECTS**

The City's core software infrastructure is based on Microsoft desktop, server, collaboration, and development products. The EA positions the City to benefit from the next generation of Microsoft platform products seamlessly through ownership of Software Assurance. Specifically, this agreement ensures that the City has access to the latest version of software and that technical support is available. This reduces the required level of staff to support the Microsoft platform, and also enables software upgrade decisions to be made based on technical considerations, deployment plans, and staffing availability, rather than primarily cost considerations. The City's current agreement term expires April 30, 2019. The term of this agreement is three years, and the price of these licenses remains constant throughout the term of the agreement which assists in financial planning of future years. The maximum term available for the EA is three years.

These agreements have saved the City money through volume purchasing and greatly simplified licensing by requiring a single transaction to acquire licenses for the City. This agreement includes software assurance which will provide the City with the legal right to continue to receive the current version of Microsoft products used by the City, including our MS Office suite of products, Office 365, Skype for Business, Exchange Server, SharePoint Server, Windows Servers, and SQL Servers. The agreement also offers training vouchers and an e-learning self-service platform for the end users to learn the Office products.

Indicative costs for the renewal of the Microsoft EA and Software Assurance include 10% contingency. Each year Department of Information Technology undertake a 'true up' (increase) or 'true down' (decrease) exercise with the reseller to ensure that the City's licensing reflects actual need and takes account of any changes that have occurred in that year. This will continue to be the case for the life of the new three years contract.

Also, more products and services become automatically available within the EA. Examples of such software products are SharePoint Portal Services (SPS), a

collaboration-based web portal product, and System Center, a product which automates deployments, and allows for remote desktop support.

As part of its technology procurement practices, the City typically upgrades and deploys core City software in a timeframe that keeps the versions at, or near, current commercial release versions. Participating in an EA is necessary to ensure critical systems are kept current with security-related and product feature improvements.

### BACKGROUND

The City of Berkeley uses Microsoft products as its standardized computer software at the server and workstation level. The City purchases Microsoft software licenses through a joint, volume licensing program known as the County of Riverside's Microsoft Enterprise Agreement ('Riverside EA'). Typically Microsoft offers government EA customers' volume discounts in four tiers A-D. Tier D is reserved for very large enterprises which have over 150,000 workstations. Under the Riverside EA Agreement we will receive pricing that is 7.5% lower than Tier "D" pricing which represents a significant savings from what a City of our size would normally be charged, during this agreement period.

The Riverside EA is a cooperative purchasing program which was renegotiated in 2016 through a Request for Qualifications (RFQ) No. PUARC-1518, by the County of Riverside, and continues to be the primary procurement vehicle for Microsoft licenses for many government agencies throughout California. Riverside County's RFQ also awarded Participating Agreements to seven additional Licensing Solutions Providers (LSPs) which are available for use by government agencies within the State of California.

### ENVIRONMENTAL SUSTAINABILITY

Upgrades to server software licensing allow for the consolidation of servers and increased storage capacity to storage area networks (SANs) and cloud storage with products such as Microsoft's cloud storage product OneDrive. This move increases the City's goal of reducing energy consumption City buildings and maintaining an environmentally sound information technology infrastructure.

### RATIONALE FOR RECOMMENDATION

Using cooperative purchasing agreements significantly improves the quality of purchasing executed by the City, and participation in such agreements allows the City to gain greater efficiencies and economies of scale. Microsoft will as of 11/1/2019 at the start of the new Riverside and State of California contract's Microsoft will be removing the Level D -7.5% and every customer will be purchasing at straight Level D. Microsoft will no longer be offering the 7.5% discount, this is due to other states legal action of not being offered the same discount as states like California. By entering into an EA with Microsoft at this time protects the City from price increases that Microsoft will put into place during the term of the three-year agreement.

ALTERNATIVE ACTIONS CONSIDERED

Microsoft does not license its software directly, but instead requires licensing of its products through a reseller. Staff considered issuing a specific bid for the renewal of the City's Microsoft EA, but at this time, doing so would not yield better pricing than that which is currently established through the Riverside EA.

CONTACT PERSON

Savita Chaudhary, Director, Information Technology, 510-981-6525

Attachments:

1: Resolution

RESOLUTION NO. ##,###-N.S.

PURCHASE ORDERS FOR CRAYON, INC.: USING THE RIVERSIDE COUNTY'S JOINT VOLUME LICENSING PROGRAM TO RENEW MICROSOFT'S ENTERPRISE AGREEMENT

WHEREAS, the City of Berkeley's core software infrastructure is based on Microsoft desktop, server, and development products, and Microsoft does not license its software directly, but instead requires licensing of its products through a reseller; and

WHEREAS, by utilizing cooperative purchasing agreements such as the Riverside Enterprise Agreement, 'the Riverside EA', the City of Berkeley is able to take advantage of pre-negotiated prices, economies of scale, and increased efficiencies; and

WHEREAS, known as the 'Riverside EA', the cooperative purchasing program was re-negotiated in 2016 through a Request for Qualifications (RFQ) No. PUARC-1518, by the County of Riverside, and continues to be the primary procurement vehicle for Microsoft licenses for many government agencies throughout California; and

WHEREAS, cooperative purchasing agreements significantly improve the quality of purchasing executed by the City, and participation in such agreements allows the City to gain greater efficiencies and economies of scale, and entering into an EA with Microsoft protects the City from price increases that Microsoft will put into place during the term of the three-year agreement; and

WHEREAS, funding for Fiscal Year (FY) 2019 is available in the Department of Information Technology's Cost Allocation, General Fund, and Capital Improvement Funds, and spending in future years will be available in the Department of Information Technology's FY 2020 and 2021 IT Cost Allocation budget as itemized below, and is subject to Council approval of the proposed city-wide budget and Annual Appropriation Ordinances.

NOW THEREFORE, BE IT RESOLVED by the Council of the City of Berkeley that the City Manager is authorized to issue purchase orders with Crayon Inc. for the renewal of the City's Microsoft Enterprise Agreement licenses, utilizing a cooperative purchasing agreement established by the County of Riverside's joint volume licensing program, for the period beginning May 1, 2019 through April 30, 2022 for an amount not-to-exceed (NTE) \$2,968,000.







Office of the City Manager

CONSENT CALENDAR  
April 23, 2019

To: Honorable Mayor and Members of the City Council  
From: Dee Williams-Ridley, City Manager  
Submitted by: Savita Chaudhary, Director, Information Technology  
Subject: Contract No. 118499-1 Amendment: Civic Makers, LLC for FUND\$ Replacement Change Management Support Services

RECOMMENDATION

Adopt a Resolution authorizing the City Manager to amend Contract No. 118499-1 with Civic Makers, LLC for extension of FUND\$ Replacement related Change Management Support Services, increasing the amount by \$400,000, for a total not to exceed \$529,025 from December 1, 2017 to June 30, 2021.

FISCAL IMPACTS OF RECOMMENDATION

Funds for the additional scope of work in the amount of \$400,000 are allocated in the Department of Information Technology’s Fiscal Year (FY) 2019 FUND\$ Replacement Fund as follows:

|           |                                                                                                                                                                                |
|-----------|--------------------------------------------------------------------------------------------------------------------------------------------------------------------------------|
| \$400,000 | Change Management and user adoption Services<br>FY 2019 Budget Code: 503-35-362-376-0000-000-412-612990<br>(FUND\$ Replacement, Information Technology, Professional Services) |
| <hr/>     |                                                                                                                                                                                |
| \$400,000 | Total additional Professional Services                                                                                                                                         |

CURRENT SITUATION AND ITS EFFECTS

Civic Makers was retained through a competitive process to provide change management support to the Change Management Team for the replacement of FUND\$ and adoption of Tyler-Munis. Civic Makers provides professional training and support to staff to assist staff in leading the agency through replacing FUND\$ and Tyler-Munis implementation.

The City has identified additional needs to support the change management initiative as well as develop and implement a thorough training plan for payroll and human resources implementation phases. This includes communication services, development of training materials, development of comprehensive and department specific training for payroll, creating materials that resonate with staff to address questions and business processes and support change management with specific action items to support adoption of the new ERP.

BACKGROUND

Civic Makers has been working with the City FUND\$ Replacement team and has a deep understanding of City culture and needs for change management. The team has identified the need for additional services in addition to original scope which was limited to training and general assistance to incorporate specific services and an action plan to change management.

ENVIRONMENTAL SUSTAINABILITY

Civic Makers will work with the City to ensure solutions are as eco-friendly as possible. Only necessary copies will be printed, most solutions will be delivered electronically

RATIONALE FOR RECOMMENDATION

As we implement additional modules in Phase 2 and 3 of the FUND\$ replacement after erma (ERP – Tyler Munis), post go live adoption is a key to success for the City and the team is committed to incorporating lessons learned from prior implementations. Civic Makers specializes in user adoption. The City will benefit from expert input, coaching, and guidance through the process.

ALTERNATIVE ACTIONS CONSIDERED

Staff considered alternate services and explored internal and external resources. It was determined that Civic Makers expertise is the best fit for the City.

CONTACT PERSON

Savita Chaudhary, Director, Information Technology, 510-981-6541

Attachments:

1: Resolution

RESOLUTION NO. ##,###-N.S.

CONTRACT NO. 118499-1 AMENDMENT: CIVIC MAKERS, LLC FOR FUND\$  
REPLACEMENT CHANGE MANAGEMENT SUPPORT SERVICES

WHEREAS, Civic Makers entered into a contract with the City in December, 2017 to support change management services for FUND\$ Replacement initiative; and

WHEREAS, Civic Makers is a local expert in Change Management and maintains a positive relationship with the Change Management Team; and

WHEREAS, Civic Makers has an established relationship with the City of Berkeley's erma team and has a deep understanding of City culture and needs for change management and training, and the team has identified the need for additional services in addition to original scope which was limited to training and general assistance to incorporate specific services and an action plan to change management; and

WHEREAS, one-time funding for additional change management and training services is allocated in the Department of Information Technology's FY 2019 FUND\$ Replacement fund.

NOW THEREFORE, BE IT RESOLVED by the Council of the City of Berkeley that the City Manager is authorized to amend Contract No. 118499-1 with Civic Makers for FUND\$ Replacement Change Management Support Services, increasing the amount by \$400,000 for a total contract amount not to exceed \$529,095, for the term December 1, 2017 to June 30, 2021.





Office of the City Manager

CONSENT CALENDAR

April 23, 2019

To: Honorable Mayor and Members of the City Council

From: Dee Williams-Ridley, City Manager

Submitted by: Scott Ferris, Director, Parks Recreation & Waterfront

Subject: Donation: Memorial Bench at Cesar Chavez Park in memory of Julio Costa Furtado

RECOMMENDATION

Adopt a Resolution accepting a cash donation in the amount of \$3,400 for a memorial bench to be placed at Cesar Chavez Park at the Berkeley Marina in memory of Julio Costa Furtado.

FISCAL IMPACTS OF RECOMMENDATION

The value of a single bench and memorial plaque is \$3,400, which covers the purchasing and installation costs performed by the City. The cash donation will be deposited into Marina Fund donation revenue budget code 825-5902-368-2001 and will be appropriated in FY 2019.

CURRENT SITUATION AND ITS EFFECTS

The family of Julio Costa Furtado wishes to donate a memorial bench in his memory to be placed at Cesar Chavez Park at the Berkeley Marina with a cash donation of \$3,400. Per the City's Park Bench Donation Policy, individuals may donate memorial benches to the City's parks in selected locations, subject to the approval of the Director of the Parks Recreation & Waterfront Department, and pay for all associated costs, subject to Council disclosure and approval of the gift donation. The Director has determined that the proposed donation complies with the City's Bench Donation Policy as described in Resolution No. 64,148-N.S. and has approved the donation, subject to Council approval.

BACKGROUND

Benches are placed throughout the City in accordance with the City's Park Bench Donation Policy approved by Council on July 22, 2008 (Resolution No. 64,148-N.S.). The City's Open Governance Ordinance (OGO) requires City Council disclosure and approval of any gift to the City in excess of \$1,000 (BMC Section 2.06.150, Ord. 7,166-N.S.)

ENVIRONMENTAL SUSTAINABILITY

The City's vendor for benches, Dumor, Inc. makes its priority to purchase only sustainably-harvested wood derived from stringently-regulated timber source locations, including California, Oregon, Washington and British Columbia. This policy reduces solid waste volumes in landfills, helps conserve natural resources and limits the environmental effects resulting from the extraction of virgin materials. The benches therefore comply with the City's environmentally preferable purchasing policy, specifically section 3.7 Forest Conservation.

CONTACT PERSON

Alexandra Endress, Waterfront Manager, 981-6737

Attachments:

1: Resolution

RESOLUTION NO. ##,###-N.S.

DONATION: MEMORIAL BENCH AT CESAR CHAVEZ PARK AT THE BERKELEY MARINA IN MEMORY OF JULIO COSTA FURTADO

WHEREAS, on July 22, 2008, Council adopted the Park Bench Donation Policy (Resolution No. 64,148-N.S.); and

WHEREAS, the City's Open Governance Ordinance (OGO) requires City Council disclosure and approval of any gift to the City in excess of \$1,000 (BMC Section 2.06.150, Ord. 7,166-N.S.); and

WHEREAS, the family of Julio Costa Furtado wishes to donate a memorial bench in his memory to be placed at Cesar Chavez Park at the Berkeley Marina with a cash donation of \$3,400; and

WHEREAS, per the City's Park Bench Donation Policy, individuals may donate memorial benches to the City's parks in selected locations, subject to the approval of the Director of the Parks Recreation & Waterfront Department, and pay for all associated costs, subject to Council disclosure and approval of the gift donation; and

WHEREAS, the Director has determined that the proposed donation complies with City's Bench Donation Policy as described in Resolution No. 64,148-N.S. and has approved the proposed donation; and

WHEREAS, the cash donation will be deposited into Marina Fund donation revenue budget code 825-5902-368-2001.

NOW THEREFORE, BE IT RESOLVED by the Council of the City of Berkeley that a cash donation in the amount of \$3,400 for a memorial bench to be placed at Cesar Chavez Park at the Berkeley Marina in memory of Julio Costa Furtado is hereby accepted.







Office of the City Manager

CONSENT CALENDAR

April 23, 2019

To: Honorable Mayor and Members of the City Council

From: Dee Williams-Ridley, City Manager

Submitted by: Scott Ferris, Director, Parks Recreation & Waterfront

Subject: Donation: Memorial Bench at Cesar Chavez Park in memory of Barry Wofsy

RECOMMENDATION

Adopt a Resolution accepting a cash donation in the amount of \$3,400 for a memorial bench to be placed at Cesar Chavez Park at the Berkeley Marina in memory of Barry Wofsy.

FISCAL IMPACTS OF RECOMMENDATION

The value of a single bench and memorial plaque is \$3,400, which covers the purchasing and installation costs performed by the City. The cash donation will be deposited into Marina Fund donation revenue budget code 825-5902-368-2001 and will be appropriated in FY 2019.

CURRENT SITUATION AND ITS EFFECTS

The family of Barry Wofsy wishes to donate a memorial bench in his memory to be placed at Cesar Chavez Park at the Berkeley Marina with a cash donation of \$3,400. Per the City's Park Bench Donation Policy, individuals may donate memorial benches to the City's parks in selected locations, subject to the approval of the Director of the Parks Recreation & Waterfront Department, and pay for all associated costs, subject to Council disclosure and approval of the gift donation. The Director has determined that the proposed donation complies with the City's Bench Donation Policy as described in Resolution No. 64,148-N.S. and has approved the donation, subject to Council approval.

BACKGROUND

Benches are placed throughout the City in accordance with the City's Park Bench Donation Policy approved by Council on July 22, 2008 (Resolution No. 64,148-N.S.). The City's Open Governance Ordinance (OGO) requires City Council disclosure and approval of any gift to the City in excess of \$1,000 (BMC Section 2.06.150, Ord. 7,166-N.S.)

ENVIRONMENTAL SUSTAINABILITY

The City's vendor for benches, Dumor, Inc. makes its priority to purchase only sustainably-harvested wood derived from stringently-regulated timber source locations, including California, Oregon, Washington and British Columbia. This policy reduces solid waste volumes in landfills, helps conserve natural resources and limits the environmental effects resulting from the extraction of virgin materials. The benches therefore comply with the City's environmentally preferable purchasing policy, specifically section 3.7 Forest Conservation.

CONTACT PERSON

Alexandra Endress, Waterfront Manager, 981-6737

Attachments:

1: Resolution

RESOLUTION NO. ##,###-N.S.

DONATION: MEMORIAL BENCH AT CESAR CHAVEZ PARK AT THE BERKELEY MARINA IN MEMORY OF BARRY WOFSY

WHEREAS, on July 22, 2008, Council adopted the Park Bench Donation Policy (Resolution No. 64,148-N.S.); and

WHEREAS, the City's Open Governance Ordinance (OGO) requires City Council disclosure and approval of any gift to the City in excess of \$1,000 (BMC Section 2.06.150, Ord. 7,166-N.S.); and

WHEREAS, the family of Barry Wofsy wishes to donate a memorial bench in his memory to be placed at Cesar Chavez Park at the Berkeley Marina with a cash donation of \$3,400; and

WHEREAS, per the City's Park Bench Donation Policy, individuals may donate memorial benches to the City's parks in selected locations, subject to the approval of the Director of the Parks Recreation & Waterfront Department, and pay for all associated costs, subject to Council disclosure and approval of the gift donation; and

WHEREAS, the Director has determined that the proposed donation complies with City's Bench Donation Policy as described in Resolution No. 64,148-N.S. and has approved the proposed donation; and

WHEREAS, the cash donation will be deposited into Marina Fund donation revenue budget code 825-5902-368-2001.

NOW THEREFORE, BE IT RESOLVED by the Council of the City of Berkeley that a cash donation in the amount of \$3,400 for a memorial bench to be placed at Cesar Chavez Park at the Berkeley Marina in memory of Barry Wofsy is hereby accepted.





Office of the City Manager

CONSENT CALENDAR

April 23, 2019

To: Honorable Mayor and Members of the City Council  
 From: Dee Williams-Ridley, City Manager  
 Submitted by: Scott Ferris, Director, Parks Recreation & Waterfront  
 Subject: Donation: Information Display Case at the Berkeley Rose Garden

RECOMMENDATION

Adopt a Resolution accepting a donation of an information display case valued at \$7,429 from the Friends of the Berkeley Rose Garden.

FISCAL IMPACTS OF RECOMMENDATION

The Friends of the Berkeley Rose Garden have raised funds in the amount of \$7,429 to obtain an information display case to be installed at the Berkeley Rose Garden. The case will be delivered to the City's Corporation Yard and will be installed by City staff at the Rose Garden.

CURRENT SITUATION AND ITS EFFECTS

The Friends of the Berkeley Rose Garden have raised funds to obtain a redwood information display case that was designed and constructed by Berkeley Mills Furniture and Cabinetry. The case will enable historic information and notices of activities to be posted in an attractive manner consistent with the aesthetics of the Berkeley Rose Garden. The Friends were able to make this offer thanks to donations from throughout the community from those who love the Garden, one of the City's civic treasures.

BACKGROUND

The City's Open Governance Ordinance (OGO) requires City Council disclosure and approval of any gift to the City in excess of \$1,000 (BMC Section 2.06.150, Ord. 7,166-N.S.)

ENVIRONMENTAL SUSTAINABILITY

The informational display case will be constructed by Berkeley Mills Furniture and Cabinetry, a local vendor. Berkeley Mills is committed to ecologically sound manufacturing and business practices. Because wood is the heart of their business, Berkeley Mills does everything possible to support sustainable forestry and the responsible use of this precious resource. This policy is consistent with the City's environmentally preferable purchasing policy, specifically section 3.7 Forest Conservation.

Donation: Information Display Case at the Berkeley Rose Garden

CONSENT CALENDAR  
April 23, 2019

CONTACT PERSON

Scott Ferris, Director, Parks, Recreation & Waterfront, 981-6700.

Attachments:

1: Resolution

Exhibit A: Letter from Friends of the Berkeley Rose Garden

RESOLUTION NO. ##,###-N.S.

DONATION: INFORMATIONAL DISPLAY CASE FROM THE FRIENDS OF THE  
BERKELEY ROSE GARDEN

WHEREAS, the City's Open Governance Ordinance (OGO) requires City Council disclosure and approval of any gift to the City in excess of \$1,000 (BMC Section 2.06.150, Ord. 7,166-N.S.); and

WHEREAS, the Friends of the Berkeley Rose Garden have purchased a redwood information display case that was designed and constructed by Berkeley Mills Furniture and Cabinetry for the cost of \$7,429; and

WHEREAS, the case will enable historic information and notices of activities to be posted in an attractive manner consistent with the aesthetics of the Berkeley Rose Garden; and

WHEREAS, the Friends were able to make this offer thanks to donations from throughout the community from those who love the Garden, one of the City's civic treasures.

NOW THEREFORE, BE IT RESOLVED by the Council of the City of Berkeley that the donation of an information display case valued at \$7,429 from the Friends of the Berkeley Rose Garden (Exhibit A) is hereby accepted.

Attachments:

Exhibit A: from Friends of the Berkeley Rose Garden



March 7, 2019

Mayor Arreguin & Members of the Berkeley City Council  
City of Berkeley  
2180 Milvia Street  
Berkeley, CA 94707

cc: Scott Ferris  
Director of Parks, Recreation & Waterfront  
& Miguel Cortes, Rosarian

Subject: Offer to donate an information display case/kiosk for the Berkeley Rose Garden to the City of Berkeley

Dear Mayor Arreguin and Members of the City Council,

Friends of the Berkeley Rose Garden, a volunteer group committed to the celebration, support and enhancement of our City's wonderful Municipal Rose Garden, is pleased to offer to donate to the City of Berkeley a redwood information display case ("kiosk") designed and being constructed by Berkeley Mills.

The kiosk will enable historic information and notices of activities to be posted in an attractive manner consistent with the aesthetic of the Garden.

A drawing of the kiosk is attached. We have coordinated with Scott Ferris in its design. The City Department of Parks and Recreation will determine where to site it. Berkeley Mills generously gave us a discount of \$1000. The Friends will pay the attached invoice for \$6800 plus \$629 tax for a total of \$7429.

We are able to make this offer thanks to donations from throughout the community from those who love the Garden, one of our civic treasures.

We appreciate the City's ongoing commitment to the restoration of the Garden.

Sincerely,

A handwritten signature in cursive script that reads "C. B. Leland".

Catherine "Kit" Leland  
For Friends of the Berkeley Rose Garden



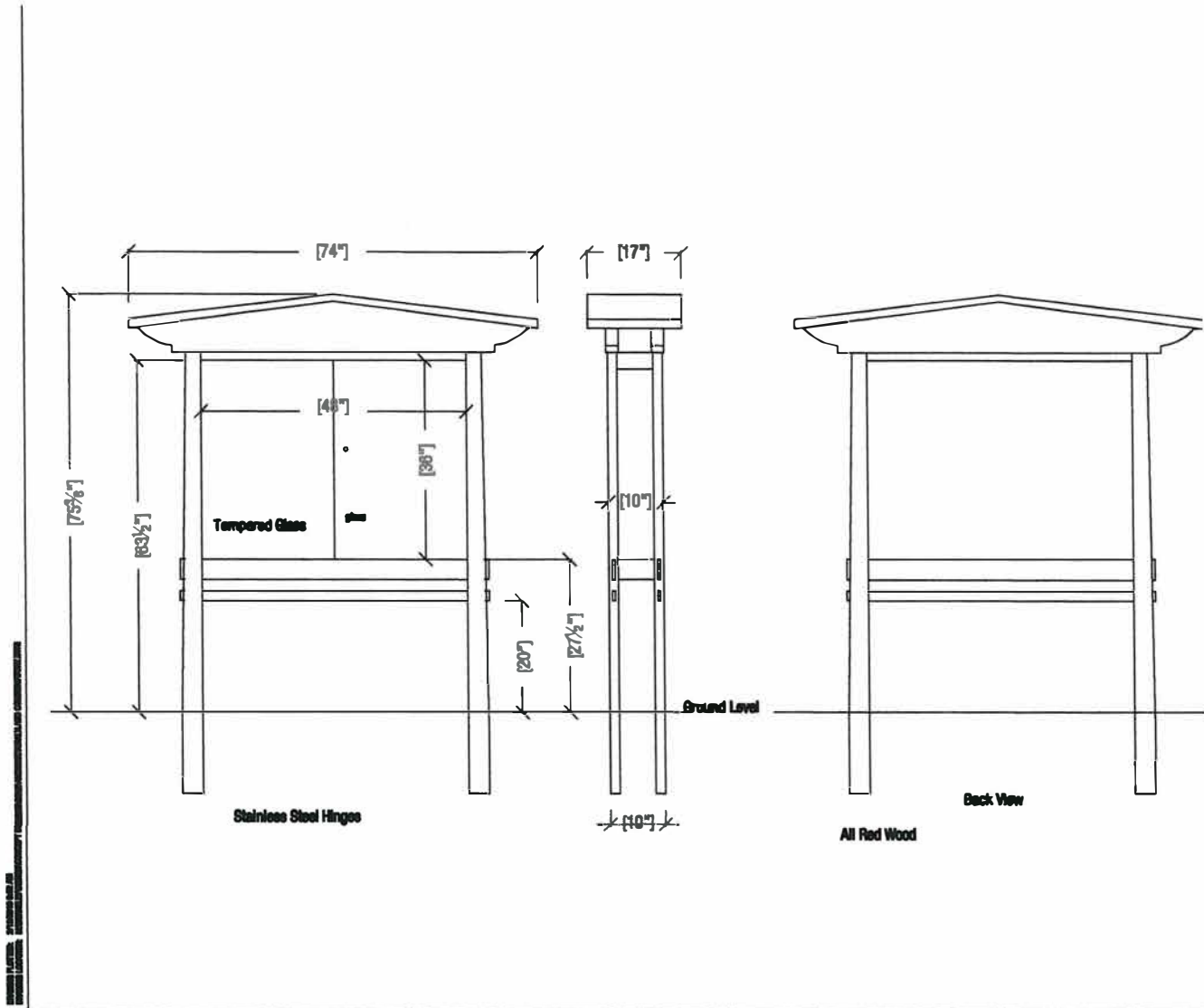

|             |                           |
|-------------|---------------------------|
| CLASS       | High Street               |
| DESCRIPTION | BENCH                     |
| QUANTITY    | 1                         |
| DATE        | 04/15/2014                |
| FILE        | LAND CONSTRUCTION 4/14/14 |
| SCALE       | 1"=4'-0"                  |

| COMPONENT    | QUANTITY |
|--------------|----------|
| FRAME        |          |
| SEWER PANELS |          |
| DOOR PANELS  |          |
| SEWER PANEL  |          |
| SCREENS      |          |
| GLASS        |          |
| OTHER        |          |

NOTES:  
RED WOOD

APPROVED FOR CONSTRUCTION (DATE) \_\_\_\_\_

APPROVED FOR ARCHITECTURAL (DATE) \_\_\_\_\_

**TERMS AND CONDITIONS**  
All designs © 2014 Berkeley Mills & Furniture Co., Inc. Drawings remain the property of B.M.F. They may not be copied, altered or distributed to others in any manner by any method without written approval from Berkeley Mills. Customers will be liable for attorney's fees, and damages resulting from breach of this provision. If the design project is not completed by Berkeley Mills, all designs and drawings provided must be returned within 10 days.

  
**Berkeley Mills**  
 outdoor furniture design®  
 3800 7TH STREET BERKELEY CA 94710  
 TEL. 925.842.2824 | FAX 925.842.2825

11





Office of the City Manager

CONSENT CALENDER  
April 23, 2019

To: Honorable Mayor and Members of the City Council  
 From: Dee Williams-Ridley, City Manager  
 Submitted by: Scott Ferris, Director, Parks Recreation & Waterfront  
 Subject: Grant Application: Cosco Busan Round 2 Grant Program from the National Fish and Wildlife Foundation

RECOMMENDATION

Adopt a Resolution authorizing the City Manager or her designee to: submit a grant application in the amount of \$182,000 to the National Fish and Wildlife Foundation for the Cosco Busan Round 2 Grant Program; accept any grants; execute any resulting grant agreements and any amendments; and that Council authorize the implementation of the project and appropriation of funding for related expenses, subject to securing the grant.

FISCAL IMPACTS OF RECOMMENDATION

The Cosco Busan Grant Program administered by the National Fish and Wildlife Foundation does not require local matching funds. However, the City has already programmed and funded several projects at the South Cove in the approved FY 2019 budget at the Berkeley Marina that can be included as match in order to submit a competitive proposal. If awarded in the Fall of 2019, the grant funds will be appropriated as part of the First Amendment to the FY 2020 Annual Appropriations Ordinance.

CURRENT SITUATION AND ITS EFFECTS

In January 2019, the National Fish and Wildlife Foundation announced the availability of grant funding for Round 2 of the Cosco Busan Grant Program for cities affected by the oil spill of 2007 to allocate the remaining funds that were not spent in Round 1 of the grant program. Up to \$400,000 in grant funding will be available for competitive proposals from East Bay cities.

The City will submit a grant application to renovate the existing Boat Hoist Staging Area at the South Cove at the Berkeley Marina. This will involve re-paving the existing Staging Area at the boat hoists with new traffic and pedestrian striping; installing an ADA accessible path-of-travel linking the new Accessible Ramp to the Bay Trail; replacing the existing water line to the Boat Hoists; and replacing the existing Boat Hoists (2).

The City has already programmed and funded the following projects at the Boat Dock Staging Area at the South Cove in the approved FY2019 Budget, and will use these as matching funds for the Cosco Busan grant application:

- a) Installation of a new ADA accessible ramp and landing dock and abutment at the existing Middle Dock (\$125,400 from the ABAG Water Trail Grant and \$120,000 from the Marina Fund).
- b) Replacement of two existing small boat docks (east and west) (completion scheduled for 2019). (\$113,000 from the Marina Fund).
- c) Installation of segment 3 of the Bay Trail to link the South Cove Parking Lot to the Adventure Playground (completion scheduled for 2019) (\$500,000 from the Metropolitan Transportation Commission (Caltrans funding) and \$216,000 from the Marina Fund).

This work is part of the City's overall effort to upgrade the aging infrastructure at the Berkeley Waterfront. For example, in the Fall of 2018, the City completed the South Cove Parking Lot and New Public Restroom, funded 66% by grants and 34% by the Marina Fund. In the Fall of 2020, the City is planning to complete a renovation of the three major roadway segments at the Berkeley Marina: University Ave; Marina Blvd; and Spinnaker Way, which will be funded primarily by the Measure T1 Infrastructure Program.

#### BACKGROUND

On November 6, 2007, the container ship Cosco Busan caused an oil spill in the San Francisco Bay that affected the shoreline and habitats throughout the entire Bay Area. On March 26, 2012, the National Fish and Wildlife Foundation, together with the California Department of Fish and Game (CDFG) and the California State Lands Commission (CSLC), conducted Round 1 of the Cosco Busan Grant Program and allocated \$6.8 million in competitive grants for recreational projects related to the waters of the San Francisco Bay that compensate the public for the loss of use and enjoyment of public beaches, parks, and other public or natural resources as a result of the oil spill. In January 2019, the National Fish and Wildlife Foundation announced Round 2 of the Cosco Busan Grant Program to allocate the remaining \$1 million in funds that were not spent in Round 1 of the program. Approximately \$400,000 in grant funds will be available for East Bay cities.

#### ENVIRONMENTAL SUSTAINABILITY

The Boat Dock Staging Area at the South Cove at the Berkeley Marina provides access to the waters of the San Francisco Bay to thousands of windsurfers, kayakers, canoes, stand-up paddle boards (SUPs), swimmers, and nature watchers. These activities promote active stewardship of the Bay and greater direct awareness of sea level rise and the goals of Chapter Six – Adapting to a Changing Climate – in the City's Climate Action Plan.

#### RATIONALE FOR RECOMMENDATION

The South Cove Boat Dock Staging Area is currently comprised of a severely degraded asphalt and gravel surface with poor road striping for proper traffic and pedestrian

management. It is a highly congested area with multiple conflicting paths of travel, multiple tripping hazards, and no dedicated accessible path of travel to the new accessible ramp at the middle dock. In the proposed project, a new asphalt and striped surface at the Boat Dock Staging Area will greatly improve the safety and accessibility of the public use of the Bay Trail, the public sailing clubs, the public docks, and access to the Bay waters.

CONTACT PERSON

Scott Ferris, Director, Parks, Recreation & Waterfront Department, 981-6700  
Roger Miller, Senior Management Analyst, 981-6704

Attachments:

1: Resolution

RESOLUTION NO. ##,###-N.S

GRANT APPLICATION: COSCO BUSAN ROUND 2 GRANT PROGRAM FROM THE NATIONAL FISH AND WILDLIFE FOUNDATION FOR THE SOUTH COVE BOAT DOCK STAGING AREA IN THE AMOUNT OF \$182,000

WHEREAS, on November 6, 2007, the container ship Cosco Busan caused an oil spill in the San Francisco Bay that affected the shoreline and habitats throughout the entire Bay Area; and

WHEREAS, on November 6, 2007, the container ship Cosco Busan caused an oil spill in the San Francisco Bay that affected the shoreline and habitats throughout the entire Bay Area; and

WHEREAS, on March 26, 2012, the National Fish and Wildlife Foundation, together with the California Department of Fish and Game (CDFG) and the California State Lands Commission (CSLC), conducted Round 1 of the Cosco Busan Grant Program and allocated \$6.8 million in competitive grants for recreational projects related to the waters of the San Francisco Bay that compensate the public for the loss of use and enjoyment of public beaches, parks, and other public or natural resources as a result of the oil spill; and

WHEREAS, in January 2019, the National Fish and Wildlife Foundation announced Round 2 of the Cosco Busan Grant Program to allocate the remaining \$1 million in funds that were not spent in Round 1 of the program. Approximately \$400,000 in grant funds will be available for East Bay cities; and

WHEREAS, the Cosco Busan Grant Program administered by the National Fish and Wildlife Foundation does not require local matching funds. However, the City has already programmed and funded several projects at the South Cove in the approved FY 2019 budget at the Berkeley Marina that can be included as match in order to submit a competitive proposal. If awarded in the Fall of 2019, the grant funds will be appropriated as part of the First Amendment to the FY 2020 Annual Appropriations Ordinance.

NOW THEREFORE, BE IT RESOLVED by the Council of the City of Berkeley that the City Manager or her designee is authorized to: submit a grant application in the amount of \$182,000 to the National Fish and Wildlife Foundation for the Cosco Busan Round 2 Grant Program; accept any grants; execute any resulting grant agreements and any amendments; and that Council authorize the implementation of the project and appropriation of funding for related expenses, subject to securing the grant. A record signature copy of said agreements and any amendments to be on file in the Office of the City Clerk.



Office of the City Manager

CONSENT CALENDAR  
April 23, 2019

To: Honorable Mayor and Members of the City Council

From: Dee Williams-Ridley, City Manager

Submitted by: Andrew Greenwood, Chief of Police

Subject: Contract No. 9668 Amendment: Serological Research Institute for DNA Testing Services

RECOMMENDATION

Adopt a Resolution authorizing the City Manager to amend Contract No. 9668 and any necessary future amendments with Serological Research Institute (SERI) for the Police Department, increasing the contract amount by \$250,000 for a total not to exceed amount of \$750,000 and a contract term extension for three additional years until June 30, 2022.

FISCAL IMPACTS OF RECOMMENDATION

Approval of the recommendation would support an ongoing operational expense required for solving criminal cases in a timely manner. The funding for this contract is allocated from the State Proposition 172 Fund (budget code 126-71-702-805-0000-000-421-612990). If annual usage exceeds the available budget in the State Proposition 172 Fund, the General Fund would be necessary to augment the support budget for these essential services.

CURRENT SITUATION AND ITS EFFECTS

The Berkeley Police Department currently contracts with the Serological Research Institute (SERI) for its forensic deoxyribonucleic acid (DNA) testing services. It can be difficult to estimate the dollar amount required annually as it can change significantly from year to year. For FY 2019, the Department will exceed the current \$500,000 contract limits set when this contract was originally established in 2014. This dollar increase and time extension will allow the Department to continue to test DNA for criminal investigations. This enables the potential identification of a suspect based on DNA found at a crime scene and may result in the suspect being arrested and charged faster.

Due to the unpredictable nature of the contract usage, the BPD has expended over \$150,000 this fiscal year through March and has only \$4,000 remaining of the original \$500,000 contract. In order to continue processing DNA evidence to substantiate charges against suspects, the BPD is requesting this contract amendment.

### BACKGROUND

In 2014, the Department entered into a service contract with SERI to obtain their forensic DNA services. SERI was added when two other providers, the Alameda County Sheriff's Crime Laboratory and Forensic Analytical Sciences, Inc. were unable to keep up with increased caseload from the Berkeley Police Department. SERI is accredited through the American Society of Crime Laboratories Directors/Laboratory Accreditation Board. SERI is located in Richmond, CA and provides state of the art forensic services, laboratory analysis and expert testimony for its clients.

While maintaining compliance with the Federal Bureau of Investigations, Quality Assurance Standards for Forensic DNA Testing, SERI has consistently provided the fastest case turnaround times of our three contracted vendors. SERI has helped minimize DNA testing backlogs the department was experiencing with other vendors. Fast DNA testing turnaround times help the department identify serious violent offenders and helps solve criminal cases faster. SERI was originally intended to be an additional DNA Laboratory. However, due to the high level of service provided, they have become our primary provider. During this time, the investigative demand for their services has increased based on several factors including improved DNA recovery techniques and new legislative requirements.

### ENVIRONMENTAL SUSTAINABILITY

Serological Research Institute provides and maintains an extensive online test request submission and products ordering option. These online forms reduce the amount of paper required to forward and process requests.

### RATIONALE FOR RECOMMENDATION

The cost associated with DNA testing services is an operational expense for which the Berkeley Police Department is currently responsible. In an effort to solve criminal cases as fast as practical and potentially limit further victimization, the BPD continues to utilize these services. An amendment to increase funds and extend the contract will allow the Department to continue to meet the DNA testing requirements of its investigations.

### CONTACT PERSON

Andrew Greenwood, Chief of Police, 981-5700

Attachment:

1. Resolution



RESOLUTION NO. ##,###-N.S.

CONTRACT NUMBER 9668 AMENDMENT FOR SEROLOGICAL RESEARCH  
INSTITUTE FOR DNA TESTING SERVICES

WHEREAS, the Berkeley Police Department is responsible for the investigation of criminal cases in Berkeley; and

WHEREAS, closure of criminal investigations will bring relief to the families of the victims and reduce fear in the community; and

WHEREAS, the use of forensic deoxyribonucleic acid (DNA) testing is essential to solving violent crimes; and

WHEREAS, the Department primarily enlists the services of Serological Research Institute for the timely processing of DNA testing; and

WHEREAS, it is essential to have an accredited laboratory in order to ensure the consistent processing of DNA evidence; and

WHEREAS, the Berkeley Police Department has identified DNA testing services as an operational expense for which the Department is responsible and funds from the State Proposition 172 Fund will be the primary source of funding. If annual usage exceeds the available budget in the State Proposition 172 Fund, the General Fund will be used to augment the support budget for these essential services; and

NOW THEREFORE, BE IT RESOLVED by the Council of the City of Berkeley that, the City Manager is authorized to execute the contract and any amendments with Serological Research Institute to provide DNA testing and analysis services for an additional three years through June 30, 2022 and an additional \$250,000 for an amount not to exceed \$750,000, subject to the City's annual budget appropriation process.





Office of the City Manager

CONSENT CALENDAR  
April 23, 2019

To: Honorable Mayor and Members of the City Council  
 From: Dee Williams-Ridley, City Manager  
 Submitted by: Phillip L. Harrington, Director, Department of Public Works  
 Subject: Contract: Bay Cities Paving & Grading, Inc. for Street Rehabilitation & Surface Seals FY 2019 Project

RECOMMENDATION

Adopt a Resolution approving plans and specifications for the Street Rehabilitation & Surface Seals Project, Specification No. 19-11271-C; accepting the bid of Bay Cities Paving & Grading, Inc. as the lowest responsive and responsible bidder; and authorizing the City Manager to execute a contract and any amendments, extensions or other change orders until completion of the project, in accordance with the approved plans and specifications in an amount not to exceed \$5,688,307.

FISCAL IMPACTS OF RECOMMENDATION

Funding is available from the Street Capital Improvement Program budget. No other funding is required, and no other projects will be delayed due to this expenditure.

|                                |                    |
|--------------------------------|--------------------|
| Low bid by Contractor          | \$5,171,188        |
| 10% Contingency                | \$ 517,119         |
| <b>Total construction cost</b> | <b>\$5,688,307</b> |

FY 2019 Funding:

|                                                                    |                    |
|--------------------------------------------------------------------|--------------------|
| Street & Transportation Capital Improvement Program Funds          |                    |
| State Transportation Tax (127-54-623-673-0000-000-431-665110)..... | \$388,687          |
| Measure B Sales Tax (130-54-623-673-0000-000-431-665110) .....     | \$724,000          |
| Measure BB Sales Tax (134-54-623-673-0000-000-431-665110) .....    | \$1,564,340        |
| Capital Improvement Fund (501-54-623-673-0000-000-431-665110)...   | \$1,048,997        |
| Road Maintenance & Rehabilitation Account (SB1)                    |                    |
| (127-54-623-673-0000-000-431-665110)                               | \$1,962,283        |
| <b>Total construction cost</b>                                     | <b>\$5,688,307</b> |

This contract has been assigned CMS No. AX2WU.

CURRENT SITUATION AND ITS EFFECTS

The Street Rehabilitation & Surface Seals FY 2019 Project (Specification No. 19-11271-C) was released for bids on January 28, 2019, and bids were opened on February 21, 2019 (see Attachment 3, Abstract of Bids). Four non-local bids were received, from a low

of \$5,171,188 to a high of \$8,609,602. Bay Cities Paving & Grading, Inc. of Concord, California was the lowest responsive and responsible bidder, with a bid of \$5,171,188, and their references were found to be satisfactory. This project includes a 10% contingency, which brings the total contract amount up to the requested \$5,688,307. Staff recommends a contract for this project be awarded to Bay Cities Paving & Grading, Inc.

The Street Rehabilitation & Surface Seals FY 2019 Project is a Strategic Plan Priority Project, advancing our goal to provide state-of-the art, well-maintained infrastructure, amenities, and facilities.

### BACKGROUND

Streets throughout Berkeley are scheduled for rehabilitation as part of the City's Five-Year Street Rehabilitation Plan. Berkeley maintains a rolling 5-Year Street Rehabilitation Plan for resurfacing and repaving City streets. The plan is generated with the aid of a sophisticated Pavement Management System developed by the Metropolitan Transportation Commission. The plan was most recently updated for Fiscal Years 2019 through 2023 by Resolution 68,717-N.S. adopted by Council on December 11, 2018. The Street Rehabilitation and Repair Policy created by Resolution 55,384-N.S. and updated by Resolution 64,733-N.S. to include permeable paving, contains the basic criteria for developing the plan and includes the following:

- Street condition,
- Type of repair required,
- Cost effectiveness,
- Amount and type of traffic,
- Designation as an AC Transit bus route or City bikeway
- Coordination with other City programs, e.g., sanitary sewers, storm drains, and utility undergrounding districts, and
- Coordination with utility company work, e.g., PG&E, EBMUD, AT&T, and Comcast.

This contract is for construction of approximately 2.3 miles of City streets, and consists of rehabilitation and surface seal of selected streets as shown in Attachment 2: Location Map & List of Streets.

In addition to street pavement, the project incorporates many other improvements to selected streets as part of a "complete street" approach that repairs or replaces street infrastructure such as curb ramps, curbs, sidewalks, drainage inlets and pipes, gutters, street signage, and striping. Among these incorporated complete street improvements are Bicycle Plan and Pedestrian Master Plan recommendations for an upgraded bicycle lane on 6<sup>th</sup> Street and high visibility crosswalks. These non-pavement related costs represent approximately 30% to 40% of the construction costs.

The project plans and specifications have gone through planning, coordinating with outside utility companies, preliminary cost estimates, field investigations, surveys, and extensive design prior to being released for bid.

The plans and specifications are on file in the Public Works Department. In accordance with the requirements of the California Environmental Quality Act (CEQA), these projects have been determined to be categorically exempt because they consist of maintenance of existing streets and do not expand their use beyond existing conditions.

The Living Wage Ordinance does not apply to this project since Public Works construction contracts are, pursuant to City policy, subject to State prevailing wage laws. Bay Cities Paving & Grading, Inc. has submitted a Certification of Compliance with the Equal Benefits Ordinance. The Community Workforce Agreement applies to this project because the estimated value of the project exceeds \$500,000. As a result, the contractor and all subcontractors will be required to sign an agreement to be bound by the terms of the Agreement.

#### ENVIRONMENTAL SUSTAINABILITY

During analysis and revision of the Five-Year Street Rehabilitation Plan, these project locations were analyzed for possible green infrastructure improvements to treat urban runoff before entering the storm drain system. Due to underlying soil and geographic conditions and existing land use, it was determined that green infrastructure improvements would be more beneficial at alternative paving locations. The project includes rubberized cape seal and rubberized hot mix asphalt treatments which will divert waste tires from local landfills.

#### RATIONALE FOR RECOMMENDATION

This street repair project is part of the City's ongoing annual program to rehabilitate deteriorated streets throughout the City. The work requires contracted services, as the City does not possess the in-house labor or equipment resources necessary to complete the project.

#### ALTERNATIVE ACTIONS CONSIDERED

No alternative actions were considered for this pavement rehabilitation project. The City could choose not to proceed with this project. However, the street pavement would then continue to deteriorate and drainage improvements would not be made, affecting use by the community and others.

#### CONTACT PERSON

Nisha Patel, Manager of Engineering & City Engineer (510) 981-6406  
Joe Enke, Supervising Civil Engineer (510) 981-6411

#### Attachments:

- 1: Resolution
- 2: Location Map & List of Streets for Project
- 3: Abstract of Bids

RESOLUTION NO. ##,###-N.S.

CONTRACT: BAY CITIES PAVING & GRADING, INC. FOR STREET  
REHABILITATION & SURFACE SEALS FY 2019 PROJECT

WHEREAS, the Street Rehabilitation & Surface Seals FY 2019 Project is part of the City's ongoing Street Capital Improvement Program to rehabilitate deteriorated streets located throughout the City; and

WHEREAS, the City has neither the labor nor the equipment necessary to undertake this Street Rehabilitation & Surface Seals FY 2019 Project; and

WHEREAS, an invitation for bids was duly advertised and Bay Cities Paving & Grading, Inc. was the lowest responsive and responsible bidder; and

WHEREAS, funding is available in the current year budget in the Street and Transportation Capital Improvement Program State Transportation Tax (Fund 127), Measure B Sales Tax (Fund 130), Measure BB Sales Tax (Fund 134), and Capital Improvement Fund (Fund 501); and the contract has been entered into the Citywide contract database with CMS No. AX2WU.

NOW THEREFORE, BE IT RESOLVED by the Council of the City of Berkeley that the Plans and Specification No. 19-11271-C for the Street Rehabilitation & Surface Seals FY 2019 Project are approved.

BE IT FURTHER RESOLVED that the Council of the City of Berkeley authorizes the City Manager to execute a contract and any amendments, extensions or change orders, until completion of the project in accordance with the approved plans and specifications with Bay Cities Paving & Grading, Inc. for the Street Rehabilitation & Surface Seals FY 2019 Project, in an amount not to exceed \$5,688,307, which includes a 10% contingency for unforeseen circumstances. A record signature copy of said agreement and any amendments to be on file in the Office of the City Clerk.

Street Rehabilitation & Surface Seals FY 2019

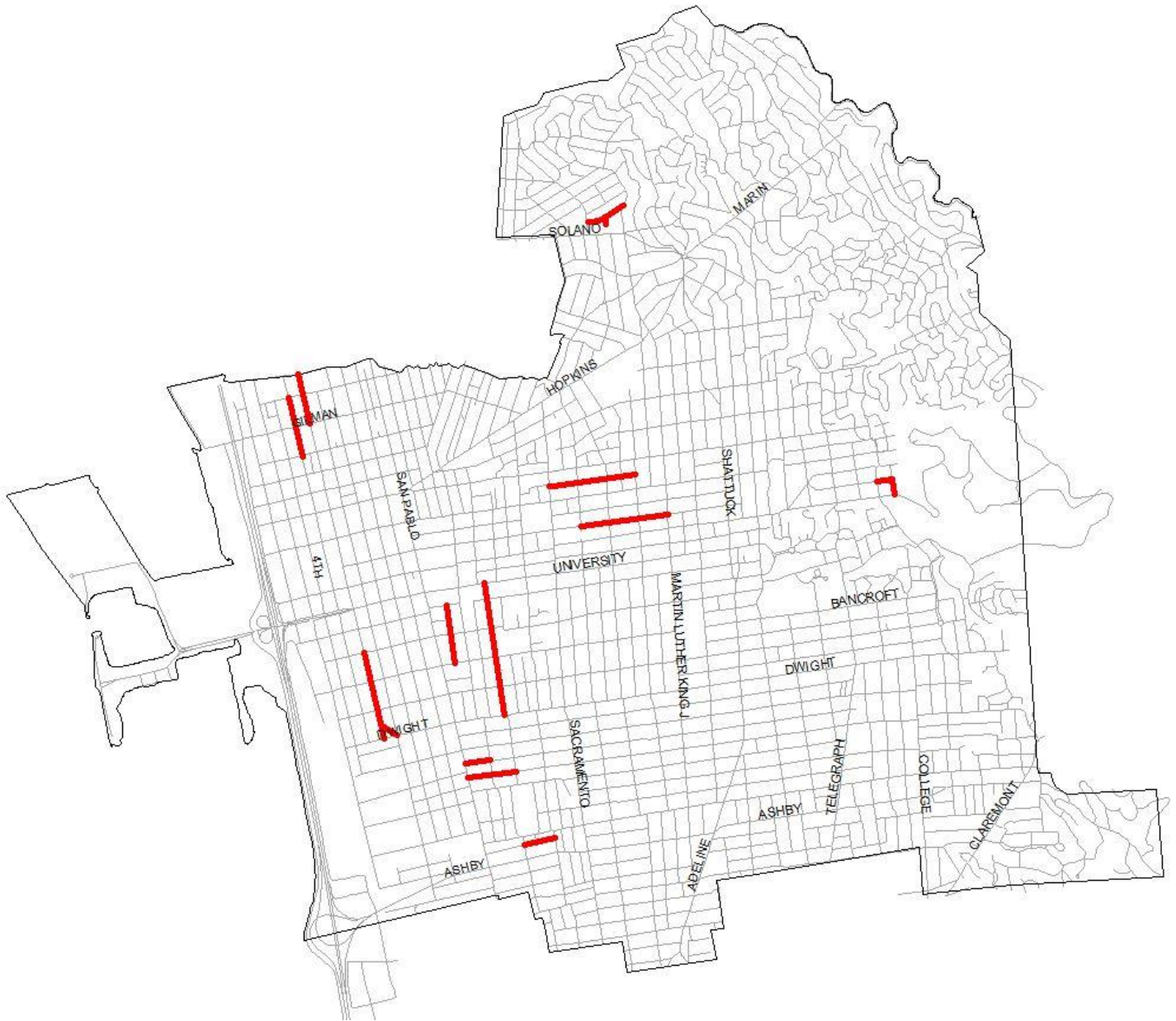

## Street Rehabilitation &amp; Surface Seals FY 2019

| <b>Street</b>   | <b>From</b>   | <b>To</b>      |
|-----------------|---------------|----------------|
| 5th             | Harrison      | Camelia        |
| 6th             | N. City Limit | Gilman         |
| 6th             | Allston       | Dwight         |
| Bonar           | University    | Dwight         |
| Burnett         | Mabel         | Acton          |
| Byron           | Addison       | Bancroft       |
| Carleton        | San Pablo     | Mathews        |
| Catalina        | Colusa        | The Alameda    |
| Delaware        | California    | M. L. King Jr. |
| Derby           | San Pablo     | Mabel          |
| Dwight Crescent | 6th           | 7th            |
| Highland Place  | Ridge         | Hearst         |
| Lincoln         | Sacramento    | Grant          |
| Ridge           | La Loma       | Highland Pl    |
| Station Place   | Catalina      | South End      |



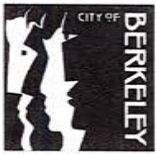

City of Berkeley  
Abstract of Bids Worksheet

Finance Department  
General Service Division

For: Street Rehabilitation + Surface Seals

Specification#: 19-11271-C

Engineer's Estimate: ~~3,000,000.00~~ 5,500,000.00 USD

Bid Date: 02/21/19

|    | Bidders                     | Base Bid     | Nuc Free | Work Force Comp | Opp. States | Living Wage | EBO | Bid Bond | Addendum |
|----|-----------------------------|--------------|----------|-----------------|-------------|-------------|-----|----------|----------|
| 1  | Bay Cities Paving + Grading | 5,177,187.62 | /        | /               | /           | /           | /   | /        | 1        |
| 2  | Gallegher + Built Inc.      | 5,355,675.00 | /        | /               | /           | /           | /   | /        | /        |
| 3  | Interstate Grading + Paving | 5,402,520.60 | /        | /               | /           | /           | /   | /        | /        |
| 4  | Telfer Pavement Tech        | 8,609,603.03 | /        | /               | /           | /           | /   | /        | /        |
| 5  |                             |              |          |                 |             |             |     |          |          |
| 6  |                             |              |          |                 |             |             |     |          |          |
| 7  |                             |              |          |                 |             |             |     |          |          |
| 8  |                             |              |          |                 |             |             |     |          |          |
| 9  |                             |              |          |                 |             |             |     |          |          |
| 10 |                             |              |          |                 |             |             |     |          |          |

Bid Recorder: [Signature] 02/21/19

Bid Opener: [Signature] 2/21/19

Project Manager: [Signature] 2/21/19





Office of the City Manager

CONSENT CALENDAR  
April 23, 2019

To: Honorable Mayor and Members of the City Council  
From: Dee Williams-Ridley, City Manager  
Submitted by: Phillip L. Harrington, Director, Department of Public Works  
Subject: Contract No. 10276A Amendment: Interface Engineering, Inc. for On-Call Electrical Engineering Services

RECOMMENDATION

Adopt a Resolution authorizing the City Manager to execute an amendment to the contract with Interface Engineering, Inc., Contract No. 10276A, for on-call electrical engineering consulting services, increasing the contract amount by \$90,000, for an amount not-to-exceed \$220,000, and extending the contract from June 30, 2019 to June 30, 2020.

FISCAL IMPACTS OF RECOMMENDATION

The proposed amendment increases Interface’s contract amount by \$90,000 from \$130,000 to a not to exceed amount of \$220,000. The following funding source and amount are estimates as funding for these on-call contracts will be identified and expended only for actual electrical engineering consulting services required within the contract period.

|                                             |          |
|---------------------------------------------|----------|
| Measure T1 Infrastructure & Facilities Fund |          |
| 511-54-623-677-0000-000-444-612310.....     | \$70,000 |
| Capital Improvement Fund                    |          |
| 501-54-623-677-0000-000-444-612310.....     | \$20,000 |

This amendment has been entered into the Contract Management System (CMS) as No. A5HBG.

CURRENT SITUATION AND ITS EFFECTS

The Departments of Public Works (Public Works) and Parks, Recreation, and Waterfront (Parks) require electrical engineering consulting services from Interface to assist implementing the City’s T1 Program and the Capital Improvement Program. The current not to exceed on-call contract amount of \$130,000 is projected to be depleted by the end of April in 2019. The contract will require additional funding to provide coverage for on-going electrical projects, such as the Corporation Yard Maintenance Building, the Marina Corporation Yard Maintenance Building, and the Ann Chandler Public Health Center (Berkeley Health Clinic). The additional funding will also provide coverage until new Electrical On-Call consultants are selected. Staff plans to send out a new Request

for Qualifications for electrical engineering consulting services in August and have a new contract in place in the Spring of 2020. The services provided by this contractor support the Strategic Plan goal to provide state-of-the-art, well-maintained infrastructure, amenities, and facilities and the T1 Strategic Priority Project "Berkeley Health Clinic Electrical Improvements".

#### BACKGROUND

On July 2, 2013, the City issued a Request for Qualification (RFQ) for On-Call Electrical Design Services (Specification No. 13-10746-C) for capital improvement projects. On July 18, 2013, the City received eleven submissions, which were reviewed and rated. Interface was found to be the most qualified to provide the services.

On October 15, 2013, by Resolution No. 66335-N.S, Council approved the award of a \$100,000 contract for the period of October 2, 2013 through October 2, 2016.

On May 10, 2016, by Resolution No. 67,469-N.S., Council approved an amendment to increase the contract amount by \$30,000 to a not-to-exceed amount of \$130,000, and extended the term of the contract from October 2, 2016 to June 30, 2018. This amendment was for the additional electrical work required for the Microgrid Project, including switchgears, smart-inverters, or battery setup.

On May 3, 2018, the City Manager approved an extension to term of contract from June 30, 2018 to June 30, 2019. This extension was necessary to continue on-going and new work until the end of June 2019.

#### ENVIRONMENTAL SUSTAINABILITY

There are no anticipated negative environmental effects of this action.

#### RATIONALE FOR RECOMMENDATION

Electrical engineering services are required for this project as the City does not have the in-house expertise to complete this specialized work.

#### ALTERNATIVE ACTIONS CONSIDERED

An alternative would be to delay the amendment until the new consultants are under contract. This would delay current projects.

#### CONTACT PERSON

Andrew Brozyna, Deputy Director, Department of Public Works (510) 981-6396  
Elmar Kapfer, Supervising Civil Engineer, Department of Public Works (510) 981-6435

Attachments:

1: Resolution

RESOLUTION NO. ##,###-N.S.

CONTRACT NO. 10276A AMENDMENT: INTERFACE ENGINEERING, INC. FOR ON-CALL ELECTRICAL ENGINEERING DESIGN SERVICES

WHEREAS, on July 2, 2013, the City issued a Request for Qualification (RFQ) for On-Call Electrical Design Services (Specification No. 13-10746-C) for capital improvement projects. On July 18, 2013, the City received eleven submissions, which were reviewed and rated. Interface was found to be the most qualified to provide the services; and

WHEREAS, on October 15, 2013 by Resolution No. 66335-N.S. City Council authorized Contract No. 10276 with Interface Engineering Inc. in an amount not to exceed \$100,000 for electrical engineering services for facilities capital improvement projects for the period of October 2, 2013 through October 2, 2016; and

WHEREAS, on May 10, 2016 by Resolution No. 67,469-N.S. the City Council authorized Contract No. 10276A to increase not to exceed amount to \$130,000 and extend the term from October 2, 2016 to June 30, 2018; and

WHEREAS, on May 3, 2018, the City Manager approved an extension to term of contract from June 30, 2018 to June 30, 2019; and

WHEREAS, City staff does not have the experience to provide needed electrical engineering services; and

WHEREAS, the current contracted not to exceed amount is projected to be depleted by March 30, 2019 and the City has need of Interface Engineering, Inc.'s continued electrical engineering services through June 30, 2020; and

WHEREAS, funds are available from the Capital Improvement Fund and Measure T1 Infrastructure & Facilities Fund, and the contract has been entered into the City database with Contract Management System (CMS) No. A5HBG.

NOW THEREFORE, BE IT RESOLVED by the Council of the City of Berkeley that the City Manager is authorized to execute an amendment to Contract No. 10276A with Interface Engineering, Inc. increasing the amount by \$90,000 for an amount not to exceed \$220,000 and extending the contract period from June 30, 2019 through June 30, 2020.





Office of the City Manager

CONSENT CALENDAR

April 23, 2019

To: Honorable Mayor and Members of the City Council

From: Dee Williams-Ridley, City Manager

Submitted by: Phillip L. Harrington, Director, Department of Public Works

Subject: Authorize Negotiation in the Open Market for the FY2018 Measure M Low Impact Development (LID) Woolsey Street Project, Specification 18-11183-C

RECOMMENDATION

Adopt a Resolution: (1) accepting staff report that no bids were received when Specification No. 18-11183-C, FY2018 Measure M Low Impact Development Woolsey Street Project was re-advertised; and (2) authorizing the City Manager to negotiate in the open market in accordance with Article XI, Public Works and Supplies, Section 67(a.) of the City Charter.

FISCAL IMPACTS OF RECOMMENDATION

Funding is available from the Measure M Streets & Watershed General Obligation Bond in the Storm Water System Capital Improvement Program budget. There are no fiscal impacts until a contract is negotiated.

CURRENT SITUATION AND ITS EFFECTS

The FY2018 Measure M Low Impact Development (LID) Woolsey Street Project (Specification No. 18-11183-C) was released for bids on May 8, 2018, and bids were opened on June 7, 2018. One bid was received for \$2,864,707. The low bid exceeded the available budget for the project and was approximately \$1.3 million over the Engineer's estimate of \$1.5 million. Council passed Resolution No. 68,566–N.S. on July 24, 2018 authorizing the City Manager to reject the bid and direct staff to re-advertise the project. Staff re-advertised on October 18, 2018 and no bids were received when the bidding period closed on November 15, 2018. Staff has assessed the situation and has discussed the design with, and received inquiries from, contractors expressing interest in this project. If allowed to negotiate with the City, contractors indicate they will explore methods to reduce the challenge of installing the large underground cistern, simplifying construction, and reducing risk of affecting other underground infrastructure due to the large size of the proposed cistern. Staff believes the project can be negotiated in the open market in accordance with the City Charter Article XI, Public Works and Supplies, Section 67(a.). The FY2018 Measure M LID Woolsey Street Project is a Strategic Plan Priority Project and advances the City's goal to create a resilient, safe, connected, and prepared city.

### BACKGROUND

Measure M provides the City with funding for street repaving and installation of LID treatment and watershed improvements consistent with the Watershed Management Plan (WMP) adopted by Council in October 2012. The primary purpose of the LID improvements is treatment of polluted urban runoff and reduction of flooding. This project is for construction of a bio-swale and installation of a large underground cistern on Woolsey Street between Adeline Street and Tremont Street (see Attachment 2, Location Map). The high demand for construction in the Bay Area has contractors operating at full capacity. Staff believes the conditions of high demand and a limited pool of qualified contractors have driven prices up and reduced contractors' interest in bidding on this unique project.

### ENVIRONMENTAL SUSTAINABILITY

Staff believes authorizing the City Manager to negotiate in the open market will allow the City to efficiently use the City's Measure M funds and maximize the amount of LID installations to treat polluted urban runoff and provide flood control within Berkeley's heavily urbanized condition during the current period of high demand for construction.

### RATIONALE FOR RECOMMENDATION

The City put the FY2018 Measure M LID Woolsey Street Project, Specification No. 18-11183-C, out to bid twice and has not received a reasonable bid for the project. There is no indication that bidding the project for a third time will provide the City with an acceptable bid. The City does not possess the in-house labor or equipment resources necessary to construct the project.

### ALTERNATIVE ACTIONS CONSIDERED

Staff has already exercised authority to advertise and bid the project a second time as authorized by Resolution No. 68,566–N.S, Attachment 3. No bids were received when this project was bid a second time. Therefore, staff proposes to move forward with negotiating a contract in the open market. Staff believes advertising and bidding the project for a third time would not be beneficial and that negotiating in the open market is the best alternative. Further, the City has neither the labor nor the equipment necessary to undertake the construction phase of this project in-house.

### CONTACT PERSON

Nisha Patel, Manager of Engineering & City Engineer (510) 981-6406

Joe Enke, Supervising Civil Engineer (510) 981-6411

Danny Akagi, Associate Civil Engineer (510) 981-6394

#### Attachments:

1: Resolution

2: Location Map

3: Resolution No. 68,566–N.S.



RESOLUTION NO. ##,###-N.S.

AUTHORIZE NEGOTIATION IN THE OPEN MARKET FOR THE FY2018 MEASURE M LOW IMPACT DEVELOPMENT (LID) WOOLSEY STREET PROJECT, SPECIFICATION 18-11183-C

WHEREAS, the FY2018 Measure M LID Woolsey Street Project is a Strategic Plan Priority Project and advances the City's goal to create a resilient, safe, connected, and prepared city; and

WHEREAS, the FY2018 Measure M Low Impact Development (LID) Woolsey Street Project is part of the City's ongoing Clean Stormwater Capital Improvement Program to implement recommendations from the Watershed Management Plan; and

WHEREAS, the City has neither the labor nor the equipment necessary to undertake the FY2018 Measure M Low Impact Development (LID) Woolsey Street Project; and

WHEREAS, the FY2018 Measure M Low Impact Development (LID) Woolsey Street Project was previously and duly advertised (Specification No. 18-11183-C) resulting in a single bid received on June 7, 2018; and

WHEREAS, Council passed Resolution No. 68,566-N.S. on July 24, 2018 authorizing the City Manager to reject bids received on June 7, 2018 and direct staff to re-advertise the FY2018 Measure M Low Impact Development (LID) Woolsey Street Project; and

WHEREAS, the FY2018 Measure M Low Impact Development (LID) Woolsey Street Project was re-advertised and, upon closing of the bidding period on November 15, 2018, no bids were received; and

WHEREAS, staff is recommending Council authorize the City Manager to negotiate the project in the open market in accordance with the City Charter Article XI, Public Works and Supplies, Section 67(a.).

NOW THEREFORE, BE IT RESOLVED by the Council of the City of Berkeley that the Council accepts staff's report that no bids were received for the FY2018 Measure M Low Impact (LID) Woolsey Street Project on November 15, 2018; and

BE IT FURTHER RESOLVED that the City Manager is authorized to negotiate in the open market with contractors for the FY2018 Measure M Low Impact Development (LID) Woolsey Street Project.

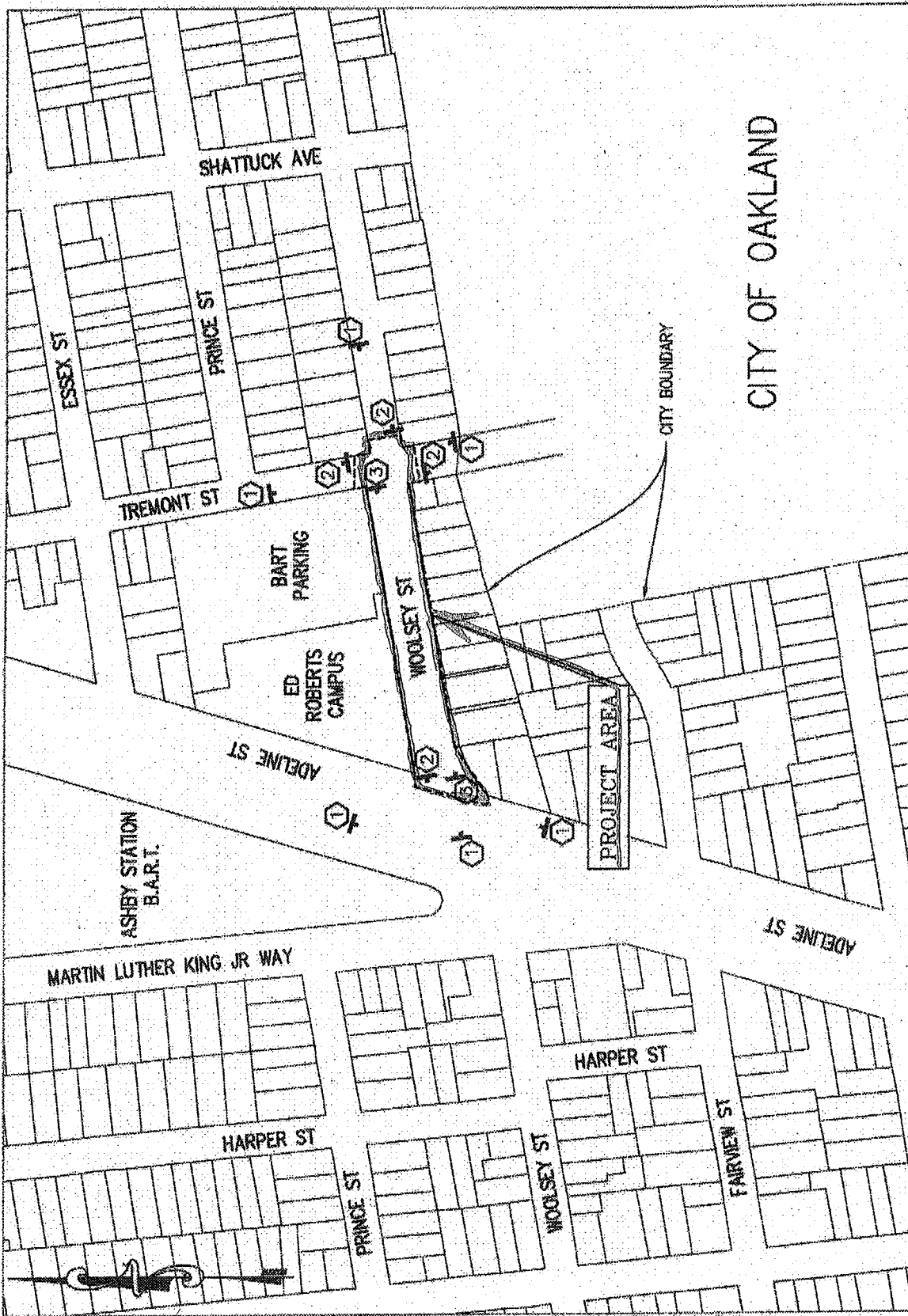

ATTACHMENT  
2

FY2018 MEASURE  
M

WOOLSEY STR.  
PROJECT

LOCATION MAP

RESOLUTION NO. 68,566-N.S.

REJECT BIDS AND DIRECT STAFF TO RE-ADVERTISE THE FY2018 MEASURE M LOW IMPACT DEVELOPMENT (LID) WOOLSEY STREET PROJECT

WHEREAS, the FY2018 Measure M Low Impact Development (LID) Woolsey Street Project (Project) is part of the City's ongoing Clean Stormwater Capital Improvement Program to implement recommendations from the Watershed Management Plan; and

WHEREAS, the City has neither the labor nor the equipment necessary to undertake this FY2018 Measure M Low Impact Development (LID) Woolsey Street Project; and

WHEREAS, an invitation for bids was duly advertised (Specification No. 18-11183-C), on which the sole bid received was from Pacific Infrastructure Construction, LLC, and as the bid exceeded the City's estimate and available budget for the Project; and

WHEREAS, staff have evaluated the bid received and determined it to be in the City's best interest to re-advertise the project.

NOW THEREFORE, BE IT RESOLVED by the Council of the City of Berkeley that the bid from Pacific Infrastructure Construction, LLC is rejected and the City Manager is authorized to re-bid the FY2018 Measure M Low Impact Development (LID) Woolsey Street Project, Specification No. 18-11183-C.

The foregoing Resolution was adopted by the Berkeley City Council on July 24, 2018 by the following vote:

Ayes: Bartlett, Davila, Droste, Hahn, Harrison, Maior, Wengraf, Worthington and Arreguin.

Noes: None.

Absent: None.

  
\_\_\_\_\_  
Jesse Arreguin, Mayor

Attest:   
\_\_\_\_\_  
Mark Numainville, City Clerk





Housing Advisory Commission

CONSENT CALENDAR

April 23, 2019

To: Honorable Mayor and Members of the City Council  
 From: Housing Advisory Commission  
 Submitted by: Xavier Johnson, Chairperson, Housing Advisory Commission  
 Subject: Resources for Community Development's 2001 Ashby Avenue  
 Predevelopment Loan Application

RECOMMENDATION

Authorize funding for the Resources for Community Development (RCD) predevelopment loan application for \$368,000 for its proposed development at 2001 Ashby Avenue.

FISCAL IMPACTS OF RECOMMENDATION

While there is not presently funding available in the City of Berkeley's Housing Trust Fund, the city is capable of allocating other resources to ensure the future success and viability of this predevelopment project for \$368,000.

CURRENT SITUATION AND ITS EFFECTS

At its February 7, 2019 meeting, the Housing Advisory Commission voted unanimously to support this \$368,000 pre-development loan to Resources for Community Development for its proposed development at 2001 Ashby. The votes for the meeting are located below.

Action: M/S/C (Tregub/Sargent) to recommend to the City Council to support Resources for Community Development's predevelopment loan application for \$368,000 for its proposed development at 2001 Ashby Avenue.

Vote: Ayes: Johnson, Lord, Sargent, Sharenko, Simon-Weisberg, Tregub, and Wright.  
 Noes: None. Abstain: None. Absent: Owens (excused) and Wolfe (recused).

BACKGROUND

This project is rated highly in terms of feasibility and addressing long term and systemic challenges in the South Berkeley and Adeline corridor area. By also serving as a location for the site of Healthy Black Homes, the project eventually will function as a convenient and effective location to address some of the communities hardest hit by displacement and gentrification within the City of Berkeley.

Resources for Community Development was selected by the Cooperative Center Federal Credit Union (CCFCU) after an RFP process. With 55-year affordability requirements, this development can serve the low-income community for years to come. Given the harshness of the housing crisis, this predevelopment loan application will move the needle forward in protecting everyone's right to safe and affordable housing.

#### ENVIRONMENTAL SUSTAINABILITY

Environmental impacts for a predevelopment loan will be none or minimal as the funding merely goes to research the feasibility and possible environmental impacts of a future development.

#### RATIONALE FOR RECOMMENDATION

This proposal, while it will need to be supported by additional money not currently present within the Housing Trust Fund, would help advance a reliable project that has been vetted by the Cooperative Center Federal Credit Union (CCFCU) for development. We are all aware of the Housing crisis hitting Berkeley and the East Bay and this project represents an important opportunity to preserve community, and to invest in affordable housing in the City of Berkeley.

#### ALTERNATIVE ACTIONS CONSIDERED

The Housing Advisory Commission considered other options such as not funding the predevelopment application, but found that the best step forward was to find a way to provide predevelopment funding for this particular project.

#### CITY MANAGER

The City Manager concurs with the content and recommendations of the Commission's Report. Since no funds are available from the Housing Trust Fund at this time, the Council could refer this item to a Policy Subcommittee and/or to the Measure O Oversight Commission for consideration.

It is important to note that at the time of the Housing Advisory Commission recommendation, RCD estimated a City subsidy of approximately \$6 million. Subsequent to that recommendation, RCD revised its City subsidy estimate to nearly \$18 million. The increase is largely due to the unavailability of certain funding sources, including Alameda County A1 funds. It is typical for funding estimates to change during the predevelopment phase, as the project evolves and as the developer explores different funding options. RCD also revised the number, type, and affordability levels of the proposed rental units. The unit count increased from 85 to 88 units, and would include a roughly equal mix of studio, one-, two-, and three-bedroom apartments. Six units would be available to households earning up to 80% of the area median income (AMI), with the remainder serving households earning up to 30%, 50%, and 60% AMI.

#### CONTACT PERSON

Amy Davidson, Commission Secretary, HHCS, (510) 981-5406

Attachments:

- 1: Staff Memo to the Housing Advisory Commission - Resources for Community Development 2001 Ashby Predevelopment Loan Application



Health Housing and  
Community Services Department  
**Housing & Community Services Division**

## MEMORANDUM

**To:** Housing Advisory Commission (HAC)

**From:** Amy Davidson, Senior Community Development Project Coordinator

**Date:** January 28, 2019

**Subject:** Resources for Community Development 2001 Ashby Predevelopment Loan Application

### Recommendation

At its December 10, 2018 meeting, the Commission's Housing Trust Fund subcommittee voted to recommend Resources for Community Development's (RCD) predevelopment loan application for \$368,000 for its proposed development at 2001 Ashby, the current site of the Cooperative Center Federal Credit Union (CCFCU). (M/S/C: Tregub/Johnson)

The Housing Trust Fund guidelines allow project sponsors to apply for predevelopment funding at any time, with all recommendations for greater than \$50,000 going to the City Council for consideration. At this time, all the local funding in the Housing Trust Fund has been reserved for the Berkeley Way development so no funds are available. In November, voters passed Measure O, which will provide bond funding for affordable housing. Council has not yet identified priorities for this funding and will be working through its Policy Committee and with the to-be-appointed bond oversight bond to evaluate priorities. If the HAC recommended funding for this project, the Council's options include referring the project to one of those bodies for consideration.

### Housing Trust Fund Guidelines

The City's Housing Trust Fund guidelines:

- Allow predevelopment loan applications to be submitted at any time.
- State that predevelopment loans are "generally" the lesser of \$50,000 or \$5,000 per unit, but in practice the City has often exceeded this guideline.
- Limit predevelopment loans to the lesser of \$100,000 or 10% of funds in any year. Exceeding that limit requires Council action, which has been done before. Council reserved \$29.5M in HTF funding in 2018.

*A Vibrant and Healthy Berkeley for All*



### **Project Description**

CCFCU issued an RFP to select an organization to develop their site at 2001 Ashby and selected Berkeley-based RCD. CCFCU and RCD have entered into a Memorandum of Understanding outlining their plan for RCD to acquire the site and build 85 affordable apartments with ground floor commercial space, including space for Healthy Black Families. Because CCFCU wishes to sell by fall 2019, RCD is working to gain land use entitlements and complete its due diligence before then.

RCD is proposing 85 units, with a mix of studio, one-, two- and three-bedroom apartments affordable to households at or below 30% to 60% of area median income. Some of them would be set-aside for a to-be-determined special needs population, perhaps people who are homeless. RCD is committing \$28,000 of their working capital in addition to their staffing during this period. The predevelopment costs RCD is requesting assistance with include architecture and engineering expenses (45%), related testing, permits and fees, and a purchase deposit to CCFCU. These are all typical predevelopment period costs and are at a reasonable level for a project of this size.

### **Summary Analysis**

The HTF Subcommittee reviewed the staff analysis of developer capacity, feasibility, and community objectives:

- Staff concluded that the proposed team is well qualified to undertake the proposed project. RCD is an experienced, Berkeley-based developer well known to City staff and the community, having developed and owning 56 buildings in the Bay Area. There are no outstanding findings on any RCD projects the City funded in the past.
- In addition to a feasible predevelopment proposal, the proposed project has many key elements of a feasible development: an experienced development team, site control, a flat, infill 0.6 acre site in an excellent location (adjacent to the Ashby BART station) that is zoned for multifamily housing, and proximity to amenities like Berkeley Bowl, in a better funding climate than has existed for years, with new state and local sources. The proposed size of 85 units will probably help make the project both more cost effective and competitive. RCD projects requesting about \$6M from the City for development; this number is likely to change during the predevelopment period as RCD gathers information and other funding.
- This site is in the Adeline Corridor Planning area, and during that planning process, participants have identified a need for more affordable housing in the neighborhood. Participants have also raised alarm with the decreasing African American population in South Berkeley, and this project could help address that issue by providing space for Healthy Black Families.





Housing Advisory Commission

CONSENT CALENDAR  
April 23, 2019

To: Honorable Mayor and Members of the City Council  
 From: Housing Advisory Commission  
 Submitted by: Xavier Johnson, Chairperson, Housing Advisory Commission  
 Subject: Senate Constitutional Amendment 1 and Assembly Bill 10

### RECOMMENDATION

Endorse Senate Constitutional Amendment (SCA) 1 and Assembly Bill (AB) 10.

### FISCAL IMPACTS OF RECOMMENDATION

There are no direct fiscal impacts to supporting (SCA) 1 and (AB) 10.

### CURRENT SITUATION AND ITS EFFECTS

The pieces of legislation described below have each been recently introduced for the 2019-2020 legislative session. The Berkeley Housing Advisory Commission considered both (SCA) 1 and (AB) 10 and recommended that the City Council endorse both measures at the February 7, 2019 Housing Advisory Commission meeting. The voting results are included below.

Action: M/S/C (Tregub/Sargent) to recommend to City Council to endorse Senate Constitutional Amendment (SCA) 1.

Vote: Ayes: Johnson, Lord, Sargent, Sharenko, Simon-Weisberg, Tregub, Wolfe and Wright. Noes: None. Abstain: None. Absent: Owens (excused).

Action: M/S/C (Tregub/Sargent) to recommend to City Council to endorse Assembly Bill (AB) 10.

Vote: Ayes: Johnson, Sargent, Sharenko, Simon-Weisberg, Tregub, Wolfe and Wright. Noes: Lord. Abstain: None. Absent: Owens (excused).

### BACKGROUND

(SCA) 1 – introduced by Senators Allen and Wiener and co-authored by Senator Lara – propose that an amendment be placed on a future California State ballot that repeals Article 34 of the California State Constitution. This article presently “prohibits the development, construction, or acquisition of a low-rent housing project ... in any manner by any state public body until a majority of the qualified electors of the city, town, or

county in which [such a project] is proposed approve [it] by voting in favor at an election...”<sup>1</sup>

(AB 10) – introduced by Assembly Members Chiu, Bonta, Maienschein, Reyes, and Wicks and with multiple coauthors) – “for calendar years beginning in 2020, would increase the aggregate [low-income] housing [tax] credit dollar amount that may be allocated among low-income housing projects by an additional [\$500 Million] ... and would allocate to farmworker housing projects [\$25 Million] of that amount.”<sup>2</sup>

#### ENVIRONMENTAL SUSTAINABILITY

Investment in affordable housing opportunities, when coupled with viable transit options, has been found to contribute to reductions in vehicle miles traveled and greenhouse gas emission reductions.

#### RATIONALE FOR RECOMMENDATION

The Berkeley City Council supports various efforts to invest in affordable housing, including at the state level.

#### ALTERNATIVE ACTIONS CONSIDERED

The Berkeley City Council can recommend for endorsement on a portion of the proposed pieces of legislation, or propose additional legislation to the endorsement request. While other housing bills of interest have been introduced for the 2019-2020 legislative session, their language is likely to change significantly in the coming months. Hence it is recommended that the City of Berkeley watches these bills, but takes no action at this time on these other bills.

#### CITY MANAGER

The City Manager concurs with the content and recommendations of the Commission’s Report.

#### CONTACT PERSON

Amy Davidson, Commission Secretary, HHCS, (510) 981-5406

---

<sup>1</sup>

[http://leginfo.legislature.ca.gov/faces/billTextClient.xhtml?bill\\_id=201920200SCA1&search\\_keywords=articl+34](http://leginfo.legislature.ca.gov/faces/billTextClient.xhtml?bill_id=201920200SCA1&search_keywords=articl+34)

<sup>2</sup> [http://leginfo.legislature.ca.gov/faces/billNavClient.xhtml?bill\\_id=201920200AB10](http://leginfo.legislature.ca.gov/faces/billNavClient.xhtml?bill_id=201920200AB10)

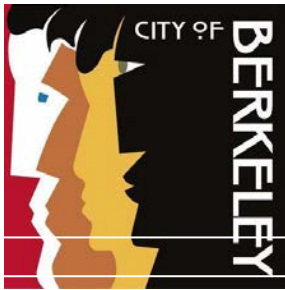

City of Berkeley, District 3  
2180 Milvia Street, 5<sup>th</sup> Floor  
Berkeley, CA 94704  
PHONE 510-981-7130  
EMAIL: [bbartlett@cityofberkeley.info](mailto:bbartlett@cityofberkeley.info)

CONSENT CALENDAR  
April 23, 2019

To: Honorable Mayor and Members of the City Council  
From: Councilmember Ben Bartlett  
Subject: Authorize Sending a Letter of Support for AB-953 “Cannabis: state and local taxes: payment by digital asset” to Assemblymember Phil Ting

RECOMMENDATION:

That the City Council authorize sending a letter of support for AB-953 to Assemblymember Ting. AB-953 will allow state and local tax authorities to collect cannabis-generated taxes via stable digital currencies. This will help to address legal cannabis businesses’ underbanking problem.

BACKGROUND:

In 2016, California voters passed Proposition 64 - the Adult Usage Marijuana Act. Today, California represents about a third of the North American cannabis market with the state taking in more than \$345 million in taxes last year alone. Proposition 64 was designed to create new revenue for the state and address public safety concerns by driving out the illegal market. However, these efforts are being compromised by cannabis businesses’ inability to engage in traditional banking services.

As a result, 70% of legal cannabis-related businesses across the US do not have a bank account, meaning this entire industry is run almost entirely in cash, creating profound implications for the industry’s sustainability, safety, and ability to pay taxes. In response to this, the Cannabis Banking Working Group (CBWG) was formed to address these concerns and concluded that while the current situation cannot stand, no policy outside of federal action could resolve this issue.

A possible solution is the use of stablecoins. A stablecoin is an electronic virtual currency tied to the US Dollar, thus inoculating the virtual currency from volatility. Therefore, stablecoins provide the same stability as cash, but are easier, safer, and less costly to administer.

To restate, AB-953 authorizes state and local tax agencies to use stablecoin to collect cannabis-related taxes. AB-953 presents an interim solution that will help realize legal cannabis’ promise of improved public safety and new revenue sources.

For more information:

[https://leginfo.legislature.ca.gov/faces/billNavClient.xhtml?bill\\_id=201920200AB953](https://leginfo.legislature.ca.gov/faces/billNavClient.xhtml?bill_id=201920200AB953)

FINANCIAL IMPLICATIONS:

Minimal

ENVIRONMENTAL SUSTAINABILITY:

Consistent with Berkeley's Environmental Sustainability Goals and no negative impact.

CONTACT PERSON:

|                            |              |
|----------------------------|--------------|
| Councilmember Ben Bartlett | 510-981-7130 |
| Brian Gan                  | 510-981-7131 |

Attachment: (if necessary)

1. Draft Letter of Support

## Attachment 1:

April 1, 2019

The Honorable Assemblymember Phil Ting  
 California State Assembly  
 State Capitol  
 P.O. Box 942849  
 Sacramento, CA 94249

RE: Assembly Bill 953 (Ting) – Cannabis state and local taxes payment by digital asset - SUPPORT

Dear Assemblymember Ting,

The Honorable Mayor and Members of the Berkeley City Council are pleased to support AB 953, which will help address legal cannabis businesses' underbanking problem by allowing state and local tax authorities to collect cannabis-generated taxes via stablecoin, providing a safe and cost-effective solution.

In 2016, California voters passed Proposition 64 – the Adult Usage Marijuana Act – with 57 percent of the vote. Today, California represents about a third of the North American cannabis market with the state taking in more than \$345 million in taxes last year alone (California Department of Tax and Fee Administration). Proposition 64 was designed to bring in new revenue for the state as well as address public safety concerns by driving out the illegal market. The post-Proposition 64 reality has been compromised by cannabis businesses' inability to engage in traditional banking services.

As a result, 70% of legal cannabis-related businesses across the US do not have a bank account, meaning this billion dollar industry is run almost entirely in cash. For its part, California state government is bringing in hundreds of millions of dollars in cash delivered by armored vehicle. This underbanking has profound implications for the legal cannabis industry's sustainability, safety, and ability to pay taxes. This is why the California State Treasurer convened the Cannabis Banking Working Group (CBWG) to address these concerns. In its 2018 report, CBWG concluded that while the status quo cannot stand, without federal action to legalize cannabis, no policy could solve this problem.

[Title of Report]

CALENDAR

Stable virtual currency, also known as stablecoin, may provide a workable solution to cannabis' cash problem. Stablecoin is tied to the US Dollar which inoculates the cryptocurrency from volatility experienced by other types of virtual currency. As such, stablecoin provides the same stability as cash but is far easier, safer, and less costly to administer. Examples of stablecoins on the market include TrueUSD, UPUSD, and USDC – a stablecoin backed by Goldman Sachs.

Authorizing state and local tax agencies to collect and remit cannabis related taxes as an interim solution will help deliver on cannabis legalization's promise for improved public safety as well as new and greater revenue sources. For these reasons and more, the Honorable Mayor and Members of the Berkeley City Council are proud to support AB 953.

Respectfully,  
the Honorable Mayor and Members of the Berkeley City Council

Jesse Arreguin  
Mayor, City of Berkeley

Members of the Berkeley City Council





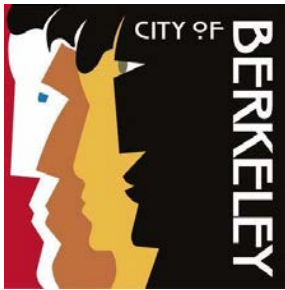

City of Berkeley, District 3  
2180 Milvia Street, 5<sup>th</sup> Floor  
Berkeley, CA 94704  
PHONE 510-981-7130  
EMAIL: [bbartlett@cityofberkeley.info](mailto:bbartlett@cityofberkeley.info)

CONSENT CALENDAR  
April 23rd, 2019

To: Honorable Mayor and Members of the City Council  
From: Councilmembers Ben Bartlett and Cheryl Davila  
Subject: The Center for Food, Faith, and Justice and Green the Church:  
Relinquishment of Council Office Budget Fund to General Fund and Grant  
of Such Funds

RECOMMENDATION:

Adopt a resolution approving the expenditure of an amount not to exceed \$500 per council member, including \$500 from Councilmember Bartlett, to the “Black, Green, and Traumatized: Environmental Trauma and Mental Health” event hosted by The Center for Food, Faith, and Justice and Green the Church on April 27th from 10am-3pm at McGee Avenue Baptist Church, 1640 Stuart Street, Berkeley, CA 94703. The funds will be relinquished to the city’s general fund for this purpose from the discretionary council office budget of Councilmember Ben Bartlett and any other council members who would like to contribute.

BACKGROUND:

The Center for Food, Faith, and Justice (CFFJ) is a nonprofit group that aims to address various interconnected social and environmental issues, such as poverty, and the relationship between huge health disparities and a rise in violence, in the South Berkeley community. CFFJ operates a wide range of initiatives, such as cooking classes for all ages and youth fellowship programs that act as outreach to neighborhoods to address nutrition, sustainability and housing issues.

Green the Church (GTC) is an initiative designed to tap into the power and purpose of the African American church community, and to explore and expand the role of churches as centers for environmental and economic resilience. The initiative works to empower all church members to develop practical solutions to economic and environmental issues in the Black community.

Donating to the “Black, Green, and Traumatized: Environmental Trauma and Mental Health” event hosted by The Center for Food, Faith, and Justice and Green the Church will provide the necessary resources for these organizations to educate and empower their communities on health, sustainability, and ecology resources.

FISCAL IMPACTS OF RECOMMENDATION

No General Fund impact; \$500 is available from fund. The cost is as follows: Donation to the “Black, Green, and Traumatized: Environmental Trauma and Mental Health” event hosted by the Center for Food, Faith, and Justice and Green the Church (\$500).

CONTACT PERSON:

Councilmember Ben Bartlett                      510-981-7130  
Brian Gan                                                      510-981-7131

RESOLUTION NO. ##,###-N.S.

AUTHORIZE THE EXPENDITURE OF SURPLUS FUNDS FROM THE OFFICE EXPENSE ACCOUNTS OF THE MAYOR AND COUNCIL MEMBERS FOR A GRANT TO THE CENTER FOR FOOD, FAITH, AND JUSTICE AND GREEN THE CHURCH TO PROVIDE PUBLIC SERVICES FOR A MUNICIPAL PUBLIC PURPOSE

**WHEREAS**, Councilmember Ben Bartlett has surplus funds in their office expenditure account; and

**WHEREAS**, California non-profit tax-exempt corporations – The Center for Food, Faith, and Justice and Green the Church - will receive funds in the amount of \$500; and

**WHEREAS**, The Center for Food, Faith, and Justice and Green the Church are nonprofit groups that provide access to health and sustainability education for underprivileged populations; and

**WHEREAS**, the provision of such services would fulfill the following municipal public purpose of providing educational programs, health equity, and promote cultural diversity among Berkeley residents; and

**NOW, THEREFORE, BE IT RESOLVED** by the Council of the City of Berkeley that funds relinquished by the Mayor and council members from their council office budget of up to \$500 per office shall be granted to the “Black, Green, and Traumatized: Environmental Trauma and Mental Health” event hosted by The Center for Food, Faith, and Justice and Green the Church.

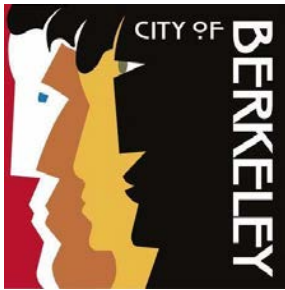

City of Berkeley, District 3  
2180 Milvia Street, 5<sup>th</sup> Floor  
Berkeley, CA 94704  
PHONE 510-981-7130  
EMAIL: [bbartlett@cityofberkeley.info](mailto:bbartlett@cityofberkeley.info)

CONSENT CALENDAR

April 23rd, 2019

To: Honorable Mayor and Members of the City Council  
From: Councilmembers Ben Bartlett and Cheryl Davila  
Subject: Black Repertory Group Theater: Relinquishment of Council Office Budget Fund to General Fund and Grant of Such Funds

RECOMMENDATION:

Adopt a resolution approving the expenditure of an amount not to exceed \$3,000 per council member, including \$3,000 from Councilmember Bartlett, to the Black Repertory Group, with funds relinquished to the city's general fund for this purpose from the discretionary council office budget of Councilmember Ben Bartlett and any other council members who would like to contribute.

BACKGROUND:

The Black Repertory Group is a long standing theatrical griot group that provides access to the dramatic arts for members from underserved populations. As a nonprofit organization, the Black Repertory Group Theater has provided access for and support to minority populations to learn and rediscover their cultural heritage through the productions of dramas, music, and dances. The theater has also been vital in helping young people raise their self-esteem, educating them on health and wellness, and preparing them for future careers. Donating to the Black Repertory Group Theater can enhance Berkeley's cultural diversity and allow constituents to explore and learn artistic and practical skills.

FISCAL IMPACTS OF RECOMMENDATION

No General Fund impact; \$3,000 is available from fund. The cost is as follows: Donation to the Black Repertory Theater (\$3,000).

CONTACT PERSON:

Councilmember Ben Bartlett 510-981-7130  
Brian Gan 510-981-7131

RESOLUTION NO. ##,###-N.S.

AUTHORIZE THE EXPENDITURE OF SURPLUS FUNDS FROM THE OFFICE  
EXPENSE ACCOUNTS OF THE MAYOR AND COUNCIL MEMBERS FOR A GRANT  
TO BLACK REPERTORY GROUP TO PROVIDE PUBLIC SERVICES FOR A  
MUNICIPAL PUBLIC PURPOSE

**WHEREAS**, Councilmember Ben Bartlett has surplus funds in their office expenditure account; and

**WHEREAS**, a California non-profit tax-exempt corporation – the Black Repertory Group will receive funds in the amount of \$3,000; and

**WHEREAS**, the Black Repertory Group is a long standing theatrical griot group that provides access to the performance arts for underprivileged populations; and

**WHEREAS**, the Black Repertory Group provides education on African American history and their theater work is a cultural treasure to our community; and

**WHEREAS**, the provision of such services would fulfill the following municipal public purpose of providing educational programs, and promote cultural diversity among Berkeley residents; and

**NOW, THEREFORE, BE IT RESOLVED** by the Council of the City of Berkeley that funds relinquished by the Mayor and council members from their council office budget of up to \$3,000 per office shall be granted to the Black Repertory Group.

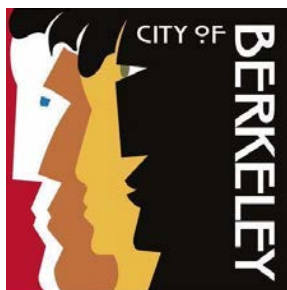

## Councilmember Ben Bartlett

City of Berkeley, District 3  
 2180 Milvia Street, 5<sup>th</sup> Floor  
 Berkeley, CA 94704  
 PHONE 510-981-7130  
 EMAIL: [bbartlett@cityofberkeley.info](mailto:bbartlett@cityofberkeley.info)

### CONSENT CALENDAR

April 23rd, 2019

To: Honorable Mayor and Members of the City Council  
 From: Councilmember Ben Bartlett and Mayor Jesse Arreguin  
 Subject: U1 Funds for Predevelopment Costs of Proposed Development at 2001 Ashby Avenue

#### RECOMMENDATION:

Adopt a Resolution allocating \$368,000 of General Funds from Measure U1 tax receipts to Resources for Community Development (RCD) for predevelopment costs at 2001 Ashby Avenue.

#### CURRENT SITUATION:

The Housing Trust Fund guidelines allow project sponsors to apply for predevelopment funding at any time, with all recommendations for greater than \$50,000 going to the City Council for consideration.

RCD is proposing approximately 88 units of Affordable Housing at 2001 Ashby Avenue, the current site of the Cooperative Center Federal Credit Union (CCFCU). The development will include a mix of studio, one-, two- and three-bedroom apartments affordable to households at 20% to 80% of area median income. A number of units would be set-aside for a to-be-determined special needs population perhaps people who are homeless. RCD has been using its own predevelopment working capital and staffing since starting the project in 2017. The predevelopment costs RCD requests assistance which include architecture and engineering expenses, related testing, permits and fees, and a purchase deposit to CCFCU, the current site owner. These represent typical predevelopment costs and are reasonable for a project of this size.

In November 2018 RCD submitted an application to the City requesting \$368,000 in predevelopment funds. On December 10, 2018 the Housing Advisory Commission's Housing Trust Fund Subcommittee voted to recommend RCD's predevelopment loan application for \$368,000 for its proposed development at 2001 Ashby. On January 28, 2019 the Housing Advisory Commission (HAC) recommended that the City Council support RCD's predevelopment loan application. At issue is the availability of affordable housing trust fund dollars due to prior commitments to the Berkeley Way project.

#### BACKGROUND:

CCFCU issued an RFP in April 2017 to select an organization to develop their site at 2001 Ashby and selected Berkeley-based RCD. CCFCU and RCD have entered into a purchase and sale agreement for RCD to acquire the site by November 2019 and build 88 affordable apartments with ground floor commercial space, including space for the

non-profit organization Healthy Black Families. Because CCFCU wishes to sell by fall 2019, RCD is working to gain land use entitlements and complete its due diligence before then.

Measure U1 was passed by voters in November 2016 with the goal of providing \$3 to \$4 Million annually to the Berkeley General Fund. The measure designated the HAC to advise the Council on expenditures to create affordable housing to prevent homelessness. The proposed affordable housing development at 2001 Ashby meets the objectives of Measure U1.

#### RATIONALE FOR RECOMMENDATION

The City's fund commitment is needed at this time to enable the project to conduct predevelopment activities.

The proposed development for the site includes affordable housing which will benefit the public.

#### FISCAL IMPACTS OF RECOMMENDATION

RCD has requested \$368,000 from the City for predevelopment activities.

#### ENVIRONMENTAL SUSTAINABILITY

There are no negative environmental sustainability impacts directly associated with this action, which is for planning, environmental testing, and design activities.

#### CONTACT PERSON

Councilmember Ben Bartlett

510-981-7130

RESOLUTION NO. ##,###-N.S.

RESERVING \$368,000 IN U1 FUNDS FOR PREDEVELOPMENT COSTS TO RESOURCES FOR COMMUNITY DEVELOPMENT'S PROPOSED DEVELOPMENT OF 2001 ASHBY AVENUE

WHEREAS, the City Council established a Housing Trust Fund Program (HTF) to assist in the development and expansion of housing affordable to low and moderate income persons who either work or reside within the City of Berkeley, and authorized the City Manager to implement the Program; and

WHEREAS, there is a great need for affordable and special needs housing in the City of Berkeley, as stated in the General Plan Housing Element and the City of Berkeley's Consolidated Plan; and

WHEREAS, the Housing Advisory Commission reviewed the proposal and the staff's analysis on January 28, 2019 and agreed with the staff and Housing Trust Fund subcommittee recommendation to fund predevelopment costs at \$368,000.

WHEREAS, Measure U1 designated the Housing Advisory Commission to advise the Council on expenditures to create affordable housing to prevent homelessness.

NOW THEREFORE, BE IT RESOLVED by the Council of the City of Berkeley that it approves the following for RCD's development of 2001 Ashby Avenue:

- A reservation of \$368,000 in U1 Funds for predevelopment costs of the proposed project.

BE IT FURTHER RESOLVED that the City Manager, or her designee, is hereby authorized to execute all original or amended documents or agreements to effectuate this action; a signed copy of said documents, agreements, and any amendments will be kept on file in the Office of the City Clerk.







Kate Harrison  
Councilmember District 4

CONSENT CALENDAR  
April 23<sup>rd</sup>, 2019

To: Honorable Mayor and Members of the City Council  
From: Councilmembers Kate Harrison and Cheryl Davila  
Subject: Budget Referral: Good Government Ombudsman

RECOMMENDATION

Refer to the 2019/2020 budget process to establish a Good Government Ombudsman to facilitate enforcement of Berkeley's good government laws through the City Clerk and City Attorney's Office.

BACKGROUND

Representative democracy requires transparency and accountability. In the post-Citizens United<sup>1</sup> landscape, big money<sup>2</sup> and lobbyists<sup>3</sup> can have an outsized effect on government undertakings. The people of Berkeley have enacted a series of reforms to support these values, beginning with the Berkeley Election Reform Act of 1974, a ballot measure that passed overwhelmingly and limited the amount of campaign contributions, among other reforms.

To promote the highest possible standard of ethical accountability, integrity, and independence among City employees and elected officials, Berkeley has a suite of "good governance" laws -- the Berkeley Election Reform Act (1974), the Open Government Ordinance (2010), the Revolving Door Ordinance (2016), the Fair Elections Act of 2016 (Public Financing), and the Lobbyist Ordinance (2018).

A City Manager memo dated November 20, 2018 (attached) indicated that City administration is currently staffed to adequately enforce the Berkeley Election Reform Act, the Open Government Ordinance, and the Revolving Door Ordinance, but the mandates created by Public Financing Act have drawn employees away from other duties and implementation of the Lobbyist Ordinance is not fully feasible with current staffing levels.

The Fair Elections Act of 2016 established a public financing program to reduce the influence of private campaign contributions and ensure that personal wealth is not a

<sup>1</sup> <https://www.law.cornell.edu/supct/html/08-205.ZS.html>

<sup>2</sup> <https://citizenstakeaction.org/the-problem/>

<sup>3</sup> <https://www.theatlantic.com/business/archive/2015/04/how-corporate-lobbyists-conquered-american-democracy/390822/>

barrier to becoming an elected official. In two election cycles, the Fair Elections Act has already proven effective at achieving these goals, but the filing demands on the City Clerk's Office are burdensome and require more staff. Thus far, the Fair Elections Act has been enforced with existing staff because it is applicable only during election years, but the City Clerk's Office has had to shift employees from other functions to fulfill those duties.

The Berkeley City Council passed the Lobbyist Ordinance on October 2, 2018 with the intention of the City registering all lobbyists, providing ethics training, and maintaining quarterly reports. Thus far enforcement has been infeasible because of lack of staff.

An additional 1.0 FTE, designated as a Deputy City Attorney II, would allow full enforcement of the suite of good government laws including the Lobbyist Ordinance. Berkeley should invest in the principles of accountability by allocating funding for the 1.0 FTE the City Attorney office requires to enforce the laws Berkeley has already passed.

#### FISCAL IMPACTS OF RECOMMENDATION

According to the City Manager memo, approximately \$240,000 annually.

#### ENVIRONMENTAL SUSTAINABILITY

Consistent with Berkeley's climate and sustainability goals.

#### CONTACT PERSON

Kate Harrison, Berkeley City Councilmember, (510) 981-7140

#### ATTACHMENTS

1: Fiscal and Administrative Impacts of the Lobbyist Ordinance



Office of the City Manager

November 20, 2018

To: Honorable Mayor and Members of the City Council

From: Dee Williams-Ridley, City Manager

Subject: Fiscal and Administrative Impacts of the Lobbyist Ordinance

---

On October 16, 2018 the City Council adopted the second reading of Ordinance No. 7,629-N.S. the Lobbyist Registration and Regulation Ordinance. This new set of regulations will be effective on January 1, 2020.

At the first reading of the ordinance on October 2, 2018, the City Council requested that the City Manager provide an analysis of the costs and staff demands for implementation of the Lobbyist Ordinance. This specific analysis is provided below. When analyzing the impact of the Lobbyist Ordinance, it is important to consider the impact of administering the full package of Berkeley's "good government" laws – the Berkeley Election Reform Act (1974), the Open Government Ordinance (2010), the Revolving Door Ordinance (2016), the Fair Elections Act of 2016 (Public Financing), and the Lobbyist Ordinance (2018).

Current staffing levels have been adequate to administer the existing mandates in the Berkeley Election Reform Act (BERA), the Open Government Ordinance (OGO), and the Revolving Door Ordinance. The addition of Public Financing in 2016 and the Lobbyist Ordinance in 2018 create two new significant mandates that are not accounted for in current staffing levels. In addition, neither mandate was adopted with a new revenue source and are funded from existing General Fund revenues.

As you will see below, the implementation of the Lobbyist Ordinance is a significant undertaking. To successfully implement and administer the Lobbyist Ordinance while continuing to administer and enforce existing "good government" laws staff estimates that 1.0 new FTE in the Deputy City Attorney II classification is required. The addition of a full FTE in the City Attorney's Office will allow for administrative and enforcement tasks to be properly re-distributed between the City Clerk Department and City Attorney's Office so that each department can have the bandwidth to absorb the new mandates. The fully loaded (salary plus benefits) cost of the new FTE is approximately

**\$239,804.** In addition to the staff cost, a new software module for lobbyist filings is estimated to cost approximately **\$20,000 per year.**

### **Lobbyist Registration Ordinance**

In evaluating the estimates for the costs to implement the Lobbyist Ordinance, staff based the estimates on implementation of a similar projects, the Public Financing Ordinance. However, it is likely that the administrative and enforcement demands for the Lobbyist Ordinance will exceed that of Public Financing. The Public Financing Ordinance is more intermittent in its demands on staff with most of the work falling around specific deadlines in an election year. The Lobbyist Ordinance will have more regular ongoing demands as lobbyists are registering and paying the fee throughout the year, completing their training on a rolling basis, and filing quarterly statements in every year. There will also likely be a more constant flow of complaints compared to BERA complaints that generally only arise during election season.

In addition, the estimates are difficult as staff does not know how many lobbyists will register and how many enforcement actions will there be year over year.

#### Components of Implementation (Dec. 2018 – Dec. 2019)

- Enhancement of NetFile System for Lobbyist Filing and Tracking
- Design of Required Forms
- Education for City Staff
- Education for Open Government Commission (OGC) Members
- Developing OGC Procedures for Administration, Investigation, and Enforcement
- Development of Required Trainings for Registered Lobbyists
- Development of Supplemental Regulations
- Development of Filing Procedures for Lobbyists
- Development of Staff Procedures
- Public Outreach and Education

#### Implementation Staff Demands (Dec. 2018 – Dec. 2019)

Estimated Staff Time (Current Staff) for Implementation:

15% Deputy Attorney  
 10% Senior Legal Secretary  
 50% Assistant Management Analyst  
 25% Assistant City Clerk

### Software Costs

A purely paper-based filing system for lobbyist registration and reporting would not result in any additional software costs. However, the information contained in the filings would not be searchable or downloadable by the public and would be less transparent and user-friendly to review. Paper-based systems are more labor-intensive and will add to the staff time demands and costs because the filings must be mailed or hand-delivered to the city, then staff must scan the filings, manually redact addresses, e-mails, and phone numbers, then manually upload them into the tracking system.

For an electronic filing system, the cost can vary significantly based on the complexity and features of the system. NetFile, our current e-filing vendor for campaign, public financing, and Form 700 filings, has experience with lobbyist registration systems in other cities. They estimate that a basic e-filing system for lobbyist forms would cost at least **\$20,000 per year** and could increase depending on the built-in features. Of course, the benefit of electronic filing systems are that the information is available to public more quickly, the information is searchable and downloadable, it is easier for the filers to file, and requires less staff time to process.

### Ongoing Lobbyist Ordinance Requirements

- Filer Education, Training, Questions and Advice
- Initial and Annual Registration Tracking
- Registration Form Review
- Fee Collection and Accounting
- Quarterly Filing Noticing and Tracking
- Quarterly Non-Filing Enforcement
- Mandated 5% Audit of Filings
- Training Noticing and Tracking
- Training Certification Enforcement
- OGC Complaint Summary Reports
- OGC Enforcement Investigations
- OGC Enforcement Action Stipulation Negotiations

### Ongoing Lobbyist Ordinance Staff Demands

15% Deputy City Attorney  
 10% Senior Legal Secretary  
 15% Investigator  
 20% Assistant Management Analyst  
 10% Assistant City Clerk

### Oakland's Experience

Oakland's Public Ethics Commission ("PEC") is tasked with enforcing the Oakland Lobbyist Registration Ordinance. By way of background, the PEC has six (6) staff members including the Executive Director, Deputy Director/Prosecutor, two Ethics Analysts, an Investigator and an Administrative Assistant II. Oakland advised us that they have an administrative person who spends about a quarter of her time as the filing officer for lobbyist registrations and reports. Their investigators spend about 15% of their time investigating allegations relating to the Ordinance and the Prosecutor spends about the same amount on prosecution, although they believe more staffing is needed. In addition, they receive legal support from the City Attorney's Office.

### **Administration of All Berkeley Good Government Laws**

As mentioned above, Berkeley currently has a complete suite of "Good Government Laws" including the Berkeley Election Reform Act (1974), the Open Government Ordinance (2010), the Revolving Door Ordinance (2016), the Fair Elections Act of 2016 (Public Financing), and the Lobbyist Ordinance (2018). All of these laws are jointly administered and enforced by the City Attorney's Office and the City Clerk Department. The Lobbyist Ordinance is the third good government law added to the municipal code in the past two years without any new dedicated funding or increased staffing. All additional administration and enforcement has been completed with existing FTEs and all funds have come from existing General Fund sources.

In addition to this set of laws, the City Council has approved moving forward with the development of a **policy committee** structure for the City Council. This new committee structure will have significant benefits for the development and consideration of legislation, but will also significantly add to the staff demands in the City Clerk Department and the City Attorney's Office.

The estimated ongoing staff demands for current laws (BERA, Revolving Door, OGO, Public Financing):

- 35% of Deputy Attorney
- 15% of Senior Legal Secretary
- 65% Assistant Management Analyst
- 50% Assistant City Clerk

The estimated ongoing staff demands for the Lobbyist Ordinance:

15% Deputy City Attorney  
10% Senior Legal Secretary  
15% Investigator  
20% AMA  
10% ACC

The estimated ongoing staff demands for current laws + the Lobbyist Ordinance:

50% of Deputy Attorney  
30% of Senior Legal Secretary  
15% Investigator  
85% AMA  
60% Assistant City Clerk

The total, cumulative staff demands of this group of laws is estimated to be 2.40 FTEs.

Approximately 1.0 FTE are adequate staffing for BERA, OGO, and Revolving Door administration. The remaining 1.4 FTE for the Lobbyist Ordinance and Public Financing are a deficit to current staffing levels. The addition of the 1.0 FTE in the City Attorney's Office mentioned at the top of this memo should provide adequate staffing for the implementation phase of the Lobbyist Ordinance. Depending on the number of lobbyists that register with the City and the number of enforcement actions initiated, additional staffing may be required.







Kate Harrison  
Councilmember District 4

CONSENT CALENDAR  
April 23<sup>rd</sup>, 2019

To: Honorable Mayor and Members of the City Council

From: Councilmembers Kate Harrison, Cheryl Davila, Sophie Hahn,  
and Rigel Robinson

Subject: Support for Zero Emission Bills

RECOMMENDATION

1. Adopt a resolution of support for two bills that will move California towards eliminating greenhouse gas emissions from the transportation sector: AB 40, which calls for all cars sold in California to be zero-emission by 2040, and AB 1418, which calls for all public school buses in California to be zero-emission by 2030.
2. Send letter of support to Senator Skinner and Assemblymember Wicks.

BACKGROUND

Both AB 40 and AB 1481 are California state bills that aim to eliminate fossil fuels in our transportation sector. AB 40 (Ting and Kalra) would require the state to develop a comprehensive strategy to ensure that the sales of all new motor vehicles in California are zero-emission vehicles by 2040. AB 1418 (Chiu) would require, starting in 2020, each public utility to create comprehensive reports to the California Energy Commission on their efforts to convert all vehicles and infrastructure to be zero-emission. Included in the bill is an ambitious plan to specifically convert school districts and school buses to be zero-emission.

In America, the transportation sector represents roughly 28% of all greenhouse gas emissions. In California, the percentage is even higher at 40%. Zero emission vehicles are increasingly common and an easy way to decrease carbon footprints on an individual and collective scale. AB 40 will make individual purchase of electric cars far easier across the state, and AB 1418 will compel all government agencies in California to decarbonize their infrastructure and transportation and make public investments in green technology.

FISCAL IMPACTS OF RECOMMENDATION

None.

ENVIRONMENTAL SUSTAINABILITY

Every year, Californians emit millions of tons of greenhouse gases as a result of cars and other vehicles that combust petroleum-based products such as gasoline. Transitioning to all electric vehicles will reduce greenhouse gas emissions.

CONTACT PERSON

Kate Harrison, Berkeley City Councilmember, (510) 981-7140

Attachments:

- 1: Resolution
- 2: Letter of Support for AB 40 (Ting)
- 3: Letter of Support for AB 1418 (Chiu)

## RESOLUTION NO. ##-###-N.S.

## RESOLUTION SUPPORTING THE ZERO-EMISSION VEHICLE COMPREHENSIVE STRATEGY (AB 40) AND THE CLEAN BUS BILL (AB 1418)

WHEREAS, the acceleration in global average temperature is leading to the climate changing at incredibly rapid pace; and

WHEREAS, human actions such as burning fossil fuels contribute to the greenhouse gases within the atmosphere, thus increasing the scope of climate change and negatively impacting human and environmental health through pollution; and

WHEREAS, a UN climate report found that net carbon emissions must be reduced to zero by 2050. All greenhouse gas emissions must be reduced by 2030 in order to keep the overall global temperature below a 2 degree Celsius increase tipping point; and

WHEREAS, devastating effects like rising sea levels, increased natural disasters, increased extreme weather events, and overall decreased habitability of the world will occur without rapid changes. This will lead to widespread human health effects like heatstroke, hypothermia, death from natural disaster, mass displacement, and mass loss of life and property will occur<sup>1</sup>; and

WHEREAS, the United States ranks second in the world in total carbon emissions and third in per capita emissions<sup>2</sup>; and

WHEREAS, the United States accounts for over 17% of global carbon emissions<sup>3</sup> and California accounts for over 6.6% of the United States' carbon emissions<sup>4</sup>; and

---

<sup>1</sup> Freeman, David. "We're Falling Short on Efforts to Stop Global Warming. Here's How We Can Get on Track." *NBCNews.com*, NBCUniversal News Group, 9 Oct. 2018, [www.nbcnews.com/mach/science/new-climate-report-shows-efforts-end-global-warming-are-falling-ncna918121](http://www.nbcnews.com/mach/science/new-climate-report-shows-efforts-end-global-warming-are-falling-ncna918121).

<sup>2</sup> "Each Country's Share of CO2 Emissions." *Union of Concerned Scientists*, UCS, 11 Oct. 2018, [www.ucsusa.org/global-warming/science-and-impacts/science/each-countrys-share-of-co2.html](http://www.ucsusa.org/global-warming/science-and-impacts/science/each-countrys-share-of-co2.html).

<sup>3</sup> "Each Country's Share of CO2 Emissions." *Union of Concerned Scientists*, UCS, 11 Oct. 2018, [www.ucsusa.org/global-warming/science-and-impacts/science/each-countrys-share-of-co2.html](http://www.ucsusa.org/global-warming/science-and-impacts/science/each-countrys-share-of-co2.html).

<sup>4</sup> "U.S. Energy Information Administration - EIA - Independent Statistics and Analysis." *State-Level Energy-Related Carbon Dioxide Emissions, 2005-2016*, US Energy Information Administration, 27 Feb. 2019, [www.eia.gov/environment/emissions/state/analysis/](http://www.eia.gov/environment/emissions/state/analysis/).

WHEREAS, 40% of carbon emissions in California come from the transportation sector<sup>5</sup> so to address climate change the number of fossil fuels burned by cars in California must be cut down

WHEREAS, a climate emergency has been declared in Berkeley<sup>6</sup>; and

WHEREAS, two bills recently introduced address the problem of climate change. AB 40 calls for all new cars sold in California to be run off clean energy by the year 2040 and AB 1418 calls for public school buses in California to be replaced with electric school buses by the year 2030;

NOW, THEREFORE, BE IT RESOLVED that the City Council of the City of Berkeley hereby supports Assembly Bill 40 and Assembly Bill 1418.

---

<sup>5</sup> "State CO2 Emissions from Fossil Fuel Combustion, 1990-2016." *Energy Resources for State and Local Governments*, US Environmental Protection Agency, 2016, [www.epa.gov/sites/production/files/2017-09/documents/co2ffc\\_2015.pdf](http://www.epa.gov/sites/production/files/2017-09/documents/co2ffc_2015.pdf).

<sup>6</sup> "Resolution No. 68,486 - N. S.: Endorsing the Declaration of a Climate Emergency." *Berkeley City Council Resolution*, 12 June 2018, [www.cityofberkeley.info/uploadedFiles/Council\\_2/Level\\_3\\_-\\_General/Climate%20Emergency%20Declaration%20-%20Adopted%2012%20June%202018%20-%20BCC.pdf](http://www.cityofberkeley.info/uploadedFiles/Council_2/Level_3_-_General/Climate%20Emergency%20Declaration%20-%20Adopted%2012%20June%202018%20-%20BCC.pdf).

April 23<sup>rd</sup>, 2019

The Honorable Phil Ting  
California State Assembly  
P.O. Box 942849  
Sacramento, CA 94249

**Re: Support from Berkeley City Council for AB 40 (Ting) – Zero Emission Vehicles**

Dear Assemblymember Ting,

Berkeley City Council writes in support of AB 40, a comprehensive strategy to ensure that all sales of motor vehicles have transitioned to zero-emission vehicles by 2040.

In California, 40% of all carbon emissions are derived from our transportation sector. The United Nations Intergovernmental Panel on Climate Change recommends that we aggressively reduce all emissions by 2030, or we risk reaching the 2 degree Celsius tipping point that may cause increased natural disasters and inhabitable climate event.

AB 40 will make the sales of electric vehicles across California far easier and will significantly reduce greenhouse gas emissions from our state.

Thank you for your leadership on climate issues.

Respectfully,  
Berkeley City Council

CC: Assemblymember Buffy Wicks  
Senator Nancy Skinner

April 23<sup>rd</sup>, 2019

The Honorable David Chiu  
California State Assembly  
P.O. Box 942849  
Sacramento, CA 94249

**Re: Support from Berkeley City Council for AB 1418 (Chiu) – Transportation electrification: Electric Schoolbuses**

Dear Assemblymember Chiu,

Berkeley City Council writes in support of AB 1418, which would require each public utility and school district to create comprehensive reports to the California Energy Commission on their efforts to convert all vehicles and infrastructure to be zero-emission.

In California, 40% of all carbon emissions are derived from our transportation sector. The United Nations Intergovernmental Panel on Climate Change recommends that we aggressively reduce all emissions by 2030, or we risk reaching the 2 degree Celsius tipping point that may cause increased natural disasters and inhabitable climate event.

AB 1418 is an ambitious investment in renewable infrastructure and zero-emission vehicles from our state, and will significantly reduce greenhouse gas emissions from our state.

Thank you for your leadership on climate issues.

Respectfully,  
Berkeley City Council

CC: Assemblymember Buffy Wicks  
Senator Nancy Skinner



Kate Harrison  
Councilmember District 4

CONSENT CALENDAR  
April 23, 2019

To: Honorable Mayor and Members of the City Council

From: Councilmembers Harrison, Davila and Bartlett

Subject: Adopt an Ordinance Adding Chapter 13.104 to the Berkeley Municipal Code Establishing a Prohibition on Contracting with Vendors Acting as U.S. Immigration and Customs Enforcement (ICE) Data Brokers, or Those Providing Extreme Vetting Services to ICE

RECOMMENDATION:

That the City Council adopt the attached Sanctuary Contracting Ordinance as amended. This ordinance prohibits the award of city contracts to vendors acting as U.S. Immigration and Customs Enforcement data brokers, or those providing extreme vetting services.

POLICY COMMITTEE RECOMMENDATION:

On March 11, 2019, the Agenda and Rules Committee adopted the following action: M/S/C (Harrison/Arreguin) to send the item to the full Council with a Positive Recommendation. Vote: All Ayes.

BACKGROUND:

The City Council has previously referred a draft ordinance to the Peace and Justice Commission, and the Commission has reviewed, amended, and recommended the adoption of this ordinance. Since that time, Councilmember Harrison met with the City Manager, City Attorney and the Department of Information Technology to further refine the ordinance so that it can be effectively implemented. By adopting this ordinance, the City will protect the privacy, safety, dignity, and quality of life of the members of the Berkeley community, especially targeted immigrants and religious minorities.

FINANCIAL IMPLICATIONS:

City Manager staff time will be necessary in order to review/certify compliance and update prospective contract terms. In addition, City Manager staff time may be necessary in order to submit waiver requests to Council, notify potential violators, conduct investigations and provide legal support in the case of legal proceedings.

ENVIRONMENTAL SUSTAINABILITY:

Consistent with Berkeley's Environmental Sustainability Goals and no negative impact.

CONTACT PERSON:

Councilmember Harrison 510-981-7142

ATTACHMENT:

1. Proposed BMC Chapter 13.104: Sanctuary City Contracting Ordinance



ORDINANCE NO. -N.S.

ADDING CHAPTER 13.104 TO THE BERKELEY MUNICIPAL CODE TO ADOPT A  
SANCTUARY CONTRACTING ORDINANCE

BE IT ORDAINED by the Council of the City of Berkeley as follows:

Section 1. That a new Chapter 13.104 is hereby added to the Berkeley Municipal Code to read as follows:

**Chapter 13.104**

**SANCTUARY CITY CONTRACTING**

**Sections:**

- 13.104.010 Title.**
- 13.104.020 Definitions.**
- 13.104.030 Prohibition on Use of City Resources.**
- 13.104.040 Investigation and Reporting.**
- 13.104.050 Enforcement.**
- 13.104.060 Severability.**
- 13.104.070 Construction.**
- 13.104.080 Chapter Supersedes Existing Law and Regulations.**
- 13.104.090 Effective Date.**

**13.104.010 Title.**

This ordinance shall be known as the Sanctuary City Contracting Ordinance.

**13.104.020 Definitions.**

- A. "City" means the City of Berkeley, California.
- B. "Data Broker" (also commonly called information broker, information reseller, data aggregator, and information solution provider) means either of the following:
  - 1. The collection of information, including personal information about consumers, from a wide variety of sources for the purposes of reselling such information to their customers, which include both private-sector businesses and government agencies;
  - 2. The aggregation of data that was collected for another purpose from that for which it is ultimately used.
- C. "Extreme Vetting" means data-mining, threat modeling, predictive risk analysis, or other similar services.

Extreme Vetting Does not include the following:

  - 1. The City's computer-network health and performance tools;
  - 2. Cybersecurity capabilities, technologies and systems used by the City of Berkeley Department of Information Technology to predict, monitor for, prevent, and protect technology infrastructure and systems owned and operated by the City of Berkeley from potential cybersecurity events and

cyber-forensic based investigations and prosecutions of illegal computer based activity.

D. "ICE" means the United States Immigration and Customs Enforcement, and any subdivision thereof.

E. "Person or Entity" means any private natural person, corporation, institution, subsidiary, affiliate, or division under operating control of such person; the parent entities that have operating control over such person, and the subsidiaries, affiliates and divisions under operating control of such parent entity. Government entities and employees are expressly excluded from this definition.

### **13.104.030 Prohibition on Use of City Resources.**

A. No officer, employee, department, board, commission, City Council, City Manager, or other entity of the City shall enter into a new, amended, or extended contract or agreement with any Person or Entity that provides ICE with any "Data Broker" or "Extreme Vetting" services as defined herein, unless a waiver is granted based on a specific determination that no reasonable alternative exists, taking into consideration the following:

1. The intent and purpose of this ordinance;
2. The availability of alternative services, goods and equipment; and
3. Quantifiable additional costs resulting from use of available alternatives.

The following processes shall be followed in considering a waiver: The City Manager or designee shall file a waiver request. The Council shall make the final decision on granting the waiver.

B. All public works, construction bids, requests for information, requests for proposals or any other solicitation issued by the City shall include notice of the prohibition listed above.

C. For the purpose of determining which Person or Entity provides ICE with Data Broker or Extreme Vetting services, the City Manager shall rely on:

1. Information available on federal contracting websites, or in the absence of those, another common source of federal data;
2. A declaration under the penalty of perjury executed by the Person or Entity, affirming that they do not provide Data Broker or Extreme Vetting services to ICE.

D. Any Person or Entity identified as a supplier of Data Broker or Extreme Vetting services to ICE and potentially affected by this Section shall be notified by the City Manager of the determination. Any such Person or Entity shall be entitled to a review of the determination by appeal to the City Manager. Request for such review shall be made within thirty (30) business days of notification, or seven (7) business days of the date of a City solicitation or notice of a pending contract or purchase, of interest to the Person or Entity seeking review. Any Person or Entity vendor so identified may appeal the City Manager's determination to the City Council, within fifteen (15) business days of the determination.

### **13.104.040 Investigation and Reporting.**

A. The City Manager, or their designee, shall review compliance with Section 13.104.030. The City Manager may initiate and shall receive complains regarding violations of Section 13.104.030. All officers, employees, departments, boards,

commissions, and other entities of the City shall cooperate with the City Manager in any investigation of a violation of Section 13.104.030.

B. By November 1 of each year, the City Manager shall schedule and submit to the City Council a written, public report regarding compliance with Section 13.104.030 over the previous year. At minimum, this report must (1) detail with specificity the steps taken to ensure compliance with Section 13.104.030, (2) disclose any issues with compliance, including any violations or potential violations of this Ordinance, and (3) detail actions taken to cure any deficiencies with compliance.

**13.104.050 Enforcement.**

A. Right to Cure. This Chapter does not provide a private right of action upon any person or entity to seek injunctive relief against the City or any employee unless that person or entity has first provided written notice to the City Manager by serving the City Clerk, regarding the specific alleged violations of this Chapter. If the alleged violation is substantiated and subsequently cured, a notice shall be posted in a conspicuous manner on the City's website that describes, to the extent permissible by law, the corrective measures taken to address the violation.

B. Cause of Action. If a specific alleged violation is not remedied within 90 days of that written notice, a person or entity may institute proceedings for injunctive relief, declaratory relief, or writ of mandate in any court competent jurisdiction to enforce this Ordinance.

C. Civil Penalties. If the City is found liable in a cause of action brought by an individual under subsection B. above for a violation that is the result of arbitrary or capricious action by the City or an employee or agent thereof in their official capacity, the City shall be liable for a civil penalty no greater than \$5,000 per violation, as determined by the court. In determining the amount of civil penalty, the court shall consider prior violations of this ordinance by the City department that committed the violation.

D. Attorney's Fees and Costs. A court shall award a plaintiff who prevails on a cause of action under subsection B. reasonable attorney's fees and costs in an amount not to exceed \$15,000.

E. Limitations on Actions. Any person bringing an action pursuant to this ordinance must first file a claim with the City pursuant to Government Code 905 or any successor statute within four years of the alleged violation.

F. Any contracting Person or Entity knowingly or willingly supplying false information in violation of Section 13.104.030C.2., shall be guilty of a misdemeanor and up to a \$1,000 fine.

**13.104.060 Severability.**

The provisions in this Ordinance are severable. If any part of provision of this Ordinance, or the application of this Ordinance to any person or circumstance, is held invalid, the remainder of this Ordinance, including the application of such part or provisions to other persons or circumstances, shall not be affected by such holding and shall continue to have force and effect.

**13.104.070 Construction.**

The provisions of this Ordinance are to be construed broadly to effectuate the purposes of this Ordinance.

**13.104.080 Chapter Supersedes Existing Law and Regulations.**

The provisions of this chapter shall supersede any conflicting law or regulations.

**13.104.090 Effective Date.**

This Ordinance shall take effect on July 1, 2019.

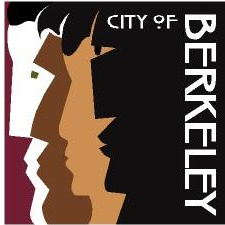

Kate Harrison  
Councilmember District 4

## **REVISED AGENDA MATERIAL for Supplemental Packet 1**

**Meeting Date:** February 26, 2019

**Item Number:** 15

**Item Description:** **Adopt the Sanctuary Contracting Ordinance proposed by the Peace and Justice Commission**

**Submitted by:** **Councilmember Harrison**

Added a right to cure provision in the enforcement section. Amended the Cause of Action subsection to remove the damages provision and limit civil penalties to arbitrary and capricious violations. Limited reasonable attorney's fees and costs to \$15,000.

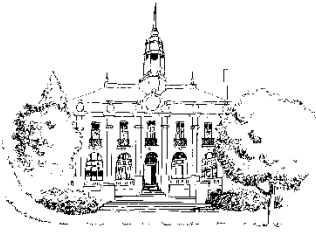

## Kriss Worthington

Councilmember, City of Berkeley, District 7  
2180 Milvia Street, 5<sup>th</sup> Floor, Berkeley, CA 94704  
PHONE 510-981-7170, FAX 510-981-7177,  
EMAIL [kworthington@cityofberkeley.info](mailto:kworthington@cityofberkeley.info)

### ACTION CALENDAR

January-February 26<sup>9</sup>, 2019

*(Continued from November 13, 2018)*

To: Honorable Mayor and Members of the City Council  
From: Councilmember Kate Harrison, Councilmember Kriss Worthington, Councilmember Cheryl Davila, and Councilmember Ben Bartlett

Subject: Adopt the Sanctuary Contracting Ordinance proposed by the Peace and Justice Commission

#### RECOMMENDATION:

That the City Council adopt the attached Sanctuary Contracting Ordinance proposed by the Peace and Justice Commission. This ordinance prohibits the award of city contracts to vendors acting as ICE data brokers, or those providing extreme vetting services.

#### BACKGROUND:

The City Council has previously referred a draft ordinance to the Peace and Justice Commission, and the Commission has reviewed, amended, and recommended the adoption of this ordinance, by a vote of 5-0 with two absent members. This updated and refined version of the Sanctuary Contracting Ordinance by the Peace and Justice Commission would prohibit the award of city contracts to ICE vendors acting as "Data Brokers" or those who provide "Extreme Vetting" services. By adopting this ordinance, the City of Berkeley will protect the privacy, safety, dignity, and quality of life of the members of the Berkeley community, especially targeted immigrants and religious minorities. It is the duty of the city to uphold and promote values of inclusion and shared prosperity.

Here is a link to the Peace and Justice Commission Recommendation with track changes:  
<https://drive.google.com/file/d/1V9nY1BeWSbFOlqb7YF5opB4rlkBKvBqd/view?usp=sharing>

#### FINANCIAL IMPLICATIONS:

Minimal.

#### ENVIRONMENTAL SUSTAINABILITY:

Consistent with Berkeley's Environmental Sustainability Goals and no negative impact.

#### CONTACT PERSON:

Councilmember Kriss Worthington 510-981-7170

ORDINANCE NO. -N.S.

BE IT ORDAINED by the Council of the City of Berkeley as follows:

**Section 1. Title**

This ordinance shall be known as the Sanctuary City Contracting Ordinance.

**Section 2. Definitions**

- 1) "City" means the City of Berkeley, California.
- 2) "Data Broker" (also commonly called information broker, information reseller, data aggregator, and information solution provider) means either of the following:
  - a) The collection of information, including personal information about consumers, from a wide variety of sources for the purposes of reselling such information to their customers, which include both private-sector businesses and government agencies;
  - b) The aggregation of data that was collected for another purpose from that for which it is ultimately used.
- 3) "Extreme Vetting" means data-mining, threat modeling, predictive risk analysis, or other similar services.
- 4) "ICE" means the United States Immigration and Customs Enforcement, and any subdivision thereof.
- 5) "Person or Entity" means any private natural person, corporation, institution, subsidiary, affiliate, or division under operating control of such person; the parent entities that have operating control over such person, and the subsidiaries, affiliates and divisions under operating control of such parent entity. Government entities and employees are expressly excluded from this definition.

**Section 3. Prohibition on Use of City Resources**

- 1) No officer, employee, department, board, commission, City Council, City Manager, or other entity of the City shall enter into a new, amended, or extended contract or agreement with any Person or Entity that provides ICE with any "Data Broker" or "Extreme Vetting" services, as defined herein, unless a waiver is granted based on a specific determination that no reasonable alternative exists, taking into consideration the following:
  - a) The intent and purpose of this ordinance;
  - b) The availability of alternative services, goods and equipment; and
  - c) Quantifiable additional costs resulting from use of available alternatives.The following process shall be followed in considering a waiver: the City Manager or designee shall file a waiver request with the Peace and Justice Commission. The Commission shall weigh the above considerations and make a recommendation to the City Council. The Council shall make the final decision on granting the waiver.
- 2) All public works, construction bids, requests for information, requests for proposals, or any other solicitation issued by the City shall include notice of the prohibition listed above.
- 3) For the purpose of determining which Person or Entity provides ICE with Data Broker or Extreme Vetting services, the City Manager shall rely on:
  - a) Information published by reliable sources
  - b) Information released by public agencies
  - c) A declaration under the penalty of perjury executed by the Person or Entity, affirming that they do not provide Data Broker or Extreme Vetting services to ICE
  - d) Information submitted to the City Manager by any member of the public, and

thereafter duly verified

- 4) Any Person or Entity identified as a supplier of Data Broker or Extreme Vetting services to ICE and potentially affected by this section shall be notified by the City Manager of the determination. Any such Person or Entity shall be entitled to a review of the determination by appeal to the City Manager. Request for such review shall be made within thirty (30) days of notification, or seven (7) days of the date of a City solicitation or notice of a pending contract or purchase, of interest to the Person or Entity seeking review. Any Person or Entity vendor so identified may appeal the City Manager's determination to the City Council, within fifteen (15) days of the determination.

#### **Section 4. Investigation And Reporting**

- (a) The City Manager, or his or her designee, shall review compliance with Section 3. The City Manager may initiate and shall receive complaints regarding violations of Section 3. After investigating such complaints, the City Manager shall issue findings regarding any alleged violation. If the City Manager finds that a violation occurred, the City Manager shall, within 30 days of such finding, send a report of such finding to the City Council, the Mayor, and the head of any department involved in the violation or in which the violation occurred. All officers, employees, departments, boards, commissions, and other entities of the City shall cooperate with the City Manager in any investigation of a violation of Sections 3.
- (b) By April 1 of each year, each City department shall certify its compliance with this ordinance by written notice to the City Manager.
- (c) By May 1 of each year, the City Manager shall schedule and submit to the City Council a written, public report regarding compliance with Section 3 over the previous calendar year. At minimum, this report must (1) detail with specificity the steps taken to ensure compliance with Sections 3, (2) disclose any issues with compliance, including any violations or potential violations of this Ordinance, and (3) detail actions taken to cure any deficiencies with compliance.

#### **Section 5. Enforcement**

- (a) Right to Cure. The Chapter does not provide a private right of action upon any person or entity to seek injunctive relief against the City or any employee unless that person or entity has first provided written notice to the City Manager by serving the City Clerk, regarding the specific alleged violations of this Chapter. If the alleged violation is substantiated and subsequently cured, a notice shall be posted in a conspicuous manner on the City's website that describes, to the extent permissible by law, the corrective measures taken to address the violation.
- ~~(a)(b)~~ Cause of Action. If a specific alleged violation is not remedied within 90 days of that written notice, a person or entity may Any violation of this Ordinance constitutes an injury, and any person may institute proceedings for injunctive relief, declaratory relief, or writ of mandate in any court of competent jurisdiction to enforce this Ordinance.
- ~~(b)(c)~~ (b) Damages and Civil Penalties. If the City is found liable in a cause of action brought by an individual under section (ab) above, for a violation that is the result of arbitrary or capricious action by the City or an employee or agent thereof in their official capacity, the City shall be liable for (1) the damages suffered by the plaintiff, if any, as determined by the court, and (2) a civil penalty no greater than \$5,000 per violation, as determined by the court. In determining the amount of the civil penalty, the court shall consider whether the violation was the result of arbitrary or capricious action by the City or an employee or agent thereof in his or her official capacity, and any other prior violations of this ordinance by the City department that committed the violation.
- ~~(e)(d)~~ (e) Attorney's Fees and Costs. A court shall award a plaintiff who prevails on a cause of action under subsection (a) reasonable attorney's fees and costs in an amount not to exceed \$15,000.



~~(d)~~(e) Limitations on Actions. Any person bringing an action pursuant to this ordinance must first file a claim with the City pursuant to Government Code 905 or any successor statute within four years of the alleged violation.

~~(e)~~(f) Any contracting Person or Entity knowingly or willingly supplying false information in violation of Section 3 (3)(c), shall be guilty of a misdemeanor and up to a \$1,000 fine.

**Section 6. Severability**

The provisions in this Ordinance are severable. If any part of provision of this Ordinance, or the application of this Ordinance to any person or circumstance, is held invalid, the remainder of this Ordinance, including the application of such part or provisions to other persons or circumstances, shall not be affected by such holding and shall continue to have force and effect.

**Section 7. Construction**

The provisions of this Ordinance are to be construed broadly to effectuate the purposes of this Ordinance.

**Section 8. Effective Date**

This Ordinance shall take effect on [DATE].

**REVISED  
AGENDA MATERIAL  
for Supplemental Packet 2**

**Meeting Date:** October 16<sup>th</sup>, 2018

**Item Number:** 21

**Item Description:** Adopt the Sanctuary Contracting Ordinance proposed by the Peace and Justice Commission

**Submitted by:** Councilmember Worthington

Add Councilmember Harrison as co-sponsor.

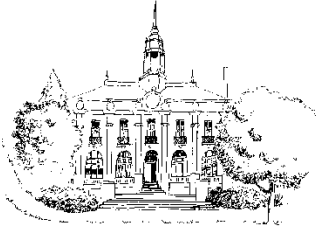

## Kriss Worthington

Councilmember, City of Berkeley, District 7  
2180 Milvia Street, 5<sup>th</sup> Floor, Berkeley, CA 94704  
PHONE 510-981-7170, FAX 510-981-7177,  
EMAIL [kworthington@cityofberkeley.info](mailto:kworthington@cityofberkeley.info)

### CONSENT CALENDAR

October 16, 2018

To: Honorable Mayor and Members of the City Council  
From: Councilmember [Cheryl Davila, Kate Harrison, and](#) Kriss Worthington  
Subject: Adopt the Sanctuary Contracting Ordinance proposed by the Peace and Justice Commission

#### RECOMMENDATION:

That the City Council adopt the attached Sanctuary Contracting Ordinance proposed by the Peace and Justice Commission. This ordinance prohibits the award of city contracts to vendors acting as ICE data brokers, or those providing extreme vetting services.

#### BACKGROUND:

The City Council has previously referred a draft ordinance to the Peace and Justice Commission, and the Commission has reviewed, amended, and recommended the adoption of this ordinance, by a vote of 5-0 with two absent members. This updated and refined version of the Sanctuary Contracting Ordinance by the Peace and Justice Commission would prohibit the award of city contracts to ICE vendors acting as "Data Brokers" or those who provide "Extreme Vetting" services. By adopting this ordinance, the City of Berkeley will protect the privacy, safety, dignity, and quality of life of the members of the Berkeley community, especially targeted immigrants and religious minorities. It is the duty of the City to uphold and promote values of inclusion and shared prosperity.

Here is a link to the Peace and Justice Commission Recommendation with track changes:  
<https://drive.google.com/file/d/1V9nY1BeWSbFOlgb7YF5opB4rkBKvBqd/view?usp=sharing>

#### FINANCIAL IMPLICATIONS:

Minimal.

#### ENVIRONMENTAL SUSTAINABILITY:

Consistent with Berkeley's Environmental Sustainability Goals and no negative impact.

#### CONTACT PERSON:

Councilmember Kriss Worthington 510-981-7170

ORDINANCE NO. -N.S.

BE IT ORDAINED by the Council of the City of Berkeley as follows:

**Section 1. Title**

This ordinance shall be known as the Sanctuary City Contracting Ordinance.

**Section 2. Definitions**

- 1) "City" means the City of Berkeley, California.
- 2) "Data Broker" (also commonly called information broker, information reseller, data aggregator, and information solution provider) means either of the following:
  - a) The collection of information, including personal information about consumers, from a wide variety of sources for the purposes of reselling such information to their customers, which include both private-sector businesses and government agencies;
  - b) The aggregation of data that was collected for another purpose from that for which it is ultimately used.
- 3) "Extreme Vetting" means data-mining, threat modeling, predictive risk analysis, or other similar services.
- 4) "ICE" means the United States Immigration and Customs Enforcement, and any subdivision thereof.
- 5) "Person or Entity" means any private natural person, corporation, institution, subsidiary, affiliate, or division under operating control of such person; the parent entities that have operating control over such person, and the subsidiaries, affiliates and divisions under operating control of such parent entity. Government entities and employees are expressly excluded from this definition.

**Section 3. Prohibition on Use of City Resources**

- 1) No officer, employee, department, board, commission, City Council, City Manager, or other entity of the City shall enter into a new, amended, or extended contract or agreement with any Person or Entity that provides ICE with any "Data Broker" or "Extreme Vetting" services, as defined herein, unless a waiver is granted based on a specific determination that no reasonable alternative exists, taking into consideration the following:
  - a) The intent and purpose of this ordinance;
  - b) The availability of alternative services, goods and equipment; and
  - c) Quantifiable additional costs resulting from use of available alternatives.

The following process shall be followed in considering a waiver: the City Manager or designee shall file a waiver request with the Peace and Justice Commission. The Commission shall weigh the above considerations and make a recommendation to the City Council. The Council shall make the final decision on granting the waiver.
- 2) All public works, construction bids, requests for information, requests for proposals, or any other solicitation issued by the City shall include notice of the prohibition listed above.
- 3) For the purpose of determining which Person or Entity provides ICE with Data Broker or Extreme Vetting services, the City Manager shall rely on:
  - a) Information published by reliable sources
  - b) Information released by public agencies
  - c) A declaration under the penalty of perjury executed by the Person or Entity, affirming that they do not provide Data Broker or Extreme Vetting services to ICE
  - d) Information submitted to the City Manager by any member of the public, and thereafter duly verified
- 4) Any Person or Entity identified as a supplier of Data Broker or Extreme Vetting services to ICE and potentially affected by this section shall be notified by the City Manager of the determination. Any such Person or Entity shall be entitled to a review of the

determination by appeal to the City Manager. Request for such review shall be made within thirty (30) days of notification, or seven (7) days of the date of a City solicitation or notice of a pending contract or purchase, of interest to the Person or Entity seeking review. Any Person or Entity vendor so identified may appeal the City Manager's determination to the City Council, within fifteen (15) days of the determination.

#### **Section 4. Investigation And Reporting**

- (a) The City Manager, or his or her designee, shall review compliance with Section 3. The City Manager may initiate and shall receive complaints regarding violations of Section 3. After investigating such complaints, the City Manager shall issue findings regarding any alleged violation. If the City Manager finds that a violation occurred, the City Manager shall, within 30 days of such finding, send a report of such finding to the City Council, the Mayor, and the head of any department involved in the violation or in which the violation occurred. All officers, employees, departments, boards, commissions, and other entities of the City shall cooperate with the City Manager in any investigation of a violation of Sections 3.
- (b) By April 1 of each year, each City department shall certify its compliance with this ordinance by written notice to the City Manager.
- (c) By May 1 of each year, the City Manager shall schedule and submit to the City Council a written, public report regarding compliance with Section 3 over the previous calendar year. At minimum, this report must (1) detail with specificity the steps taken to ensure compliance with Sections 3, (2) disclose any issues with compliance, including any violations or potential violations of this Ordinance, and (3) detail actions taken to cure any deficiencies with compliance.

#### **Section 5. Enforcement**

- (a) Cause of Action. Any violation of this Ordinance constitutes an injury, and any person may institute proceedings for injunctive relief, declaratory relief, or writ of mandate in any court of competent jurisdiction to enforce this Ordinance.
- (b) Damages and Civil Penalties. If the City is found liable in a cause of action brought by an individual under section (a) above, the City shall be liable for (1) the damages suffered by the plaintiff, if any, as determined by the court, and (2) a civil penalty no greater than \$5,000 per violation, as determined by the court. In determining the amount of the civil penalty, the court shall consider whether the violation was the result of arbitrary or capricious action by the City or an employee or agent thereof in his or her official capacity, and any other prior violations of this ordinance by the City department that committed the violation.
- (c) Attorney's Fees and Costs. A court shall award a plaintiff who prevails on a cause of action under subsection (a) reasonable attorney's fees and costs.
- (d) Limitations on Actions. Any person bringing an action pursuant to this ordinance must first file a claim with the City pursuant to Government Code 905 or any successor statute within four years of the alleged violation.
- (e) Any Person or Entity knowingly or willingly supplying false information in violation of Section 3 (3)(c), shall be guilty of a misdemeanor and up to a \$1,000 fine.

#### **Section 6. Severability**

The provisions in this Ordinance are severable. If any part of provision of this Ordinance, or the application of this Ordinance to any person or circumstance, is held invalid, the remainder of this Ordinance, including the application of such part or provisions to other persons or circumstances, shall not be affected by such holding and shall continue to have force and effect.

#### **Section 7. Construction**

The provisions of this Ordinance are to be construed broadly to effectuate the purposes of this Ordinance.

#### **Section 8. Effective Date**

This Ordinance shall take effect on [DATE].

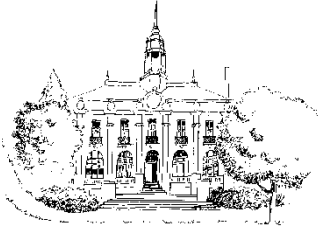

## Kriss Worthington

Councilmember, City of Berkeley, District 7  
2180 Milvia Street, 5<sup>th</sup> Floor, Berkeley, CA 94704  
PHONE 510-981-7170, FAX 510-981-7177,  
EMAIL [kworthington@cityofberkeley.info](mailto:kworthington@cityofberkeley.info)

### ACTION CALENDAR

February 26, 2019

*(Continued from January 29, 2019)*

To: Honorable Mayor and Members of the City Council  
From: Councilmember Kriss Worthington, Councilmember Cheryl Davila, and  
Councilmember Ben Bartlett

Subject: Adopt the Sanctuary Contracting Ordinance proposed by the Peace and Justice  
Commission

#### RECOMMENDATION:

That the City Council adopt the attached Sanctuary Contracting Ordinance proposed by the Peace and Justice Commission. This ordinance prohibits the award of city contracts to vendors acting as ICE data brokers, or those providing extreme vetting services.

#### BACKGROUND:

The City Council has previously referred a draft ordinance to the Peace and Justice Commission, and the Commission has reviewed, amended, and recommended the adoption of this ordinance, by a vote of 5-0 with two absent members. This updated and refined version of the Sanctuary Contracting Ordinance by the Peace and Justice Commission would prohibit the award of city contracts to ICE vendors acting as "Data Brokers" or those who provide "Extreme Vetting" services. By adopting this ordinance, the City of Berkeley will protect the privacy, safety, dignity, and quality of life of the members of the Berkeley community, especially targeted immigrants and religious minorities. It is the duty of the city to uphold and promote values of inclusion and shared prosperity.

Here is a link to the Peace and Justice Commission Recommendation with track changes:  
<https://drive.google.com/file/d/1V9nY1BeWSbFOlgb7YF5opB4rlkBKvBqd/view?usp=sharing>

#### FINANCIAL IMPLICATIONS:

Minimal.

#### ENVIRONMENTAL SUSTAINABILITY:

Consistent with Berkeley's Environmental Sustainability Goals and no negative impact.

#### CONTACT PERSON:

Councilmember Kriss Worthington 510-981-7170

## ORDINANCE NO. -N.S.

BE IT ORDAINED by the Council of the City of Berkeley as follows:

**Section 1. Title**

This ordinance shall be known as the Sanctuary City Contracting Ordinance.

**Section 2. Definitions**

- 1) "City" means the City of Berkeley, California.
- 2) "Data Broker" (also commonly called information broker, information reseller, data aggregator, and information solution provider) means either of the following:
  - a) The collection of information, including personal information about consumers, from a wide variety of sources for the purposes of reselling such information to their customers, which include both private-sector businesses and government agencies;
  - b) The aggregation of data that was collected for another purpose from that for which it is ultimately used.
- 3) "Extreme Vetting" means data-mining, threat modeling, predictive risk analysis, or other similar services.
- 4) "ICE" means the United States Immigration and Customs Enforcement, and any subdivision thereof.
- 5) "Person or Entity" means any private natural person, corporation, institution, subsidiary, affiliate, or division under operating control of such person; the parent entities that have operating control over such person, and the subsidiaries, affiliates and divisions under operating control of such parent entity. Government entities and employees are expressly excluded from this definition.

**Section 3. Prohibition on Use of City Resources**

- 1) No officer, employee, department, board, commission, City Council, City Manager, or other entity of the City shall enter into a new, amended, or extended contract or agreement with any Person or Entity that provides ICE with any "Data Broker" or "Extreme Vetting" services, as defined herein, unless a waiver is granted based on a specific determination that no reasonable alternative exists, taking into consideration the following:
  - a) The intent and purpose of this ordinance;
  - b) The availability of alternative services, goods and equipment; and
  - c) Quantifiable additional costs resulting from use of available alternatives.

The following process shall be followed in considering a waiver: the City Manager or designee shall file a waiver request with the Peace and Justice Commission. The Commission shall weigh the above considerations and make a recommendation to the City Council. The Council shall make the final decision on granting the waiver.
- 2) All public works, construction bids, requests for information, requests for proposals, or any other solicitation issued by the City shall include notice of the prohibition listed above.
- 3) For the purpose of determining which Person or Entity provides ICE with Data Broker or Extreme Vetting services, the City Manager shall rely on:
  - a) Information published by reliable sources
  - b) Information released by public agencies
  - c) A declaration under the penalty of perjury executed by the Person or Entity, affirming that they do not provide Data Broker or Extreme Vetting services to ICE
  - d) Information submitted to the City Manager by any member of the public, and



thereafter duly verified

- 4) Any Person or Entity identified as a supplier of Data Broker or Extreme Vetting services to ICE and potentially affected by this section shall be notified by the City Manager of the determination. Any such Person or Entity shall be entitled to a review of the determination by appeal to the City Manager. Request for such review shall be made within thirty (30) days of notification, or seven (7) days of the date of a City solicitation or notice of a pending contract or purchase, of interest to the Person or Entity seeking review. Any Person or Entity vendor so identified may appeal the City Manager's determination to the City Council, within fifteen (15) days of the determination.

#### **Section 4. Investigation And Reporting**

- (a) The City Manager, or his or her designee, shall review compliance with Section 3. The City Manager may initiate and shall receive complaints regarding violations of Section 3. After investigating such complaints, the City Manager shall issue findings regarding any alleged violation. If the City Manager finds that a violation occurred, the City Manager shall, within 30 days of such finding, send a report of such finding to the City Council, the Mayor, and the head of any department involved in the violation or in which the violation occurred. All officers, employees, departments, boards, commissions, and other entities of the City shall cooperate with the City Manager in any investigation of a violation of Sections 3.
- (b) By April 1 of each year, each City department shall certify its compliance with this ordinance by written notice to the City Manager.
- (c) By May 1 of each year, the City Manager shall schedule and submit to the City Council a written, public report regarding compliance with Section 3 over the previous calendar year. At minimum, this report must (1) detail with specificity the steps taken to ensure compliance with Sections 3, (2) disclose any issues with compliance, including any violations or potential violations of this Ordinance, and (3) detail actions taken to cure any deficiencies with compliance.

#### **Section 5. Enforcement**

- (a) Cause of Action. Any violation of this Ordinance constitutes an injury, and any person may institute proceedings for injunctive relief, declaratory relief, or writ of mandate in any court of competent jurisdiction to enforce this Ordinance.
- (b) Damages and Civil Penalties. If the City is found liable in a cause of action brought by an individual under section (a) above, the City shall be liable for (1) the damages suffered by the plaintiff, if any, as determined by the court, and (2) a civil penalty no greater than \$5,000 per violation, as determined by the court. In determining the amount of the civil penalty, the court shall consider whether the violation was the result of arbitrary or capricious action by the City or an employee or agent thereof in his or her official capacity, and any other prior violations of this ordinance by the City department that committed the violation.
- (c) Attorney's Fees and Costs. A court shall award a plaintiff who prevails on a cause of action under subsection (a) reasonable attorney's fees and costs.
- (d) Limitations on Actions. Any person bringing an action pursuant to this ordinance must first file a claim with the City pursuant to Government Code 905 or any successor statute within four years of the alleged violation.
- (e) Any Person or Entity knowingly or willingly supplying false information in violation of Section 3 (3)(c), shall be guilty of a misdemeanor and up to a \$1,000 fine.

#### **Section 6. Severability**

The provisions in this Ordinance are severable. If any part of provision of this Ordinance, or the application of this Ordinance to any person or circumstance, is held invalid, the remainder of this Ordinance, including the application of such part or provisions to other persons or circumstances, shall not be affected by such holding and shall continue to have force and effect.

**Section 7. Construction**

The provisions of this Ordinance are to be construed broadly to effectuate the purposes of this Ordinance.

**Section 8. Effective Date**

This Ordinance shall take effect on [DATE].



Kate Harrison  
Councilmember District 4

CONSENT CALENDAR  
April 23<sup>rd</sup>, 2019

To: Honorable Mayor and Members of the City Council

From: Councilmembers Kate Harrison, Cheryl Davila, and Rigel Robinson, and Mayor Arreguin

Subject: Resolution in Support of a Public Bank

RECOMMENDATION

Adopt a resolution affirming Berkeley's support for public banking and send that resolution to Governor Newsom, Senator Skinner, and Assemblymember Wicks urging state legislation to enable local agencies to create public banks.

BACKGROUND

Public banks offer a way for governmental agencies such as cities, counties and states, as well as some organizations such as pension funds, to invest their funds in an institution that allows the investing organizations to avoid the high financial costs of dealing with private sector for-profit banks. Because public banks are created in the public interest rather than to maximize profit, public banks also generate income from their investments that can be re-invested in public benefit projects such as affordable housing, public transportation, and social programs. A public bank could decide to have no investment in fossil fuels, weapons, or tobacco in line with the priorities set by the Peace and Justice Commission. It could adhere to principles of economic, racial and environmental justice.

Public banks are run by qualified bankers serving a public mission and these banks partner with and support rather than compete with local banks. The Bank of North Dakota, a public bank which was founded in 1919, successfully weathered the last recession without the bailouts that went to Wall Street banks, and has provided hundreds of millions of dollars to North Dakota's treasury over the years.

Public Bank of the East Bay (PBEB) is an organization founded in August 2016 to advocate for a public bank for Alameda and West Contra Costa Counties. In 2018, the City of Oakland spearheaded a study on the feasibility of an East Bay public bank, using contributions from the City of Berkeley and from Alameda County. The study deemed a public bank feasible, though still not legal under state law. We urge our representatives and governor to support legislation to allow local jurisdictions to create public banks through charter processes.

FISCAL IMPACTS OF RECOMMENDATION

Because public banks invest according to common need, rather than private profit, the dividends from a public bank may reduce pressure on the General Fund.

ENVIRONMENTAL SUSTAINABILITY

Private banks often invest in fossil fuel capital projects such as the Dakota Access Pipeline. Public banking, through fossil fuel divestment, promote environmental sustainability.

CONTACT PERSON

Kate Harrison, Berkeley City Councilmember, (510) 981-7140

ATTACHMENTS

1: Resolution

## RESOLUTION NO. ##,###-N.S.

## RESOLUTION IN SUPPORT OF A PUBLIC BANK

WHEREAS, a public bank is defined as a financial institution owned by one or more public entities such as a state, city, or county; and

WHEREAS, public banks are created in the public interest rather than to maximize profit, and income from their investments can be re-invested in public benefit programs; and

WHEREAS, a public bank can decide to have no investments in industries that run contrary to Berkeley's values, such as fossil fuels, weapons, or tobacco; and

WHEREAS, a bank owned by the Cities of Oakland, Richmond, and Berkeley and the County of Alameda will allow those jurisdictions to have more local control, transparency, and self-determination, and allow us to invest in public goods such as affordable housing, loans to low-income households, public transit, infrastructure, and renewable energy; and

WHEREAS, public banks are run by qualified bankers serving a public mission and these banks partner with and support local banks and credit unions; and

WHEREAS, the Bank of North Dakota, a public bank founded in 1919, is extremely successful and avoided a foreclosure crisis in 2008 because it did not issue risky mortgages; and

WHEREAS, in September 2018, the Oakland City Council accepted the East Bay Public Bank's Feasibility Study; and

WHEREAS, the State of California's lack of a public-banking charter option imposes an obstacle to efforts to explore a public bank and prevents public banks from becoming operational; and

WHEREAS, Assemblymembers Chiu and Santiago, with the support of the California Public Banking Alliance, have introduced AB 857 in the state legislature creating a uniform regulatory framework for municipal and regional public banks, which would allow for public banking charters under the regulatory oversight of the California Department of Business Oversight;

NOW THEREFORE, BE IT RESOLVED that the Council of the City of Berkeley supports the continued efforts to create and operationalize the East Bay Public Bank; and

BE IT FURTHER RESOLVED that the Council of the City of Berkeley urges the California state legislature to enact legislation amending the Government Code to enable local agencies to create public banks regulated by the Department of Business Oversight; and

BE IT FURTHER RESOLVED that copies of this Resolution will be sent to Governor Gavin Newsom, Senator Nancy Skinner, and Assemblymember Buffy Wicks.





Susan Wengraf  
Councilmember District 6

CONSENT CALENDAR  
April 23, 2019

To: Honorable Mayor and Members of the City Council

From: Councilmember Susan Wengraf, Mayor Arreguin & Councilmembers Hahn & Bartlett

Subject: Letters In Support of SB 54 (Allen) and AB 1080 (Gonzalez)

RECOMMENDATION:

Send a letter of support for SB 54 (Allen) and AB 1080 (Gonzalez) to Senator Ben Allen and Assemblywoman Lorena Gonzalez with copies to Senator Skinner, Assembly Member Wicks and Governor Newsom

FINANCIAL IMPLICATIONS:

None

BACKGROUND:

SB 54 and AB 1080 will ensure that California is on the forefront of reducing plastic pollution from single use packaging and products. Both bills set goals to reduce plastic waste from packaging and product sources.

Single use plastic packaging in California generates tons of non-recyclable and non-compostable waste, impacting our health and environment. Packaging products are designed to be used only once and then discarded. Nearly every piece of plastic ever produced still exists in our environment. It never decomposes. As the plastic breaks up into smaller and smaller pieces, the fragments contaminate the soil, food and drinking water.

Currently, less than 9% of plastics are recycled and that percentage is dropping as China's National Sword and policies in other countries restrict the foreign waste that they accept. These materials are piling up in recycling centers, being sent to the landfill or shipped to illegal facilities in South East Asia where they are most likely incinerated.

Producers must take responsibility for reducing waste and designing packaging and products that will not harm our environment. As the fifth largest economy in the world, California should lead in finding solutions to the growing plastic pollution crisis.

ENVIRONMENTAL SUSTAINABILITY:

Support of SB 54 and AB 1080 is in complete harmony with the goals of our Climate Action Plan.

CONTACT PERSON

Councilmember Susan Wengraf

Council District 6

510-981-7160

Attachments:

- 1: [SB 54](#)
2. [AB 1080](#)
3. Letter of support for SB 54
4. Letter of support for AB 1080



CALIFORNIA LEGISLATURE— 2019–2020 REGULAR SESSION

**SENATE BILL**

**No. 54**

---

**Introduced by Senators Allen, Skinner, Stern, and Wiener  
(Principal coauthor: Assembly Member Gonzalez)**

**December 11, 2018**

---

An act to add Chapter 3 (commencing with Section 42040) to Part 3 of Division 30 of the Public Resources Code, relating to solid waste.

**LEGISLATIVE COUNSEL'S DIGEST**

SB 54, as amended, Allen. California Circular Economy and Plastic Pollution Reduction Act.

The California Integrated Waste Management Act of 1989, administered by the Department of Resources Recycling and Recovery, generally regulates the disposal, management, and recycling of solid waste, including, among other solid waste, single-use plastic straws.

The Sustainable Packaging for the State of California Act of 2018 prohibits a food service facility located in a state-owned facility, operating on or acting as a concessionaire on state property, or under contract to provide food service to a state agency from dispensing prepared food using a type of food service packaging unless the type of food service packaging is on a list that the department publishes and maintains on its internet website that contains types of approved food service packaging that are reusable, recyclable, or compostable.

Existing law makes a legislative declaration that it is the policy goal of the state that not less than 75% of solid waste generated be source reduced, recycled, or composted by 2020.

This bill would establish the California Circular Economy and Plastic Pollution Reduction Act, which would require the department, in consultation with the State Water Resources Control Board and the

Ocean Protection Council, to adopt regulations to source reduce and recycle 75% of single-use packaging and products sold or distributed in California by 2030. The bill would require the department to adopt regulations to accomplish that requirement, including, among others, regulations to require businesses to source reduce, to the maximum extent feasible, single-use packaging and products, to recycle, and require businesses to source reduce, at least 75% of single-use plastic packaging and products by 2030, and to require that all single-use packaging and products distributed or sold in California are recyclable or compostable on and after 2030. The bill would require the department, on or before January 1, 2021, to prepare and approve a scoping plan to set a baseline for and achieve those reduction and recycling requirements.

The bill would require the department to develop criteria to determine which types of single-use packaging or products are reusable, recyclable, or compostable. The bill would require local governments, solid waste facilities, recycling facilities, and composting facilities to provide information requested by the department for purposes of developing that criteria. By imposing additional duties on local governments, the bill would impose a state-mandated local program.

The bill would require a manufacturer of single-use plastic packaging or products sold or distributed in California to demonstrate a recycling rate of not less than 20% on and after January 1, 2022, and not less than 40% on and after January 1, 2026, as a condition of sale, and would authorize the department to impose a higher recycling rate as a condition of sale, as specified.

The California Constitution requires the state to reimburse local agencies and school districts for certain costs mandated by the state. Statutory provisions establish procedures for making that reimbursement. This bill would provide that, if the Commission on State Mandates determines that the bill contains costs mandated by the state, reimbursement for those costs shall be made pursuant to the statutory provisions noted above.

#### DIGEST KEY

Vote: majority Appropriation: no Fiscal Committee: yes Local Program: yes

CALIFORNIA LEGISLATURE— 2019–2020 REGULAR SESSION

**ASSEMBLY BILL**

**No. 1080**

---

**Introduced by Assembly Members Gonzalez, *Calderon*, Friedman, and Ting**  
**(Principal coauthor: Senator Allen)**  
**~~(Coauthor: Assembly Member Boerner Horvath)~~ (Coauthors: Assembly Members**  
***Boerner Horvath and McCarty*)**  
**(Coauthors: Senators Skinner, Stern, and Wiener)**

**February 21, 2019**

---

An act to add Chapter 3 (commencing with Section 42040) to Part 3 of Division 30 of the Public Resources Code, relating to solid waste.

**LEGISLATIVE COUNSEL'S DIGEST**

AB 1080, as amended, Gonzalez. California Circular Economy and Plastic Pollution Reduction Act. The California Integrated Waste Management Act of 1989, administered by the Department of Resources Recycling and Recovery, generally regulates the disposal, management, and recycling of solid waste, including, among other solid waste, single-use plastic straws. The Sustainable Packaging for the State of California Act of 2018 prohibits a food service facility located in a state-owned facility, operating on or acting as a concessionaire on state property, or under contract to provide food service to a state agency from dispensing prepared food using a type of food service packaging unless the type of food service packaging is on a list that the department publishes and maintains on its internet website that contains types of approved food service packaging that are reusable, recyclable, or compostable.

Existing law makes a legislative declaration that it is the policy goal of the state that not less than 75% of solid waste generated be source reduced, recycled, or composted by 2020.

This bill would establish the California Circular Economy and Plastic Pollution Reduction Act, which would require the department, in consultation with the State Water Resources Control Board and the Ocean Protection Council, to adopt regulations to source reduce and recycle 75% of single-use packaging and products sold or distributed in California by 2030. The bill would require the department to adopt regulations to accomplish that requirement, including, among others, regulations to *require businesses to* source reduce, to the maximum extent feasible, single-use packaging and products, to *recycle, and require businesses to* source ~~reduce or recycle~~ *reduce*, at least 75% of single-use plastic packaging and products by 2030, and to require that all single-use packaging and products distributed or sold in California are recyclable or compostable on and after 2030. The bill would require the department, on or before January 1, 2021, to prepare and approve a scoping plan to set a baseline for and achieve those reduction and recycling requirements.

The bill would require the department to develop criteria to determine which types of single-use packaging or products are reusable, recyclable, or compostable. The bill would require local governments, solid waste facilities, recycling facilities, and composting facilities to provide information requested by the department for purposes of developing that criteria. By imposing additional duties on local governments, the bill would impose a state-mandated local program.

The bill would require a manufacturer of single-use plastic packaging or products sold or distributed in California to demonstrate a recycling rate of not less than 20% on and after January 1, 2022, and not less than 40% on and after January 1, 2026, as a condition of sale, and would authorize the department to impose a higher recycling rate as a condition of sale, as specified.

The California Constitution requires the state to reimburse local agencies and school districts for certain costs mandated by the state. Statutory provisions establish procedures for making that reimbursement. This bill would provide that, if the Commission on State Mandates determines that the bill contains costs mandated by the state, reimbursement for those costs shall be made pursuant to the statutory provisions noted above.

#### DIGEST KEY

Vote: majority Appropriation: no Fiscal Committee: yes Local Program: yes

April 23, 2019

The Honorable Ben Allen  
California State Senator  
State Capitol, Room 4076  
Sacramento, CA 95814

**RE: S.B. 54 (Allen): California Circular Economy and Plastic Pollution Reduction Act  
Support from the Berkeley City Council**

Dear Senator Allen:

On behalf of the Berkeley City Council, I want to express Berkeley's strongly support of S.B. 54. The City Council thanks you for initiating legislation to reduce single use plastic waste from packaging and product sources. S.B. 54 works in harmony with Berkeley's Climate Action Plan goals.

Single use plastic packaging in California generates tons of non-recyclable and non-compostable waste, impacting our health and environment. Packaging products are designed to be used only once and then discarded. Nearly every piece of plastic ever produced still exists in our environment. It never decomposes. As the plastic breaks up into smaller and smaller pieces, the fragments contaminate the soil, food and drinking water.

Currently, less than 9% of plastics are recycled and that percentage is dropping as China's National Sword and policies in other countries restrict the foreign waste that they accept. These materials are piling up in recycling centers, being sent to the landfill or shipped to illegal facilities in South East Asia where they are most likely incinerated.

The City of Berkeley is in full support of mandating that producers must take responsibility for reducing waste and designing packaging and products that will not harm our environment. As the fifth largest economy in the world, California should lead in finding solutions to the growing plastic pollution crisis.

I applaud you for your leadership in creating this legislation!

Susan Wengraf  
Vice Mayor  
City of Berkeley

CC: Senator Nancy Skinner, Assembly Member Buffy Wicks, Governor Gavin Newsom

April 23, 2019

The Honorable Lorena Gonzalez  
California Assembly Member  
State Capitol  
P.O. Box 942849  
Sacramento, CA 94249-0080

**RE: A.B 1080 (Gonzalez): California Circular Economy and Plastic Pollution Reduction Act  
Support from the Berkeley City Council**

Dear Assembly Member Gonzalez:

On behalf of the Berkeley City Council, I want to express Berkeley's strongly support of A.B. 1080. The City Council thanks you for initiating legislation to reduce single use plastic waste from packaging and product sources. A.B. 1080 works in harmony with Berkeley's Climate Action Plan goals.

Single use plastic packaging in California generates tons of non-recyclable and non-compostable waste, impacting our health and environment. Packaging products are designed to be used only once and then discarded. Nearly every piece of plastic ever produced still exists in our environment. It never decomposes. As the plastic breaks up into smaller and smaller pieces, the fragments contaminate the soil, food and drinking water.

Currently, less than 9% of plastics are recycled and that percentage is dropping as China's National Sword and policies in other countries restrict the foreign waste that they accept. These materials are piling up in recycling centers, being sent to the landfill or shipped to illegal facilities in South East Asia where they are most likely incinerated.

The City of Berkeley is in full support of mandating that producers must take responsibility for reducing waste and designing packaging and products that will not harm our environment. As the fifth largest economy in the world, California should lead in finding solutions to the growing plastic pollution crisis.

I applaud you for your leadership in creating this legislation!

Susan Wengraf  
Vice Mayor  
City of Berkeley

CC: Senator Skinner, Representative Wicks, Governor Newsom



Susan Wengraf  
Councilmember District 6

CONSENT CALENDAR  
April 23, 2019

To: Honorable Mayor and Members of the City Council  
From: Councilmember Wengraf, Mayor Arreguin, and Councilmembers Bartlett and Hahn  
Subject: Co-Sponsor the Screening of "Near Normal Man"

RECOMMENDATION:

That the City of Berkeley become an official co-sponsor of the screening and discussion of "Near Normal Man" on April 29<sup>th</sup> at Berkeley City College

FINANCIAL IMPLICATIONS:

None

BACKGROUND

Ben Stern, who survived two ghettos, nine concentration camps and two death marches, faced Nazi's a second time 30 years later in 1978, when the Nazis planned a march in Skokie, Illinois. Stern sparked a fierce public battle opposing the Nazis and the ACLU, which defended the Nazis' First Amendment rights to free speech. Skokie, a community heavily populated with Holocaust survivors – were urged to "stay home, close the shades and let it pass." Stern refused and instead built a national following with more than 750,000 people of all backgrounds, religions and races who signed petitions to protest the Nazi rally. When the Illinois Supreme Court affirmed their right to march in Skokie, more than 60,000 people pledged to show up and counter-demonstrate. Only then did the Nazis cancel their march.

Now, 40 years later, Ben Stern, living in Berkeley, California, and subject of the award-winning documentary film, "Near Normal Man", will speak out against Hate Speech again and invoke everyone to use their Freedom of Speech better and louder in resistance to growing hatred, rage, violence and mass murders in our country and world. For Stern, who defied the Nazis three times in one lifetime, this conversation with the audience, many who are also immigrants, will offer a compelling reminder of the dangers in our country today.

ENVIRONMENTAL SUSTAINABILITY

N/A

CONTACT PERSON:

Councilmember Wengraf                      Council District 6                      510-981-7160

Attachments: Flyer



Near Normal Man, An award-winning, documentary film of a deeply personal story about racism and genocide, surviving, and remaining human

One young man defied the forces that sought to destroy him, then sparked a fierce public battle 30 years later, for justice in America; leading with courage, kindness and hope.

## Film Screening & Real Conversation

**Q & A With  
Ben Stern**

**Holocaust Survivor and Social Justice Activist  
2017 James Joyce Award Winner**

**and**

**Charlene Stern  
Producer/Director**

**Monday, April 29, 2019**

**5:30 pm**

**Berkeley City College Auditorium**

**Refreshments will be provided**

**[www.nearnormalman.org](http://www.nearnormalman.org)**



**Berkeley City College  
2050 Center St. Berkeley, A 94704**

**For questions, please email  
[bcc-campuslife@peralta.edu](mailto:bcc-campuslife@peralta.edu)**



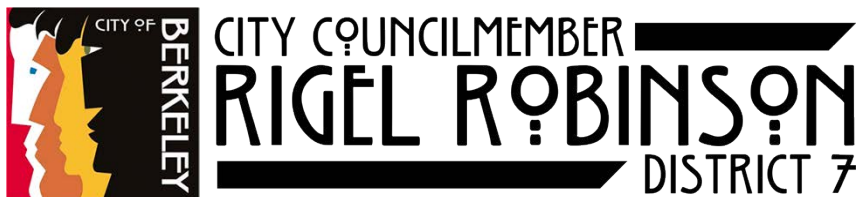

CONSENT CALENDAR  
April 23, 2019

To: Honorable Mayor and Members of the City Council  
 From: Councilmembers Rigel Robinson, Cheryl Davila, and Ben Bartlett  
 Subject: Support for SB 188 (Hairstyle Anti-Discrimination Law)

### RECOMMENDATION

Send a letter to Senator Mitchell, Senator Skinner, and Assemblymember Wicks supporting SB 188, which would amend the California Fair Employment and Housing Act to prohibit racial discrimination on the basis of hairstyle.

### BACKGROUND

Under the 1959 California Fair Employment and Housing Act (FEHA), it is unlawful to engage in discrimination on the basis of certain protected characteristics in the workplace or housing sector. Protected categories include an individual's actual or perceived race, religious beliefs, disability status, marital status, sex, or sexual orientation.

SB 188 (Mitchell) would amend FEHA in order to "provide that the definition of race also include traits historically associated with race, including, but not limited to, hair texture and protective hairstyles, and would define protective hairstyles for purposes of these provisions." In other words, it eliminates forms of disparate impact discrimination that occur in appearance and grooming codes, and clarifies that individuals of all races have the right to maintain natural hair.

The mission of SB 188 is consistent with local goals, as stated in Berkeley Municipal Code Section 1.22.010, declaring "the City of Berkeley shall promote: (1) Higher standards of living, full employment, and conditions of economic and social progress and development; (2) Solutions of local economic, social, health and related problems; and regional cultural and educational cooperation; and (3) Universal respect for, and observance of human rights and fundamental freedoms for all without distinction as to race, sex, language or religion."

This proposed FEHA amendment is a crucial step for California to take towards eliminating racial discrimination in all its forms.

### FINANCIAL IMPLICATIONS

None.

### ENVIRONMENTAL SUSTAINABILITY

No impact.

[Title of Report]

CONSENT CALENDAR  
April 23, 2019

CONTACT PERSON

Councilmember Rigel Robinson, (510) 981-7170  
Mars Svec-Burdick, Intern

Attachments:

1: Letter of support

2: Bill Text - SB 188:

[http://leginfo.legislature.ca.gov/faces/billNavClient.xhtml?bill\\_id=201920200SB188](http://leginfo.legislature.ca.gov/faces/billNavClient.xhtml?bill_id=201920200SB188)

April 23, 2019

The Honorable Holly Mitchell  
California State Senate  
State Capitol, Room 5050  
Sacramento, CA 95814

RE: SB 188, Mitchell, Hairstyle Anti-Discrimination Law  
Support from the Berkeley City Council

Dear Senator Mitchell:

The Berkeley City Council would like to convey support for your bill SB 188, regarding protections against racial discrimination on the basis of hairstyle.

As proposed, this bill addresses ongoing discrimination faced by racial minority groups in the workplace and housing sector. Current law does not go far enough to prevent disparate impact discrimination in appearance and grooming codes, wherein hair styling rules may permit members of some groups to wear their hair naturally, but requires others to undergo more extensive procedures. SB 188 is an important and necessary reform because it closes this loophole, by amending the 1959 California Fair Employment and Housing Act (FEHA) to include natural hairstyle and other inherited personal traits under the protected category of race.

This proposed FEHA amendment is consistent with the City of Berkeley's mission to observe universal human rights without distinction according to race or nationality, and represents a crucial step towards ensuring workplace and housing equality for all Californians.

Thank you for introducing this important piece of legislation, and striving to eliminate racial discrimination in all its forms.

Sincerely,

Berkeley City Council

CC: Senator Nancy Skinner  
Assembly Member Buffy Wicks





CITY COUNCILMEMBER  
**RIGEL ROBINSON**  
 DISTRICT 7

CONSENT CALENDAR  
 April 23, 2019

To: Honorable Mayor and Members of the City Council  
 From: Councilmembers Rigel Robinson, Ben Bartlett, and Kate Harrison  
 Subject: Support for ACA-1: Local Government Financing: Affordable Housing and Public Infrastructure: Voter Approval

RECOMMENDATION

Adopt a resolution supporting ACA-1, which would allow local governments to raise property taxes to fund bonds for the purposes of financing public infrastructure and affordable housing projects, as well as reducing the required vote threshold to authorize certain local special taxes for the purpose of funding public infrastructure and affordable housing. Copies of the resolution to be sent to Senator Nancy Skinner, Assemblymember Buffy Wicks, and Assemblymember Aguiar-Curry.

BACKGROUND

Introduced by Assemblywoman Aguiar-Curry on December 3, 2018, ACA 1 would significantly increase the ability of local governments to fund badly needed public infrastructure and affordable housing projects. If adopted and passed by the voters, it would authorize local governments to raise property taxes beyond the 1% maximum established by Prop 13 for the purposes of funding bond payments to finance public infrastructure and affordable housing projects, as well as reducing the required vote threshold to pass specified types of local taxes to fund the same types of projects.

Since the passage of Proposition 13 in 1978, which limits property tax to 1%, local governments have had to find new ways to generate revenue, resulting in extensive funding loss. While overall California local revenue has slightly increased since 1978, municipal governments in California have shown much less growth than in other areas of the country.<sup>1</sup>

Affordable housing is a critical need across the state, and public infrastructure has been allowed to fall into disrepair. This measure would empower local governments with the tools necessary to address both these crises.

The attached resolution states the City of Berkeley's endorsement of the bill and subsequent ballot measure. Copies of the resolution will be sent to Senator Nancy

---

1

[https://lao.ca.gov/publications/report/3497#What\\_Happened\\_to\\_Local\\_Government\\_Revenues\\_After\\_Proposition.A013.3F](https://lao.ca.gov/publications/report/3497#What_Happened_to_Local_Government_Revenues_After_Proposition_A013.3F)

Skinner, Assemblymember Buffy Wicks, and the bill's author, Assemblywoman Aguiar-Curry.

FINANCIAL IMPLICATIONS

None.

ENVIRONMENTAL SUSTAINABILITY

Consistent with the City's climate and environmental goals.

CONTACT PERSON

Councilmember Rigel Robinson, (510) 981-7170  
Jilly Choi, Intern

Attachments:

1: Resolution

2: Bill Text – ACA 1:

[https://leginfo.legislature.ca.gov/faces/billTextClient.xhtml?bill\\_id=201920200ACA1](https://leginfo.legislature.ca.gov/faces/billTextClient.xhtml?bill_id=201920200ACA1)

RESOLUTION NO. ##,###-N.S.

RESOLUTION IN SUPPORT OF ACA-1

WHEREAS the State of California faces a housing affordability crisis that demands government investment, and;

WHEREAS, restricted financing has allowed the State's public infrastructure to fall into severe disrepair, and;

WHEREAS, the passage of Proposition 13 has devastated the ability of local governments to finance the public projects badly needed to address these crises, and;

WHEREAS, ACA-1 gives local governments the tools they need to build affordable housing and repair public infrastructure.

NOW THEREFORE, BE IT RESOLVED that the City of Berkeley hereby endorses ACA-1 and the ballot measure that will result from its passage; and

BE IT FURTHER RESOLVED that the City of Berkeley may be listed as a supporter of said ballot measure by the official proponents of the measure; and

BE IT FURTHER RESOLVED that copies of this resolution will be sent to Senator Nancy Skinner, Assemblymember Buffy Wicks, and Assemblymember Aguiar-Curry.





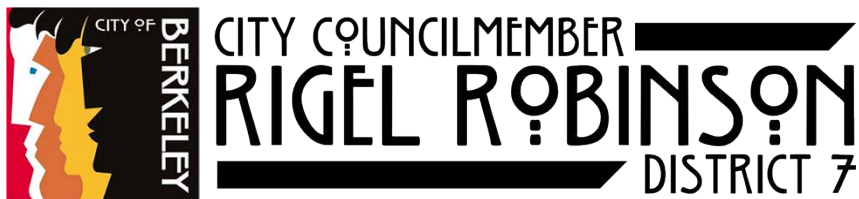

CONSENT CALENDAR  
April 23, 2019

To: Honorable Mayor and Members of the City Council  
 From: Councilmembers Rigel Robinson and Kate Harrison  
 Subject: Support for AB 273 and AB 44: Prohibit Fur Trapping and Sales

### RECOMMENDATION

Adopt a resolution supporting Fish and Game Code amendment AB 273, which prohibits the trapping of fur-bearing and nongame mammals for recreational or commercial purposes, and AB 44, which amends the Fish and Game Code to prohibit the sale of fur products statewide.

### BACKGROUND

Introduced on January 24, 2019 by Assemblymember Lorena Gonzalez, the Wildlife Protection Act of 2019 (AB 273) proposes a series of amendments to the Fish and Game Code. By limiting the distribution of trapping licenses and eliminating fur dealer and fur agent licenses entirely, the Act seeks to combat the exploitation of native California mammals.

Introduced on December 03, 2018 by Assemblymember Laura Friedman, the Fur Products Prohibition Act (AB 44) proposes a prohibition on the manufacture or sale of fur products throughout the state. Imposing this ban would allow California to take a lead on this issue nationally, by becoming the first state to do so. As the second of several prominent California cities to have already taken this step, the City of Berkeley should support the proposal.

AB 273 and AB 44 both reflect the majority support for animal rights expressed by state voters at the ballot box, most recently in the 2018 passage of Proposition 12, which set humane confinement standards for fowl and livestock.

The attached letters state the City of Berkeley's endorsement of the proposed Code amendments. Copies will be sent to Senator Nancy Skinner, Assemblymember Buffy Wicks, and the bills' authors, Assemblymember Lorena Gonzalez and Assemblymember Laura Friedman.

### FINANCIAL IMPLICATIONS

None.

### ENVIRONMENTAL SUSTAINABILITY

Consistent with the City's environmental goals.

CONTACT PERSON

Councilmember Rigel Robinson, (510) 981-7170  
Mars Svec-Burdick, Intern

Attachments:

1: Letter of support to Assemblymember Lorena Gonzalez

2: Letter of support to Assemblymember Laura Friedman

3: Bill Text -

[https://leginfo.legislature.ca.gov/faces/billNavClient.xhtml?bill\\_id=201920200AB273](https://leginfo.legislature.ca.gov/faces/billNavClient.xhtml?bill_id=201920200AB273)

4: Bill Text -

[https://leginfo.legislature.ca.gov/faces/billNavClient.xhtml?bill\\_id=201920200AB44](https://leginfo.legislature.ca.gov/faces/billNavClient.xhtml?bill_id=201920200AB44)

April 23, 2019

The Honorable Lorena Gonzalez  
Member of the Assembly  
State Capitol, Room 2114  
Sacramento, CA 95814

Re: AB 273 (Gonzales) – Wildlife Protection Act  
Support from the Berkeley City Council

Dear Assemblymember Gonzalez,

The Berkeley City Council would like to convey its full support for your bill AB 273, which seeks to protect native species by limiting the trapping of animals statewide.

The production process of commercial fur products entails varying and extensive forms of recognized animal cruelty, in addition to causing the decline of native species populations. Fur trade industry values are inconsistent with the standards of humane, sustainable, and dignified treatment of commercially used fur-bearing mammals.

Under current law, the manufacture and sale of fur is already prohibited in major metropolitan areas of the state, reflecting the electorate's withdrawal of support from the practice. The Wildlife Protection Act of 2019 is an important and necessary reform because it updates the Fish and Game Code to impose stricter controls pre-manufacturing, by limiting the distribution of trapping licenses and eliminating fur dealer and fur agent licenses entirely.

The proposed amendments to the Fish and Game Code are consistent with the City of Berkeley's local effort to ban fur products, and represent an important step towards ensuring the conservation of native species.

Thank you for introducing this important piece of legislation, and striving to protect California wildlife.

Respectfully,  
Berkeley City Council

CC: Senator Nancy Skinner  
Assembly Member Buffy Wicks

April 23, 2019

The Honorable Laura Friedman  
Member of the Assembly  
State Capitol, Room 2137  
Sacramento, CA 95814

Re: AB 44 (Friedman) - Fur Products Prohibition Act  
Support from the Berkeley City Council

Dear Assemblymember Friedman,

The Berkeley City Council would like to convey its full support for AB 44, which seeks to protect native species by limiting the trapping, manufacture, and sale of fur products statewide.

The production process of commercial fur products entails varying and extensive forms of recognized animal cruelty, in addition to causing the decline of native species populations. Fur trade industry values are inconsistent with the standards of humane, sustainable, and dignified treatment of commercially used fur-bearing mammals.

Under current law, the manufacture and sale of fur is already prohibited in major metropolitan areas of the state, reflecting the electorate's withdrawal of support from the practice. The Fur Products Prohibition Act is an important and necessary reform because it will have even wider impact, by updating the Fish and Game Code to prohibit the manufacture or sale of fur products throughout the whole state.

The proposed amendments to the Fish and Game Code are consistent with the City of Berkeley's local effort to ban fur products, and represent an important step towards ensuring the conservation of native species.

Thank you for introducing this important piece of legislation, and striving to protect California wildlife.

Respectfully,  
Berkeley City Council

CC: Senator Nancy Skinner  
Assembly Member Buffy Wicks

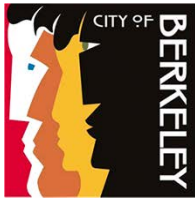

CITY COUNCILMEMBER  
**RIGEL ROBINSON**  
 DISTRICT 7

CONSENT CALENDAR  
 April 23, 2019

To: Honorable Mayor and Members of the City Council

From: Councilmembers Rigel Robinson, Sophie Hahn, Mayor Jesse Arreguin,  
 and Councilmember Lori Droste

Subject: Refer to the City Manager and the Housing Advisory Commission to Consider  
 Reforming the Affordable Housing Mitigation Fee

RECOMMENDATION

Refer to the City Manager, the Planning Commission, and the Housing Advisory Commission to consider possible reforms to the Affordable Housing Mitigation Fee, including adopting a per-square-foot fee structure, potentially on a geographic basis.

POLICY COMMITTEE RECOMMENDATION

On March 21, 2019, the Land Use, Housing & Economic Development Committee adopted the following action: M/S/C (Hahn/Droste) to send the item to the full Council with a Positive Recommendation. Vote: Ayes – Hahn, Droste; Noes – None; Abstain – None; Absent – Arreguin.

BACKGROUND

Currently, all new residential development of five units or more must either pay an Affordable Housing Mitigation Fee to the City's Affordable Housing Trust Fund, set aside 20% of a project's units as below market rate housing, or some combination of the two. For rental developments, the fee is currently calculated based on the number of residential units in the project according to the following formula (BMC Section 22.20.065):

$$[A \times \text{Fee}] - [(B+C)/(A \times 20\%) \times (A \times \text{Fee})]$$

Where:

A = Total number of units in the project

B = Number of Very-Low Income Units provided in the project.

C = Number of Low-Income Units provided in the project.

By calculating Affordable Housing Mitigation Fees on a per-unit basis, current law incentivizes developers to build fewer units. In the past, developers have replaced standard layouts (studio, one-bedroom, and two-bedroom units) with dorm-style layouts (up to eight beds per unit). This increases the *density* of each unit but reduces the overall *number* of units, allowing applicants to pay significantly smaller fees without providing any additional housing.

Another way for developers to reduce their contribution to the Affordable Housing Trust Fund is to build larger, more expensive units, rather than smaller, more affordable units. This perverse incentive is clearly in opposition to the City's affordable housing goals.

This problem was highlighted in a recent report by the Turner Center. In interviews with architects and builders, they were told that a conscious decision was sometimes made to increase unit size but decrease unit count to reduce fees.<sup>1</sup> Calculating the fee on a per-square-foot basis eliminates that incentive. Developers would no longer be able to reduce their contribution to the Affordable Housing Trust Fund by manipulating floor layouts. In addition, by eliminating the financial penalty for building more units, developers would be incentivized to propose denser projects, which is directly in line with the City's housing goals.

Such a change was recently enacted in San Francisco, taking effect January 1<sup>st</sup> of this year. The language from San Francisco's website (<https://sf-planning.org/inclusionary-affordable-housing-program>) describing the process they undertook to arrive at their new model is attached. Staff and the Commissions should consider their research, methodology, and conclusions when drafting their response.

A per-square-foot fee may not be desirable across all neighborhoods in Berkeley. The same Turner Center study found that "in some cities there is a need for larger family-sized units, and in those places a per-square-foot fee that incentivizes smaller units might be less desirable."<sup>2</sup> In considering this referral, staff and the Commissions should consider the need for different housing types in different parts of the City. A per-bed fee may be more appropriate for some neighborhoods where micro-units would be out of place while still disincentivizing dorm-style layouts.

This referral asks staff and the Commissions to analyze the current fee structure and possible alternatives, with particular regard to the per-unit form. Staff and the Commissions should consider the need for different styles of housing in different parts of the city. The final recommendation presented to council should include one or more possible amendments to the code to address these changes.

### FINANCIAL IMPLICATIONS

Potential revenues increases to the Affordable Housing Trust Fund from larger structures facing higher fees; potential revenue decreases from smaller units facing lower fees. Analysis must be conducted to determine the overall effect of these countervailing forces. Multiple fee levels should be assessed, including those that results in net zero changes in Affordable Housing Trust Fund revenues and those that increase revenues.

### ENVIRONMENTAL SUSTAINABILITY

---

<sup>1</sup> [http://turnercenter.berkeley.edu/uploads/Development\\_Fees\\_Report\\_Final\\_2.pdf](http://turnercenter.berkeley.edu/uploads/Development_Fees_Report_Final_2.pdf)

<sup>2</sup> Ibid

Increasing the affordability and density of housing near public transit has the potential to substantially reduce greenhouse gas emissions in line with the City's environmental goals. Potential revenue increases to the Affordable Housing Trust Fund could permit greater expenditures on housing affordability near transit.

CONTACT PERSON

Councilmember Rigel Robinson, (510) 981-7170

Attachments:

1: San Francisco's Amendments (<https://sf-planning.org/inclusionary-affordable-housing-program>)

## Attachment 1: San Francisco's Amendments

2019 Affordable Housing Fee Update

Effective January 1, 2019, residential development projects that comply by paying the Affordable Housing Fee will be subject to the following fee based on the Gross Floor Area of residential use, rather than the number of dwelling units. The fee will be applied to the applicable percentage of the project, as set forth in Section 415.5 of the Planning Code:

**Affordable Housing Fee:** \$199.50 per square foot of Gross Floor Area of residential use, applied to the applicable percentage of the project:

- **Small Projects** (fewer than 25 dwelling units): 20% of the project's Gross Floor Area of residential use
- **Large Projects** (25 or more units), **Rental:** 30% of the project's Gross Floor Area of residential use
- **Large Projects** (25 or more units), **Ownership:** 33% of the project's Gross Floor Area of residential use

**Note:** The impact fee register in place at the time of payment shall be applied. However, a project for which a Site Permit has been issued prior to January 1, 2019 shall remain subject to the fee method and amount set forth in the impact fee register in place as of December 31, 2018. Additionally, projects with an Environmental Evaluation Application that was accepted prior to January 1, 2013 pursuant to Planning Code Section 415.3(b) shall also remain subject to the fee method and amount set forth in the impact fee register in place as of December 31, 2018. [The impact fee register may be found here.](#)

This change is pursuant to amendments to Section 415.5 that were adopted by the Board of Supervisors in July, 2017 (Board File No. 161351). Specifically, the Code requires that the Fee reflect MOHCD's actual cost to subsidize the construction of affordable housing units over the past three years, and directed the Controller to develop a new methodology for calculating, indexing, and applying the Fee, in consultation with the Inclusionary Housing Technical Advisory Committee (TAC). In May, 2018 the Controller and TAC determined that the Fee should be applied on a per gross square foot basis to ensure that MOHCD's cost to construct the required amount of off-site affordable housing is appropriately and equitably captured from all projects, regardless of the size and number of units distributed within the project. The Controller directed MOHCD, in consultation with the Planning Department, to convert MOHCD's per unit cost to a per-square-foot fee, based on the average residential Gross Floor Area of projects that have paid the Fee in the past three years. The Fee amount indicated above has been calculated accordingly.

Pursuant to Section 415.5 and the specific direction of the Controller and TAC, MOHCD shall update the amount of the Affordable Housing Fee each year on January 1, using the MOHCD average cost to construct an affordable unit in projects that were financed in the previous three years and the Planning Department's average residential Gross Floor Area of projects that have elected to pay the Fee and have been entitled in the same time period. Each year this analysis will be updated to include new projects from the most recent year, and drop older projects that no longer fall into the three year period of analysis. The updated Fee amount will be included in the Citywide Impact Fee Register that is posted December 1 and effective on January 1.





Lori Droste  
Berkeley City Council District 8

Consent Calendar

April 23, 2019

To: Honorable Mayor and Members of the City Council

From: Councilmembers Lori Droste, Cheryl Davila, and Rigel Robinson

Subject: Relinquishment of Council Office Budget Funds: “Post-Memory: A Decade of Art and Activism in Berkeley,” an art exhibit in honor of Zachary Cruz

RECOMMENDATION

Adopt a Resolution approving the expenditure of an amount not to exceed \$250 per sponsoring Councilmember, with funds relinquished from the discretionary Council Office Budgets of Councilmember Droste and any other Councilmembers who would like to contribute. Funds would go to cover the costs of the art exhibit “Post-Memory: A Decade of Art and Activism in Berkeley” at UC Berkeley.

2019 marks the ten year anniversary of the death of Zachary Cruz who died from road violence on Berkeley streets. The art exhibit will honor Zachary and raise awareness about road safety and Vision Zero in Berkeley. Additional details about the exhibit are attached.

Donations will go to A to Z Families for Safe Streets, c/o Los Angeles Walks, 830 Traction Ave 3rd Floor, Los Angeles, CA 90013.

FINANCIAL IMPLICATIONS

No General Fund impact. Funds are available from the Councilmembers’ office budget discretionary accounts.

ENVIRONMENTAL SUSTAINABILITY

No adverse effects to the environment.

CONTACT PERSON

Councilmember Lori Droste      510-981-7180

Attachments:

- 1: Resolution
2. Letter from Frank Cruz

RESOLUTION NO. ##,###-N.S.

DONATIONS IN SUPPORT OF "POST MEMORY: A DECADE OF ART AND ACTIVISM  
IN BERKELEY"

WHEREAS 2019 marks the ten year anniversary of the death of Zachary Cruz; and

WHEREAS, Councilmember Droste has surplus funds in her office expenditure account (budget code 010-0282- 410); and

WHEREAS, the art exhibit will raise awareness regarding pedestrian safety and Vision Zero in Berkeley.

NOW THEREFORE, BE IT RESOLVED by the Council of the City of Berkeley that funds relinquished by the Councilmembers from their Council Office Budget up to \$250 per office shall be granted to the A to Z Families for Safe Streets and the production of "Post-Memory: A Decade of Art and Activism in Berkeley."

DRIVE LIKE YOUR KID DIED HERE

**OursDid.org**
EMAIL: [INFO@ZMCFFOUNDATION.ORG](mailto:INFO@ZMCFFOUNDATION.ORG)

FACEBOOK.COM/OURSDID

TWITTER &amp; INSTAGRAM @OURSDID

To: The Berkeley City Council

From: Frank Eugene Cruz, OursDid.org

Re: Request for financial support for “Post-Memory: A Decade of Art and Activism in Berkeley”; a pedestrian safety art show opening April 13, 2019 at the Doe Library, UC Berkeley

Dear Council Members,

As you may recall, [OursDid.org](http://OursDid.org) advocated for formal support from the council for Vision Zero last year through our “Drive Like Your Kid Died Here” campaign at Zachary’s Corner and at City Hall. Since then, I’ve worked with Council Member Lori Droste (District 8) on the process of turning the your political commitment to Vision Zero into policy and best practices. In January, I met with CM Droste, the City Manager, administrators, and other road safety activists to begin this important process, which will help save lives in our East Bay community. Thank you for your commitment, individually and as elected officials, to making Berkeley roads safe and accessible for everyone and for your commitment to make real change on this life or death issue.

Two-thousand-nineteen is the 10-year anniversary of my son, Zachary Michael Cruz’ death to road violence in Berkeley. In light of this somber milestone, OursDid.org is recommitting to our goal of raising awareness for road violence victims and their families. In addition, we are specifically focusing on educating and directly engaging the Berkeley community on the launch of Vision Zero and asking for their buy-in. If there’s one thing I learned at last November’s Vision Zero Cities national conference in New York, it’s that community buy-in is paramount to a successful transition to Vision Zero in communities where road violence against pedestrians and cyclists has become the norm. To advance this goal, OursDid.org is partnering with the Office of the Chancellor at Cal to put on an art show on campus tentatively titled “Post Memory: A Decade of Art and Activism in Berkeley.” The explicit purpose of this exhibit is to both tell Zachary’s Berkeley story, but more importantly to raise awareness for road safety and #VisionZeroBerkeleyNOW.

I see this art show as more than a celebration of Zachary’s life. I see it as an important educational and public awareness project for Vision Zero in Berkeley. Currently, the University is offering space for the exhibit (the Doe Memorial Library) and reception (the Morrison Reading Room at Doe) but hasn’t budgeted funds for the project. As such, I’m asking **all stakeholders** (campus, city government, pedestrian safety advocacy groups, and the business community) to contribute financially to help bring the important message (#VisionZeroBerkeleyNOW) to the community. Can you help us by making a financial contribution? I believe “Post-Memory” will help advance our common goal of creating safe, walkable communities by raising awareness for pedestrian safety and supporting the city’s explicit goal of implementing Vision Zero this year.

So that you might clearly understand our vision for “Post Memory,” as well as our request for financial support, I’m including the following materials:

- A narrative description of the “Post Memory” exhibit
- A working list of the items to be included in the art show which includes;
- Projected costs for production (printing, framing, etc.) of each item
- A selection of artwork from the exhibit

Please let me know if you can make a financial contribution in support of this important project. It would be an honor to include your names, districts, and/or the city logo on our marketing materials which will be distributed by the UC Berkeley Office of Public Relations and on the exhibit brochure for the show. If so, please make your tax-deductible contribution payable to **A to Z Families for Safe Streets**. Thank you for your consideration and your outstanding work on pedestrian and cyclist safety in our community! Please don’t hesitate to call or text if I can answer any questions about this project: (805) 216-7352.

Yours in solidarity,

Frank Eugene Cruz

Zachary’s Dad &

Founder & Creative Director  
“Drive Like Your Kid Died Here”  
<http://oursdid.org>  
<http://facebook.com/oursdid>  
<http://twitter.com/oursdid> &

Founder & Director  
The Zachary Michael Cruz Foundation  
A Pedestrian Safety & Educational Philanthropy Nonprofit Organization  
<http://zmcfoundation.org>  
<http://facebook.com/zmcfoundation>  
<http://twitter.com/zmcfoundation>

## Post-Memory: A Decade of Art and Activism in Berkeley

A Pedestrian Safety Art Show, Opening April 13, 2019 at the Doe Library, UC Berkeley

### Exhibit Description

In 1992, feminist critic Marianne Hirsch developed a new theoretical concept she called “post-memory.” Hirsch describes post-memory as...

the relationship that later generations or distant contemporary witnesses bear to the personal, collective, and cultural trauma of others—to experiences they “remember” or know only by means of stories, images, and behaviors.

This theoretical concept is legible in the aesthetic and activist response to the sudden and public death of a 5-year old child named Zachary Michael Cruz in a Berkeley crosswalk on 27 February 2009.

*Post-Memory: A Decade of Art and Activism in Berkeley* tells the story of this young child’s brief life through snapshots and Zachary’s own kid artwork. In a very real way, these photos and works of art constitute the base of post-memory for Zachary’s family and friends.

The exhibit also highlights subsequent responses to the events of February twenty-seventh by those closest to Zachary, as well as by members of the community at large. These “stories and images” register the personal and collective trauma that Zachary’s sudden and violent death on a public street near the University produced in his family and beyond.

These works, many by artists who have no living memory of Zachary, were produced by artists between the ages of 3 and 55 years old after the Berkeley boy’s death. The art from this period of post-memory (2009-2019) takes the form of origami, mixed-media, illustration, photography, poetry, and music. These creative responses mark one example of a community spontaneously producing post-memory of a trauma some would only ever “remember” or know” secondhand through images and stories.

The conclusion of the exhibit focuses on the artifacts of activism—“behaviors” in Hirsch’s syntax—which remain Zachary Michael Cruz’ true legacy in Berkeley. This section includes community activism, official city documents, and political victories, as well as a new call for change: #VisionZeroNOW in Berkeley.

#### 1. Exhibit Description

- a. Request: Wall print applique <https://imagertransfers.com/pricing.php>
- b. Size: 11” x 14”
- c. Estimated cost: \$195

### Description of Exhibit Items

#### Zachary Michael Cruz

2. “Untitled (Father’s Day Present for Dad)” by Zachary Michael Cruz (oil on canvas, 2005)
  - a. Size: 13 <sup>13/16</sup>” x 16 <sup>3/4</sup>”

- b. Request: NA
- c. Estimated cost: NA
- 3. **“Yellow Submarine”** by Zachary Michael Cruz (reproduction of pastel on paper, 2008)
  - a. Size: 12” x 12”
  - b. Request: Framing and printing
  - c. Estimated cost: \$100
- 4. **“Friend in Me”** by Zachary Michael Cruz and Jodie Cruz (gocco screenprint on paper, 2008-2010)
  - a. Size: 16” x 22”
  - b. Request: Framing
  - c. Estimated cost: \$100
- 5. **“Stick Family”** by Zachary Michael Cruz (marker on paper, 2008)
  - a. Size: 16 <sup>3</sup>/<sub>4</sub>” x 20 <sup>5</sup>/<sub>8</sub>”
  - b. Request: NA
  - c. Estimated cost: NA
- 6. **“Medium Format Cluster”** (3 pieces) by Zachary Cruz and Jeremy Wallace; Chris Dixon (photography, 2008)
  - a. Size: 5.85” x 17.55”
  - b. Request: Framing and printing
  - c. Estimated cost: \$100
- 7. **“Space Ship”** (2 pieces) by Zachary Cruz and Frank Eugene Cruz (wood, nails, and paint, 2006)
  - a. Size: NA (three dimensional); snapshot photo, 4” x 6”
  - b. Request: Stand/shelf for object; framing and printing
  - c. Estimated cost: \$20

### Family & Community

- 8. **“Le Conte Cluster”** (2 pieces, 1 frame) by Ophelia and the 5<sup>th</sup> Grade Class of Le Conte Elementary (photographic reproduction of mixed media/diorama/oragami, 2009)
  - a. “Ophelia’s Memory Box”
    - i. Size: 8” x 6”
    - ii. Note: A dozen origami cranes in blue and gold dangle down from the ceiling above this section
  - b. “A Thousand Cranes”
    - i. Size: 8” x 6”
  - c. Request: Framing and printing
  - d. Estimated cost: \$100
- 9. **“For Your Mother”** by Frank Eugene Cruz (poem, 2009)
  - a. Request: Wall print applique <https://imagertransfers.com/pricing.php>
  - b. Size: 11” x 14”
  - c. Estimated cost: \$195
- 10. **“Baseball is a Game about Living with Loss Cluster”** by Chris Dixon (photography, 2011) (2 pieces, 1 frame)
  - a. “Baseball is a Game about Living with Loss (No. 1)”
    - i. Size: 12” x 18”
  - b. “Baseball is a Game about Living with Loss (No. 2)”
    - i. Size 12” x 18”

- c. Request: Framing
- d. Estimated cost: \$100
- 11. **“Bottle’s Almost Empty”** by Ralph Stollenwerk (screen print ink on paper, 2014)
  - a. Size: 19” x 25”
  - b. Request: NA
  - c. Estimated cost: \$0
- 12. **“Ofrenda LP”** by Frank Cruz & the New Deal, Brian Espinosa (music on vinyl/album artwork, 2014)
  - a. Size: 12” x 18”
  - b. Request: Framing
  - c. Estimated cost: \$100
- 13. **“Zachary’s Headphones”** by Santiago Portilla (photograph, 2010)
  - a. Size: 12” x 18”
  - b. Request: Framing and printing
  - c. Estimated cost: \$100
- 14. **“Berkeley Double Exposure”** by Brian Espinosa, Jodie Cruz, and Chris Dixon (digital art/photography, 2006-2014)
  - a. Size: 12” x 20”
  - b. Request: Framing and printing
  - c. Estimated cost: \$100
- 15. **“Untitled”** by Miles Cruz (pen on paper, 2012)
  - a. Size: 8.5” x 11”
  - b. Request: Framing
- 16. **“Zachary’s Butterfly”** by Beverly Shelton (watercolor on paper, 2010)
  - a. Size: 9” x 12”
  - b. Request: Framing
  - c. Estimated cost: \$80
- 17. **“Drive Like Your Brother Died Here”** by Miles Cruz (marker on paper, 2018)
  - a. Size: 12” x 18”
  - b. Request: Framing
  - c. Estimated cost: \$80

### The Art of Activism/Vision Zero

- 18. **“Zachary’s Corner”** by Anonymous (corrugated metal, 2010)
  - a. Size: Replica street sign <https://www.tapconet.com/hawkins-traffic>
  - b. Request: Cost of street sign production
  - c. Estimated cost:
- 19. **“Derby & Warring”** by Frank Eugene Cruz (photograph, 2009)
  - a. Size: 5.5” x 5.5”
  - b. Request: Framing and Printing
  - c. Estimated cost: \$50
- 20. **“City of Berkeley Proclamation”** by Mayor Tom Bates and the Berkeley City Council (ink on paper, 2011)
  - a. Size: 8.25” x 11”
  - b. Request: NA
  - c. Estimated Cost: \$0

21. **“The Zachary Cruz Scholars at Cal”** by ZMC Foundation/Centers for Educational Equity, Excellence & Education at UC Berkeley (wall print applique, 2011-2019)
  - a. List of names, majors, and graduation year of the Zachary Cruz Memorial Scholarship recipients from 2011-present
    - o *Ethan Hill, BA (Rhetoric/Political Science), Class of 2020*
    - o *Robert L. Reyes III (English), Class of 2020*
  - b. Size: 11” x 14”
  - c. Request: Wall print applique <https://imagertransfers.com/pricing.php>
  - d. Estimated cost: \$195
22. **“Zachary Michael Cruz Foundation Cluster”** (3 items, 1 frame) by Brian Espinosa, Jodie Cruz (graphic design/photography, 2008-2010)
  - a. Size: 12” x 12”
  - b. Request: Framing and printing
  - c. Estimated cost: \$100
23. **“ZMCF Benefit Concert Poster”** by Brian Espinosa (graphic design, 2011)
  - a. Size: 11” x 17”
  - b. Request: Framing
  - c. Estimated cost: \$80
24. **“Drive Like Your Brother Died Here, Derby & Warring”** by Chris Dixon (photography, 2018)
  - a. Size: 12” x 18”
  - b. Request: Framing and printing
  - c. Estimated cost: \$100
25. **“Streets Have Stories Cluster”** (3 pieces, 1 frame) by Lauren Holland, Anonymous (journalism/newsprint/photography, 2018)
  - a. Size: 12” x 21” (x 2) (journalism/newsprint pieces)
  - b. Size: 12” x 18 (photograph)
  - c. Request: Framing and printing of photograph
  - d. Estimated Cost: \$100

### Signs of Protest

Note: Imagine these picket signs, attached to wooden stakes, rising up from the top of the ledge. The pieces of activist art hang below. The signs are high up, as if hoisted in the air in homage to Berkeley’s campus activist tradition.

26. **“Drive Like Your Cal Bear Died Here Yard Sign”** by OursDid.org and Brian Espinosa (graphic design/screen print on corrugated plastic, 2018)
  - a. Size: 18” x 24”
  - b. Request: NA
  - c. Estimated Cost: \$0
27. **“Ours Did Picket Sign #1”** by OursDid.org (graphic design/ink on paper, 2018)
  - a. Size: 12” x 18”
  - b. Request: NA
  - c. Estimated Cost: \$0
28. **“Ours Did Sign Picket Sign #2”** by OursDid.org (graphic design/ink on paper, 2018)
  - a. Request: NA
  - b. Estimated Cost: \$0



29. **“Crash Not Accident Picket Sign”** by Transportation Alternatives and Families for Safe Streets NYC (graphic design/ink on paper, 2018)
  - a. Size: 12” x 18”
  - b. Request: NA
  - c. Estimated Cost: \$0
30. **“#VisionZeroNOW Picket Sign”** by OursDid.org (graphic design/ink on paper, 2019)
  - a. Request: NA
  - b. Estimated Cost: \$0

“Post-Memory”: Selected Exhibit Items



“Untitled (Father’s Day Present for Dad)” by Zachary Michael Cruz (oil on canvas, 2005)



**“Yellow Submarine”** by Zachary Michael Cruz (pastel on paper, 2008)



“A Thousand Cranes” by the 5<sup>th</sup> Grade Class of Le Conte Elementary (paper/origami, 2009)



“Bottle’s Almost Empty” by Ralph Stollenwerk (screen print ink on paper, 2014)



“Derby & Warring” by Frank Eugene Cruz (digital photography, 2010)



**"Streets Have Stories"** by Janice Lau (digital photography, 2018)



**“Mine Did”** by Christopher Dixon (digital photography, 2018)





Office of the City Manager

PUBLIC HEARING

April 23, 2019

*(Continued from March 26, 2019)*

To: Honorable Mayor and Members of the City Council  
 From: Dee Williams-Ridley, City Manager  
 Submitted by: Timothy Burroughs, Director, Planning & Development Department  
 Subject: ZAB Appeal: 1722 Walnut Street

RECOMMENDATION

Conduct a public hearing, and upon conclusion adopt a Resolution to affirm the Zoning Adjustments Board decision to deny Use Permit/Variance #ZP2018-0021 to legalize an unpermitted detached dwelling unit in the rear yard area of a lot legally developed with an eight-unit apartment building, and dismiss the appeal.

FISCAL IMPACTS OF RECOMMENDATION

None.

CURRENT SITUATION AND ITS EFFECTS

On November 8, 2018, the Zoning Adjustments Board (ZAB) held a public hearing and denied Use Permit/Variance #ZP2018-0021 by a vote of 6-1-0-1 (Yes: Kahn, Sheahan, Selawasky, O’Keefe, Olson, Wright, Pinkston; No: Clarke; Abstain: None; Absent: Kim). On November 15, 2018, staff issued the notice of the ZAB decision. On November 28, 2018, Margrett Lewis and Joe Priest (“Appellants”) filed an appeal with the City Clerk. The Clerk set the matter for review by the Council on March 26, 2019.

BACKGROUND

The project site is a 5,479-square-foot parcel that is developed with an approximately 6,000-square-foot, two-story, eight-unit apartment building that was constructed in 1926. No off-street parking exists on the site. Approximately six years ago, the property owners built a detached cottage (i.e. dwelling unit) without permits in the southwestern (rear left) corner of the property in a location where a shed had been located.

In February 2017, John Stevick (“Applicant”) submitted a request for a zoning determination on the most expedient way to legalize the subject dwelling unit. The Zoning Research Letter response, dated April 3, 2017 (see Attachment 4) is that the project would be subject to current development standards of the Berkeley Municipal Code and that Variances would be required to approve the project, and that Variance findings are “often difficult to make.”

A Variance is a deviation from current zoning requirements that permits a landowner to not comply with the standards required of other landowners in the same zone. Typically, a variance is granted when the property owner can demonstrate that existing zoning regulations present a practical difficulty in making use of the property due to physical characteristics of the property. The classic example involves a residential lot that is identical in size and shape to the surrounding lots, but suffers from the presence of a large, immovable boulder. In this instance, a variance waiving ordinary setback requirements may permit the landowner to build a house, even though the boulder makes construction of the house within the normal zoning envelope impossible.<sup>1</sup>

On November 14, 2017, the Neighborhood Services-Enforcement Division sent a Notice of Violation (NOV) to the property owners for construction of a dwelling unit without the required Land Use or Building and Safety Division permits or approvals. The property owners submitted the subject application on January 28, 2018. In addition to the Use Permit to construct a new dwelling unit and two Administrative Use Permits (AUPs) to reduce the required rear yard setback and to reduce the building-to-building separation, the project requires four Variances from the Multi-Family Residential (R-4) zoning development standards:

- Variance to decrease the required left side yard setback below the 4-foot minimum to 2.2 feet;
- Variance to further increase the non-conforming 60% lot coverage to 61% where a maximum of 45% is permissible for a lot with a two story building;
- Variance to not provide and to further decrease the non-conforming Useable Open Space per dwelling, providing 990 square feet, where a minimum of 1,800 square feet is required; and
- Variance to not provide the required off-street parking space for a new dwelling unit.

In order to approve a Variance, all of the following Findings must be made (BMC 23B.44.030):

1. There are exceptional or extraordinary circumstances or conditions applying to the land, building or use referred to in the application, which circumstances or conditions do not apply generally to land, buildings and/or uses in the same District;
2. The granting of the application is necessary for the preservation and enjoyment of substantial property rights of the subject property's owner;
3. The establishment, maintenance or operation of the use or the construction of a building, structure or addition thereof, to be approved will not, under the

---

<sup>1</sup> Fulton, William and Shigley, Paul. *Guide to California Planning, 4<sup>th</sup> Edition*. Point Arena: Solano Press Books, 2012.

circumstances of the particular case, materially affect adversely the health or safety of persons residing or working in the neighborhood of the property of the applicant and will not, under the circumstances of the particular case, be materially detrimental to the public welfare or injurious to property or improvements in said neighborhood; and that the granting of the Variance will promote the municipal health, welfare and safety and benefit the City as a whole;

4. Any other variance findings required by the Section of the Ordinance applicable to that particular Variance.

After multiple rounds of review to collect all the pertinent background information and obtain a complete and accurate application, staff prepared a staff report to the ZAB that recommended denial of the permit application because the required Variance findings cannot be made and because the project is inconsistent with the Purposes of the District. At the November 8, 2018 meeting, the ZAB held a public hearing, discussed the project, concluded it could not make the Findings to approve the Variances, and denied the project.

#### ENVIRONMENTAL SUSTAINABILITY

There are no environmental factors associated with this project.

#### RATIONALE FOR RECOMMENDATION

The issues raised in the Appellant's letter, and staff's responses, are as follows. For the sake of brevity, the appeal issues are not re-stated in their entirety; refer to the attached appeal letter for full text.

Issue 1: "...both the Planning Department and ZAB's recommendations and rulings directly contradict their mission to maintain and grow the housing supply, particularly rent controlled units." "ZAB's demand that this cottage be demolished is: (iii) a direct contradiction of Berkeley's stated goals of providing housing." [pages 1 and 2 of attached appeal letter]

Response 1: Policy H-19 of the Housing Element is to encourage housing production adequate to meet the housing production goals established by ABAG's Regional Housing Needs Determination for Berkeley. There are, however, eleven stated purposes of the Zoning Ordinance (Ordinance), found in Chapter 23 of the Berkeley Municipal Code (BMC), which include:

- Implementation of *all* policies of the City's adopted General and Area Plans [emphasis added];

- Regulation of the location and use of land, buildings and structures to encourage the more appropriate use of land and a compatible and harmonious relationship among land uses; and
- Provision of adequate usable open space, off-street parking and off-street loading spaces for specified land uses by requiring certain reservations of land and structures for such purposes, and by regulating the number, placement and location of such spaces and areas (BMC Section 23A.04.030).

The Ordinance states, “No land or building shall be used, or designed to be used, nor shall any new building or structure be constructed [...] except as permitted by this Ordinance, either as of right or by permit.” There are four development standards—side yard setback, lot coverage, Useable Open Space, parking—with which the illegal construction fails to comply and, therefore, is not permitted by the Ordinance. Staff’s recommendation and ZAB’s decision properly accounted for all required State and local laws and policies.

Issue 2: “ZAB Staff appeared to have gone out of their way to treat the application by John Stevick differently than others in several ways.” [page 2]

Response 2: The Appellants provide no evidence how staff or ZAB treated the Applicant differently than other applicants and is unclear what pictures the Appellants are referring to that staff failed to distribute. Staff provided all correspondence received during the processing of the application to the ZAB up until the noon deadline the day of the meeting, after which correspondents must bring their own correspondence to ZAB. The Applicant presented additional information to ZAB at the hearing, including written arguments and photographs, which were considered by the decision-makers.

Issue 3: “ZAB’s demand that this cottage be demolished is: (i) a clear physical and monetary stand which contradicts the US Constitution.” [page 2]

Response 3: The Appellants do not have a constitutional right to maintain an unpermitted, illegally constructed, nonconforming structure on their property. ZAB’s decision to require removal of the Appellant’s illegally constructed building is well within its authority to enforce the Zoning Ordinance.

Issue 4: ZAB’s demand that this cottage be demolished is...(ii) an example of the ZAB treating the owners [...] differently than other large developers. [page 2, 5]

- Response 4: The Appellants may be referencing a 2016 ZAB approval of Use Permit #ZP2016-0132 for construction of a duplex behind a four-unit apartment building. Unlike the subject project, that 2016 Use Permit complied with all development standards of the Zoning Ordinance, as allowed by right or permissible with AUP approval. No Variances were required, requested, or granted. ZAB evaluated both projects for consistency with the Zoning Ordinance and voted accordingly.
- Issue 5: “If 1722 Walnut Street were to be a completely empty lot today, the subject property could be approved for the development of 19 or more units...” [page 5]
- Response 5: As the underlying R-4 Zoning District does not have a maximum density standard, the Appellant’s assertion may be correct if the proposed project complied with the development standards of the District. However, lot coverage, setbacks, open space and parking requirements would each limit such a hypothetical project to the same degree it limits the subject proposal.
- Issue 6: “ZAB’s demand that this cottage be demolished is: (iv) a lost opportunity to work with an owner to develop smart infill that is aesthetically pleasing, has no impact on neighboring properties, is walkable to public transportation, and, most importantly, helps mitigate the unprecedented housing crisis Berkeley states we are in on their own website.” [page 2]
- Response 6: It is the responsibility of ZAB to administer the provisions of the Zoning Ordinance (BMC 23B.04.010.A). ZAB followed the framework of regulations regarding the construction of buildings and additions and the size and coverage of lots (BMC 23A.04.030.C).
- Issue 7: There clearly are exceptional or extraordinary circumstances or conditions, in terms of homelessness. [page 3]
- Response 7: In order to approve a Variance, the City must be able to make the finding that, “There are exceptional or extraordinary circumstances or conditions applying to the land, building or use referred to in the application, which circumstances or conditions do not apply generally to land, buildings and/or uses in the same District.” The use of a Variance is generally understood as a means of reestablishing parity for property owners when their property is unusually situated or otherwise constrained from achieving the same type of development that would otherwise be allowed in the area. The subject property is a flat rectangular lot with

substantial existing legal development (an 8-unit apartment building), so it does not qualify for a Variance.

Issue 8: “[ZAB] ruled against keeping the rent-controlled unit in place, a direct contradiction to one of their most important and loudly stated missions.” [page 4]

Response 8: As previously stated in Responses 1 and 6 above, it is the responsibility of ZAB to fairly and consistently administer the provisions of the Zoning Ordinance first and foremost and, within that framework, to further the goals and policies of the City’s General Plan and other plans. As such, denial of the illegal dwelling unit is not contradictory, but is instead an appropriate action and consistent with ZAB’s authority.

The illegal dwelling, which is located on a parcel with a rent-controlled apartment building, is currently registered with the Rent Stabilization Board (RSB). Since the dwelling never received land use or building permits and, therefore, never received a Certificate of Occupancy, it is not exempt from rent control, but neither is it legally habitable and should not be registered as available for rent. If the Variance and Use Permits were granted, then, the dwelling would be required to receive all required building permits and would be issued a Certificate of Occupancy, thereby exempting it from rent control.

Staff also notes that rent control does not equate to affordable housing. As mentioned in the November 8, 2018 ZAB staff report, as early as 2016, the cottage was listed on Airbnb along with at least five other of the apartments in the main building. Based on the current availability of the unit(s), as well as the frequency of the reviews, the registered rent ceiling resets to market rate approximately two to four times a year. Currently, the subject 346-square-foot dwelling rents for \$3,580 per month, inclusive of utilities and an 18% monthly price discount.<sup>2</sup>

Issue 9: Staff’s restricted interpretation of property rights, “flies in the face of the U.S. Constitution. It is clearly a physical and monetary taking of the owner’s property.” [page 4]

Response 9: The second finding the City must make in order to grant a Variance is that, “The granting of the application is necessary for the preservation and enjoyment of substantial property rights of the subject property’s owner.” Property rights are a property owner’s ability to use his or her property in a manner consistent with the applicable provisions of the

---

<sup>2</sup>[https://www.airbnb.com/rooms/14265796?location=Berkeley%2C%20CA%2C%20United%20States&adults=1&guests=1&s=CW1lIdq3&check\\_in=2019-04-01&check\\_out=2019-04-30](https://www.airbnb.com/rooms/14265796?location=Berkeley%2C%20CA%2C%20United%20States&adults=1&guests=1&s=CW1lIdq3&check_in=2019-04-01&check_out=2019-04-30)

Zoning Ordinance; the application cannot be used to support any condition that a property is in, or made to be, that is unlawful. Property rights are not directly related to the financial viability or profitability of a property. Contrary to the Appellants' statement, requiring property owners to remove an illegally constructed, unpermitted structure that does not comply with the Zoning Ordinance is well within ZAB's authority.

Issue 10: Staff illogically concludes that the project does not meet the purpose of the District to "Make available housing for persons who desire convenience of location and a reasonable amount of Useable Open Space. [pages 4-5]

Response 10: First to clarify, it is not staff's decision that is being appealed, but the ZAB's decision.

The Appellants state that the footprint of the illegal dwelling is not much larger than a previous detached structure that existed on the site and that the garden is actually larger than it was previously.

As shown on the 1950 Sanborn Map, a garage was located on the subject site in much the same location, but smaller footprint, as the existing illegal dwelling. A site plan included in a plan set for a 1990 Building Permit that was provided by the Applicant, however, shows the garage had been replaced by a much smaller, approximately 148-square-foot trash and bike shed. See Figure 1 below. The legal condition of the property is, therefore, reflected in the 1990 site plan.

**Figure 1: 1722 Walnut Street Rear Yard Plan**

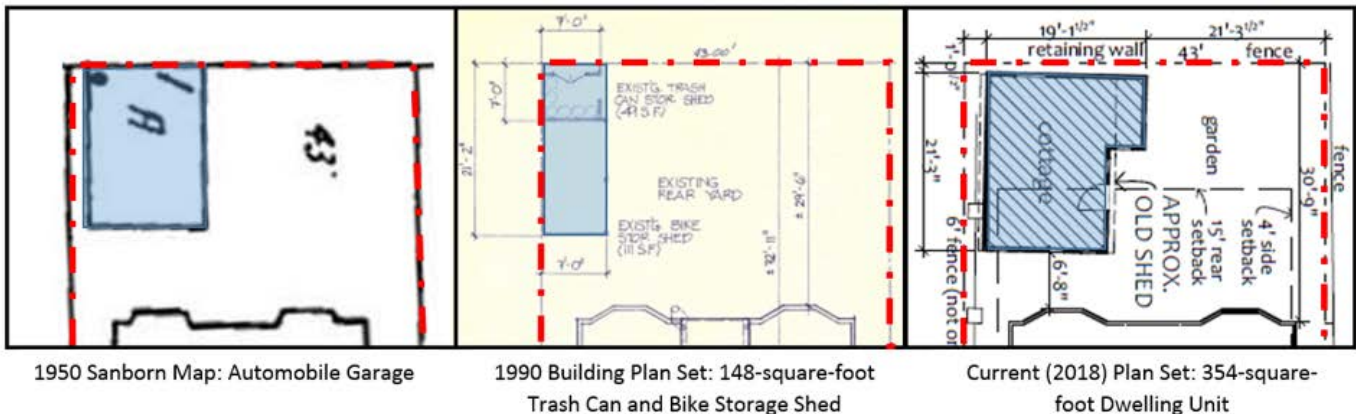

Useable Open Space is defined as the area of a lot reserved for active or passive recreation use that is accessible to the occupants of the building and meets certain dimensional requirements for size, slope, and

landscape / hardscape area (BMC 23D.04.050). The existence of a foundation slab, as mentioned by the Appellants, does not exempt an area as Useable Open Space; the construction of a dwelling does.

The project site is already non-conforming for Useable Open Space under legal conditions. Approximately 1,416 square feet exist (pre-project) where 1,600 square feet are required for the eight legal dwelling units. Adding another dwelling and removing pre-existing useable open space would result in a deficit of approximately 810 square feet. This would fail to accomplish one of the stated objectives of the R-4 zoning district.

#### ALTERNATIVE ACTIONS CONSIDERED

Pursuant to BMC Section 23B.32.060.D, the Council may (1) continue the public hearing, (2) reverse, affirm, or modify the ZAB's decision, or (3) remand the matter to the ZAB.

#### ACTION DEADLINE:

Pursuant to BMC Section 23B.32.060.G, if the disposition of the appeal has not been determined within 30 days from the date the public hearing was closed by the Council (not including Council recess), then the decision of the Board shall be deemed affirmed and the appeal shall be deemed denied.

#### CONTACT PERSONS

Timothy Burroughs, Director, Planning & Development Department, (510) 981-7437  
Leslie Mendez, Senior Planner, Planning & Development Department, (510) 981-7426

#### Attachments:

- 1: Resolution  
    Exhibit A: Findings for Denial
- 2: Appeal Letter, dated November 28, 2018
- 3: ZAB Staff Report with Memorandum, dated November 8, 2018
- 4: Zoning Research Letter, dated April 3, 2017
- 5: Index to Administrative Record
- 6: Administrative Record
- 7: Public Hearing Notice



RESOLUTION NO. ##,###-N.S.

DENYING USE PERMIT/VARIANCE #ZP2018-0021 TO LEGALIZE AN UNPERMITTED DETACHED DWELLING UNIT IN THE REAR YARD AREA OF AN EXISTING 8-UNIT APARTMENT BUILDING AT 1722 WALNUT STREET IN THE MULTI-FAMILY RESIDENTIAL (R-4) ZONING DISTRICT

WHEREAS, on January 29, 2018, John Stevick (“Applicant”) filed an application to legalize a detached dwelling unit located in the rear yard area of an existing eight-story apartment building located at 1722 Walnut Street (“Project”); and

WHEREAS, on September 5, 2018, staff deemed this application complete; and

WHEREAS, on November 8, 2018, at a duly noticed public hearing, the Zoning Adjustments Board denied Use Permit/Variance #ZP2018-0021 for the reasons set forth in a notice of decision released on November 15, 2018; and

WHEREAS, on November 15, 2018, staff issued the notice of the ZAB decision; and

WHEREAS, on November 28, 2018, Margrett Lewis and Joe Priest filed an appeal of the ZAB decision with the City Clerk; and

WHEREAS, on March 26, 2019, the Council held a public hearing to consider the ZAB’s decision, and, in the opinion of this Council, the facts stated in or ascertainable from the public record, including comments made at the public hearing, warrant denying the project.

NOW THEREFORE, BE IT RESOLVED by the Council of the City of Berkeley that the Council hereby adopts the findings for denial made by the ZAB in Exhibit A, affirms the decision of the ZAB to deny Use Permit/Variance #ZP2018-0021, and dismisses the appeal.

Exhibits

A: Findings for Denial

---

## FINDINGS FOR DENIAL

NOVEMBER 8, 2018

# 1722 Walnut Street

**Use Permit/Variance #ZP2018-0021 to permit a ninth dwelling unit on a lot with an existing two-story, eight unit apartment building.**

### PERMITS REQUIRED

---

- Use Permit to construct a new dwelling unit, under BMC Section 23D.40.030
- Administrative Use Permit (AUP) to reduce the rear yard setback for two or more Main Buildings which contain dwelling units under BMC 23D.40.070.D.1
- Administrative Use Permit (AUP) to reduce the required building separation between two or more main building that contain dwelling units under BMC 23D.40.070.D.2
- Variance to decrease the required left side yard setback below minimum requirement per BMC 23D.40.070.D
- Variance to further increase the non-conforming lot coverage over the maximum requirement per BMC 23D.40.070.E
- Variance to not provide and to further decrease the non-conforming Useable Open Space per dwelling below the minimum requirement per BMC 23D.40.070.F
- Variance to not provide the minimum parking requirement (one space) for a new dwelling unit per BMC 23D.40.080.A

### I. VARIANCE FINDINGS

---

Pursuant to Berkeley Municipal Code Section 23B.44.030.B, the City cannot make the findings required by Berkeley Municipal Code Section 23B.44.030.A, and therefore must deny the Variances to: (1) to permit a 2.2-foot side yard setback where a minimum of 4 feet is required for a first story by BMC 23D.40.070.D; (2) to not provide off-street parking space that is required for the new dwelling by BMC 23D.40.080.A; (3) to further increase the existing non-conforming 60% lot coverage to 61% where the maximum is 45% for a property with a two-story building per BMC 23D.40.070.E; and (4) to not provide the required Useable Open Space and further reduce the existing non-conforming open space to 990 square feet, where double that (1,800 square feet) is required by BMC 23D.40.070.F, for the following reasons:

- i. *There are exceptional or extraordinary circumstances or conditions applying to the land, building or use referred to in the application, which circumstances or conditions do not apply generally to land, buildings and/or uses in the same District:*

The applicant has provided no evidence, nor can staff find evidence of circumstance or conditions that apply to the land, building or use which do not generally apply to land buildings and/or uses in the same District. Neither access to public transportation nor existence of an illegal condition are considered unique or otherwise exceptional or extraordinary. Similarly, due to the age of buildings and the various changes made over time to the Zoning Ordinance, many buildings and sites are non-conforming in this District to varying degrees, including the subject site. This finding cannot be made.

- ii. *The granting of the application is necessary for the preservation and enjoyment of substantial property rights of the subject property's owner:*

Staff interprets property rights as a property owner's ability to use his or her property in a manner consistent with the applicable provisions of the Ordinance; the application cannot be used to support any condition that a property is in, or made to be, that is unlawful. Nor is it related to the financial viability or profitability of a property. The applicant has not provided evidence that the use of the property with its unpermitted condition is necessary for the preservation and enjoyment of substantial property rights. In fact, the property owners purchased, and have managed, a property with eight lawful, rental dwelling units for several years. This finding cannot be made.

- iii. *The establishment, maintenance or operation of the use or the construction of a building, structure or addition thereof, to be approved will not, under the circumstances of the particular case, materially affect adversely the health or safety of persons residing or working in the neighborhood of the property of the applicant and will not, under the circumstances of the particular case, be materially detrimental to the public welfare or injurious to property or improvements in said neighborhood; and that the granting of the Variance will promote the municipal health, welfare and safety and benefit the City as a whole:*

One of the purposes of the R-4 District is to "Make available housing for persons who desire both convenience of location and a reasonable amount of Useable Open Space." The project site is currently non-conforming for Useable Open Space and exceeds allowable lot coverage, the proposed project exacerbates both these conditions. The project, therefore, also conflicts with the purposes of the Zoning Ordinance in that it exceed the appropriate intensity of development of land and buildings through excessive lot coverage (BMC 23A.04.030.C) and it does not provide for adequate usable open space or off-street parking (BMC 23A.04.030.E). This Finding cannot be made.

November 28, 2018

CITY OF BERKELEY  
CITY CLERK DEPT808 Gilman Street  
Berkeley, CA 94710Berkeley City Clerk  
2180 Milvia Street, 1st Fl  
Berkeley, CA 94704

2018 NOV 28 PM 4: 52

**Re: Appeal to the City Council of Zoning Adjustment Board Decision  
Use Permit/Variance #ZP2018-0021  
1722 Walnut Street, Berkeley, CA 94709**

Dear City Clerk,

As local business owners, we strongly object to the decision made by the Zoning Adjustment Board (ZAB) in this case; **it is offensive that this beautiful cottage should be demolished.** We work here in Berkeley and would like to rent a place like this to reduce our significant commutes. We and many others have problems with Berkeley's lack of affordable housing. It is our hope that the City Council will recognize the value of keeping this rent-controlled unit in place.

In summary, we feel that both the Planning Department and ZAB's recommendations and rulings directly contradict their mission to maintain and grow the housing supply, particularly of rent controlled units. Their explanations given for their findings do not support their conclusions and further, the ZAB is not treating this property the same as others in the City of Berkeley. Following a brief summary, I will address each ZAB Finding Conclusion in detail and in order.

The City of Berkeley acknowledges that *Berkeley and Alameda County are in the midst of an unprecedented housing crisis.*<sup>1</sup> And yet, ZAB is insisting the one-bedroom cottage shown below be demolished



despite noting in their own findings that *“the dwelling unit is aesthetically pleasing, and that at its current height and massing, has minimal impact to air, views, or light of the existing or neighboring properties, is within 0.5 miles of Downtown BART, 0.1 miles of the closest bus stop, 0.2 miles of the closest trans-bay bus stop, and 0.2 miles of the closed UC Berkeley shuttle.”*<sup>2</sup>

<sup>1</sup> <https://www.cityofberkeley.info/homeless-entry/>.

<sup>2</sup> ZAB Staff Report for Board Action re 1722 Walnut Street, November 8, 2018.

It was also noted by the ZAB that the zoning rules being applied by the Staff to demand demolition were not in place when the building and shed were built in the early 1900's. As evidenced by fire map records and illustrated by Architect, Catherine Roha, the cottage has existed for 6 years within a footprint barely larger than that of the shed it replaced (and smaller than the shed's concrete pad).

We attended the ZAB November 8<sup>th</sup> meeting. ZAB Staff appeared to have gone out of their way to treat the application by John Stevick differently than others in several ways. In addition to the unsupported and contradictory reasoning in the Planning Department's Findings, the Staff failed to distribute the pictures and information provided as it did for the applicants of other projects at the same meeting. The Staff did not allow the applicant to rebut testimony or provide further comment as it did for other applicants at the same meeting.

ZAB's demand that this cottage be demolished is: (i) a clear physical and monetary stand which contradicts the US Constitution, (ii) an example of the ZAB treating the owners, long time Berkeley residents, differently than other large developers, (iii) a direct contradiction of Berkeley's stated goals of providing housing, and (iv) a lost opportunity to work with an owner to develop smart infill that is aesthetically pleasing, has no impact on neighboring properties, is walkable to public transportation, and, most importantly, helps mitigate the *unprecedented housing crisis* Berkeley states we are in on their own website.<sup>3</sup>

Each of the Planning Department's three findings will now be addressed in detail:

- i. There are exceptional or extraordinary circumstances or conditions applying to the land, building or use referred to in the application, which circumstances or conditions do not apply generally to land, buildings and/or uses in the same District.*

The ZAB staff concluded that there are no exceptional or extraordinary circumstances or conditions applying to the land or building. Nothing could be further from the truth. The subject property is unique in that it has a location where an infill unit could and has been added without affecting current residents, impacting adjacent properties, or reducing green space. And it has owners who would be willing to add infill units at their own cost, to provide much needed housing. Further, the ZAB's failure to recognize the added value of the cottage has resulted in a lost opportunity of providing an additional rent-controlled unit to the City of Berkeley. It goes without saying, each and every additional housing unit is desperately needed.

---

<sup>3</sup> <https://www.cityofberkeley.info/homeless-entry/>.

The subject building is shown below and is the only commercial residential building with a garden among the adjacent properties. The garden boxed in red:

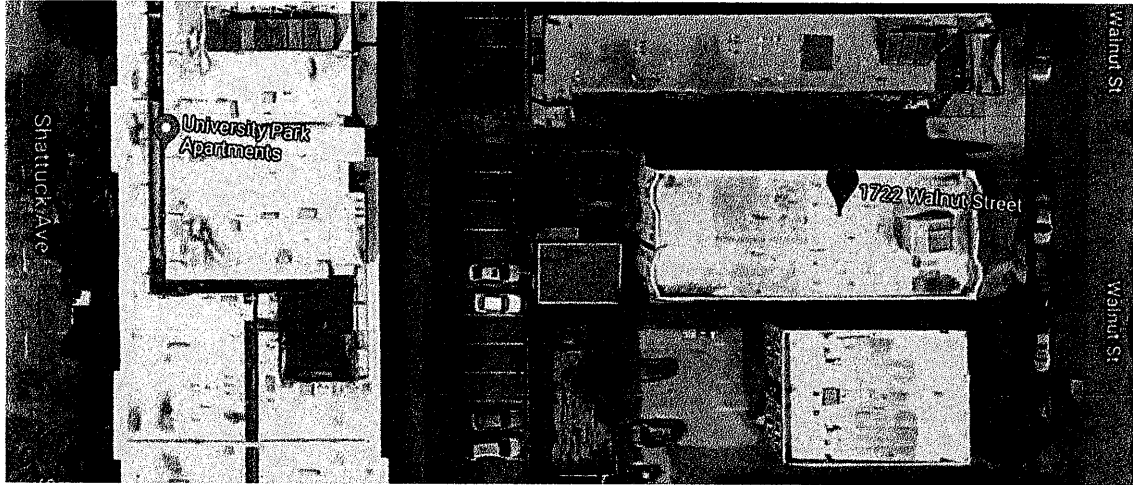

There clearly are exceptional or extraordinary circumstances or conditions, in terms of homelessness. The pictures below were taken in Berkeley on the morning of the ZAB hearing on November 8<sup>th</sup>. Many of these folks could manage to live in an apartment with Section 8 or other assistance.

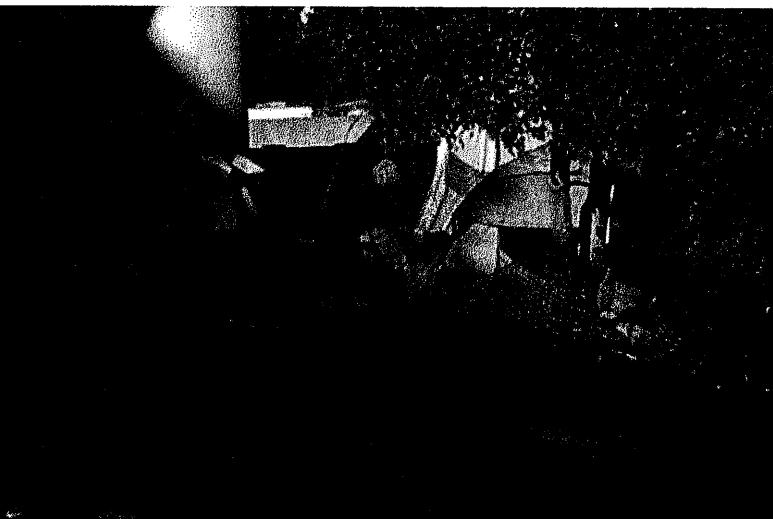
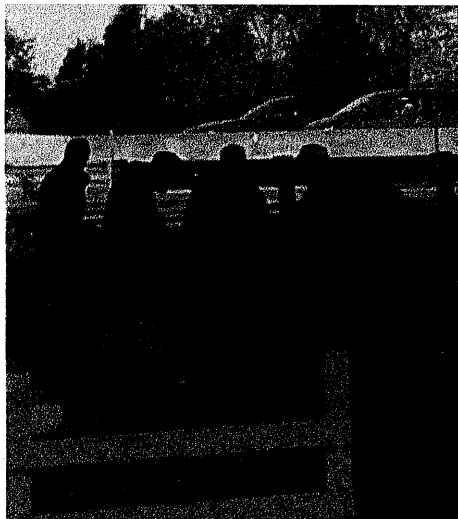

It is also very important to note that several ZAB board members proudly stated that they would not be able, in good conscience, to eliminate or take any existing rent-controlled units off the market during the November 8<sup>th</sup> meeting. However, when addressing our project, they ruled against keeping the rent-controlled unit in place, a direct contradiction to one of their most important and loudly stated missions.

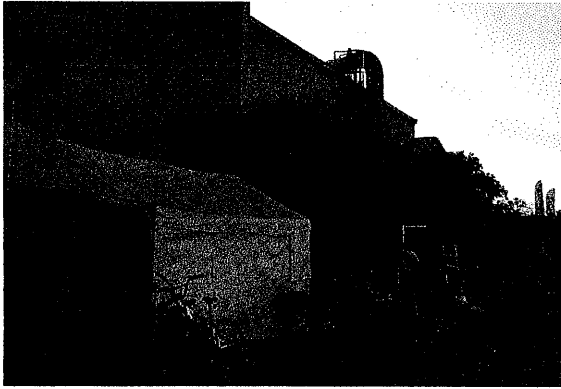

The ZAB Staff's argument that exceptional or extraordinary circumstances or conditions (e.g. *Berkeley and Alameda County being in the midst of an unprecedented housing crisis*) can be ignored simply because they judge the circumstance to be widespread "in the same District" is both hypocritical and nonsensical. The owners would be more than happy to meet with ZAB to show how the unit was constructed and currently serves as a unique, safe, and habitable home.

**ii. *The granting of the application is necessary for the preservation and enjoyment of substantial property rights of the subject property's owner:***

"Staff interprets property rights as a property owner's ability to use his or her property in a manner consistent with the applicable provisions of the Ordinance; the application cannot be used to support any condition that a property is in, or made to be, that is unlawful. Nor is it related to the financial viability or profitability of a property." The Planning Department Staff states they have restricted their interpretation of property rights to be confined to the provisions of "the Ordinance," which flies in the face of the U.S. Constitution. This is clearly a physical and monetary taking of the owner's property. Staff also ignored the owner's other stated use and enjoyment of the subject property, which is providing much needed housing.

**iii. *The establishment, maintenance or operation of the use or the construction of a building, structure or addition thereof to be approved will not, under the circumstances of the particular case, materially affect adversely the health or safety of persons residing or working in the neighborhood of the property of the applicant and will not, under the circumstances of the particular case, be materially detrimental to the public welfare or injurious to property or improvements in said neighborhood; and that the granting of the Variance will promote the municipal health, welfare and safety and benefit the City as a whole.***

In regards to this Finding, Staff initially states: "One of the purposes of the R-4 District is to *"Make available housing for persons who desire both convenience of location and a reasonable amount of Useable Open Space."* Then illogically concludes "this Finding cannot be made," because

of coverage and parking conditions. As was noted by ZAB member Clarke, the coverage has not significantly changed as the cottage essentially takes up the same space as the shed that has been in existence since the building was constructed in the early 1900's (we believe 1917), see the plan view below:

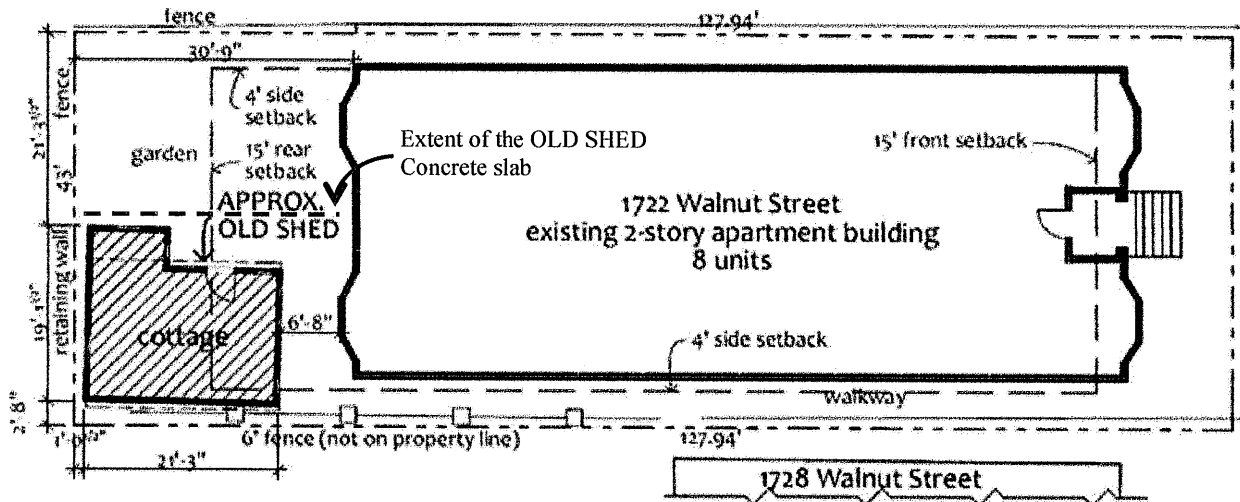

The building was constructed within the applicable rules and laws of the time. The cottage barely extends beyond the footprint of the pre-existing shed and is well within the original concrete pad of the shed. **The garden size is actually larger than it was previously** as the shed included an eight foot wide uncovered concrete slab in front of it that was removed. And as shown above, this garden is the only green area among the adjacent commercial rental properties.

During the previous applicant's (John Stevick) application preparation, he personally canvassed the many multi-residential buildings within 300 feet of the subject property. Every conversation he had was concluded with a signature of support. He did not run into a single criticism of the existing cottage. The one and only request presented to him in order to secure support was a letter from the owners of the 84-unit building immediately west expressing support so long as the owners agree that future costs incurred to maintain the retaining wall between the two properties be split. As no objections to the cottage's existence have been presented, we ask that the cottage be legalized as its presence does not impact anyone.

In regards to treating property owners equally, Berkeley has approved the building of two two-story units on the concrete parking lot of 1728 Walnut Street. In regards to parking, the ZAB staff has noted *"the dwelling unit [cottage] is aesthetically pleasing, and that at its current height and massing, has minimal impact to air, views, or light of the existing or neighboring properties, is within 0.5 miles of Downtown BART, 0.1 miles of the closest bus stop, 0.2 miles of the closest trans-bay bus stop, and 0.2 miles of the closed UC Berkeley shuttle."*<sup>4</sup> Few of the tenants in this area actually own cars or need a parking spot. One of Berkeley's stated goals is to reduce driving, congestion and greenhouse gases produced by automobiles.

We are also of the understanding that if 1722 Walnut Street were to be a completely empty lot today, the subject property could be approved for the development of 19 or more units, many more than what currently exists on the property. This appears to me as one of the most important realities to note. If the lot itself would support additional housing units under current state and local codes, legalization of the cottage should be granted.

<sup>4</sup> ZAB Staff Report for Board Action re 1722 Walnut Street, November 8, 2018.



In summary, this aesthetically pleasing cottage has no negative impacts on neighboring properties, is situated very close to public transportation eliminating the need for parking, and would continue providing a home to Berkeley residents. I fully hope the Council reconsiders the ZAB's demand for demolition.

Sincerely,

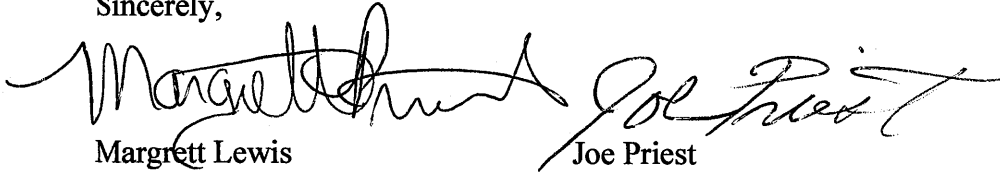

Margrett Lewis

Joe Priest

### **A list of facts and statements for consideration:**

- The ZAB written explanations are not, in our opinion, accurate. The Planning Department's Findings should have concluded this unit could be allowed.
- The ZAB board's verbal comments: "this cottage has no negative impacts to the community and only adds to the housing supply and aesthetic appeal of the neighborhood."
- Several ZAB board members stated that they would not be able, in good conscience, to eliminate or take any existing rent-controlled units off the market during the November 8<sup>th</sup> meeting. However, when addressing this project, they ruled against keeping the rent-controlled unit.
- It was stated by the ZAB that the zoning rules now being applied by the Staff to demand demolition were **not** in place when the building and shed were built in the early 1900's.
- The cottage has existed for 6 years within the footprint of the shed it replaced, in this exact location (as evidenced by fire map records and illustrated by Architect, Ms. Catherine Roha, it is smaller than the shed's concrete pad.
- The November 8<sup>th</sup> staff findings did not support their conclusions and further, the ZAB treated this property differently than others in the City of Berkeley.
- Staff failed to distribute the pictures and substantial information provided, for this applicant, as it did for the applicants of other projects at the same meeting.
- ZAB staff stated that there are no exceptional or extraordinary circumstances or conditions applying to the land or building. Nothing could be further from the truth. The Board members stated that it does have historical precedence. The subject property is unique in that it has a location where an infill unit could and has been added without affecting current residents, impacting adjacent properties, or reducing green space.
- The owners added an infill unit without any negatives at their own cost, to provide much needed housing. During the previous applicant's (John Stevick) application preparation, he personally canvassed the many multi-residential buildings within 300 feet of the subject property. Every conversation he had was concluded with a signature of support. He did not run into a single criticism of the existing cottage. The one and only request presented to him in order to secure support was a letter from the owners of the 84-unit building immediately west expressing support so long as the owners agree that future costs incurred to maintain the retaining wall between the two properties be split. As no objections to the cottage's existence have been presented, we ask that the cottage be legalized as its presence does not impact anyone. (This was not acknowledged at November 8<sup>th</sup> ZAB meeting).
- Further, the ZAB's failure to recognize the added value of the cottage has resulted in a lost opportunity of providing an additional rent-controlled unit to the City of Berkeley.



Planning and Development Department  
Land Use Planning Division

## MEMORANDUM

DATE: November 7, 2018

TO: Zoning Adjustments Board

FROM: Leslie Mendez, Senior Planner

SUBJECT: Use Permit/Variance ZP2018-0021 1722 Walnut Street: Corrections to Staff Report and Findings (Attachment 1)

Staff was made aware that both the staff report and Findings (Attachment 1) that were published in the packet for the above referenced project (Use Permit/Variance ZP2018-0021) were not the final versions.

Below are track change revisions to the staff report. Added text is underlined and deleted text is ~~strikethrough~~.

- On page 8 of the staff report, the final paragraph under Section V. B. Finding #2 should be deleted as follows:

~~*Under the existing legal condition (i.e. eight dwelling units). In addition, is naturally limited to what is lawful (i.e. what zoning allows), and In conclusion, the applicant has not provided evidence that the use of the property in its permitted condition does not preserve the owner's substantial property rights. This finding cannot be made.*~~

- The final paragraph under Section V.B. on page 9 of the staff report should be as follows:

*In summary, the required Variances to approve the illegal dwelling cannot be made as there is no exceptional circumstance on the property (Finding 1), the variance is not necessary for the preservation of substantial property rights (Finding 2), and the project would be generally detrimental (Finding 3).*

The Findings sent out with the packet had the incorrect date, as well as included Conditions that are inapplicable to staff's recommendation to deny the project. For clarification, the corrected Attachment 1 document is attached.



# Z O N I N G A D J U S T M E N T S B O A R D S T A F F R E P O R T

FOR BOARD ACTION  
NOVEMBER 8, 2018

## 1722 Walnut Street

**Use Permit/Variance #ZP2018-0021 to permit a ninth dwelling unit on a lot with an existing two-story, eight unit apartment building.**

### I. Background

#### A. Land Use Designations:

- General Plan: HDR – High Density Residential
- Zoning: R-4 – Multi-Family Residential

#### B. Zoning Permits Required:

- Use Permit to construct a new dwelling unit, under BMC Section 23D.40.030
- Administrative Use Permit (AUP) to reduce the rear yard setback for two or more Main Buildings which contain dwelling units under BMC 23D.40.070.D.1
- Administrative Use Permit (AUP) to reduce the required building separation between two or more main building that contain dwelling units under BMC 23D.40.070.D.2
- Variance to decrease the required left side yard setback below minimum requirement per BMC 23D.40.070.D
- Variance to further increase the non-conforming lot coverage over the maximum requirement per BMC 23D.40.070.E
- Variance to not provide and to further decrease the non-conforming Useable Open Space per dwelling below the minimum requirement per BMC 23D.40.070.F
- Variance to not provide the minimum parking requirement (one space) for a new dwelling unit per BMC 23D.40.080.A

**C. CEQA Determination:** Categorically exempt pursuant to Section 15303 of the CEQA Guidelines (“New Construction or Conversion of Small Structures”).

#### D. Parties Involved:

- Applicant                      John Stevick, 1636 Walnut Street, Berkeley, CA 94709
- Property Owner              Elizabeth Scherer and Glen Stevick, 1636 Walnut Street, Berkeley, CA 94709

Figure 1: Vicinity Map

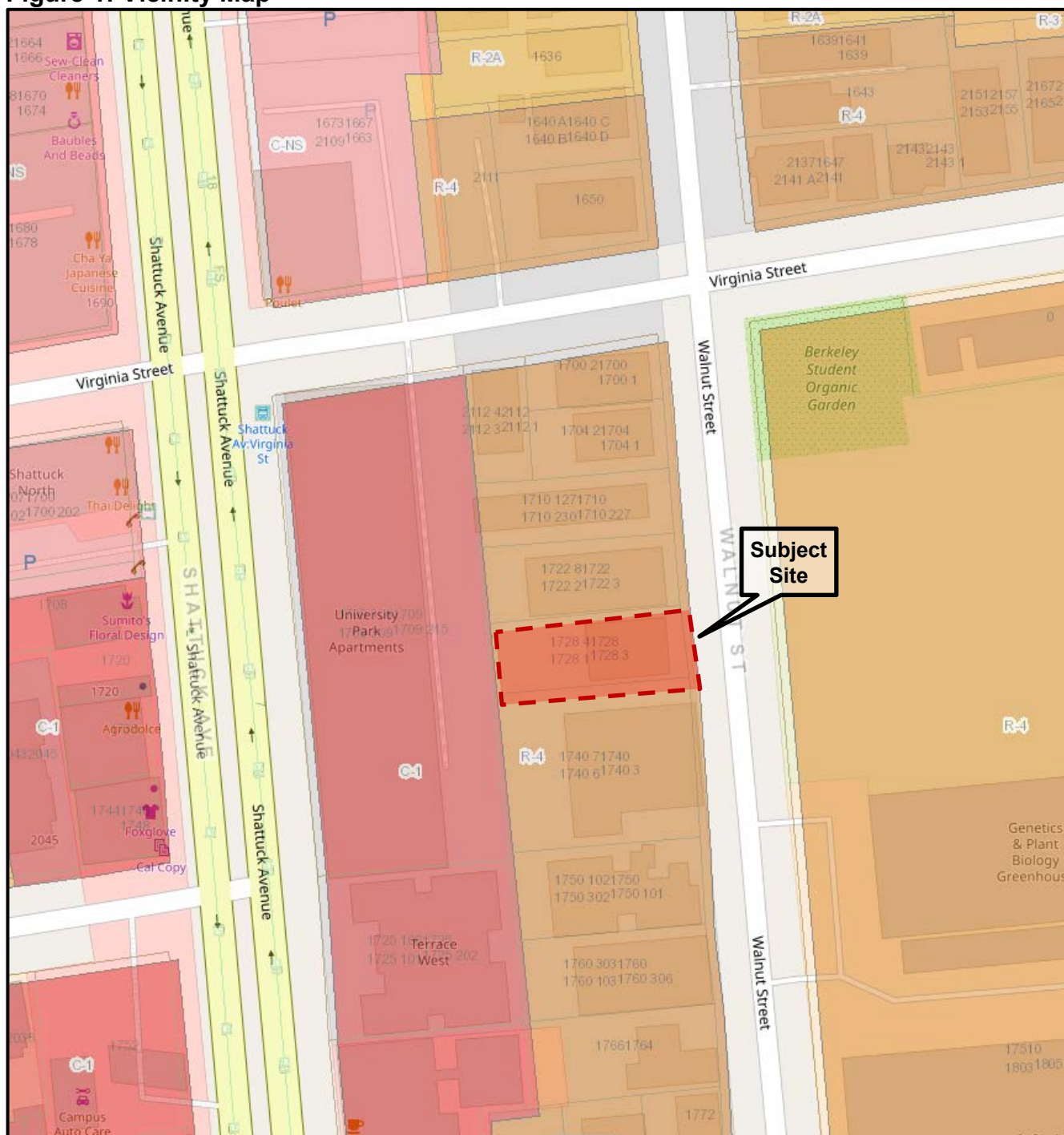
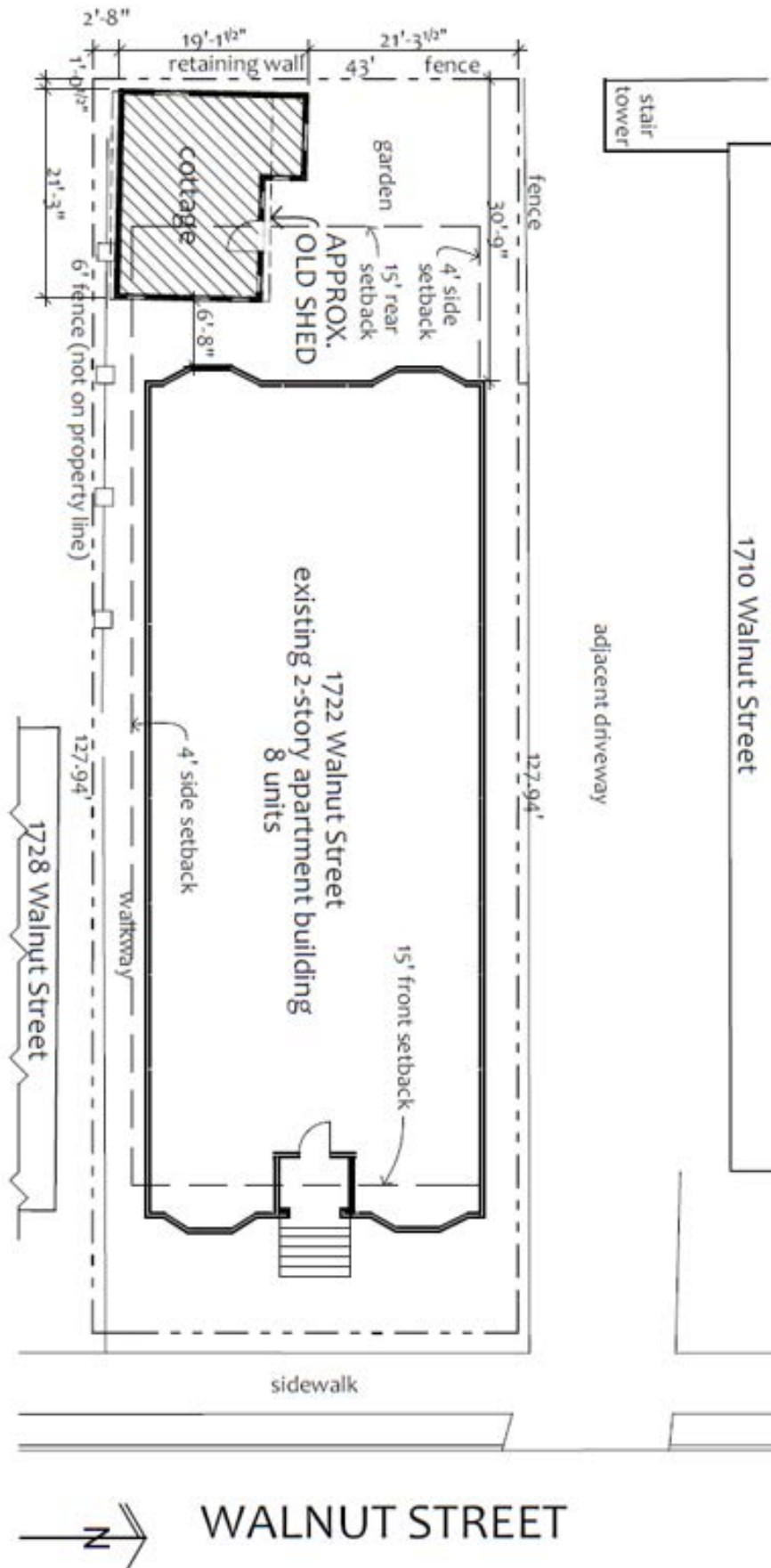

Figure 2: Proposed Site Plan



**Table 1: Land Use Information**

| Location               |       | Existing Use                                 | Zoning District | General Plan Designation |
|------------------------|-------|----------------------------------------------|-----------------|--------------------------|
| Subject Property       |       | Multi-Family                                 | R-4             | High Density Residential |
| Surrounding Properties | North | Multi-Family                                 | R-4             | High Density Residential |
|                        | South | Multi-Family                                 | R-4             | High Density Residential |
|                        | East  | Research, Laboratory<br>(Oxford Tract Farm)  | R-4             | High Density Residential |
|                        | West  | Multi-Family<br>(University Park Apartments) | C-1             | Avenue Commercial        |

**Table 2: Special Characteristics**

| Characteristic                                                                 | Applies to Project? | Explanation                                                                                                               |
|--------------------------------------------------------------------------------|---------------------|---------------------------------------------------------------------------------------------------------------------------|
| Affordable Housing Mitigations for rental housing projects (Per BMC 22.20.065) | No                  | As a project constructing less than five new dwelling units, this applies to the project.                                 |
| Housing Accountability Act (Gov't Code Section 65589.5)                        | Yes                 | As a project use of residential units the HAA applies to the project.                                                     |
| Creeks                                                                         | No                  | There are no creeks in or around the project.                                                                             |
| Density Bonus                                                                  | No                  | The project is requesting a Density bonus.                                                                                |
| Historic Resources                                                             | No                  | The project site does not contain a City Landmark or a known historic resource.                                           |
| Oak Trees                                                                      | No                  | There are no oak trees on the site.                                                                                       |
| Rent Controlled Units                                                          | Yes                 | The eight units in the apartment building are subject to rent control.                                                    |
| Residential Preferred Parking (RPP)                                            | Yes                 | The project site is in RPP Zone F.                                                                                        |
| Seismic Hazards (SHMA)                                                         | No                  | The site is not located in a seismic hazard zone.                                                                         |
| Soil/Groundwater Contamination                                                 | No                  | There is no history of ground water contamination on the site and it is not located in the Environmental Management Area. |
| Transit                                                                        | Yes                 | AC Transit and UC Berkeley Shuttle lines run on Shattuck Avenue and Hearst Avenue, both one block from the project site.  |

**Table 3: Project Chronology**

| Date              | Action                               |
|-------------------|--------------------------------------|
| January 29, 2018  | Application submitted                |
| September 5, 2018 | Application deemed complete          |
| October 25, 2018  | Public hearing notices mailed/posted |
| November 8, 2018  | ZAB hearing                          |

**Table 4: Development Standards**

| Standard<br>BMC Sections 23D.40.070-080 |                   | Existing                      | Proposed Total             | Permitted/<br>Required                                                                                                                                             |
|-----------------------------------------|-------------------|-------------------------------|----------------------------|--------------------------------------------------------------------------------------------------------------------------------------------------------------------|
| Lot Area (sq. ft.)                      |                   | 5,479                         | No change                  | 5,000 min                                                                                                                                                          |
| Gross Floor Area (sq. ft.)              |                   | 5,800                         | 6,146                      | n/a                                                                                                                                                                |
| Dwelling Units                          | Total             | 8                             | 9                          | n/a                                                                                                                                                                |
|                                         | Below Market Rate | 0                             | 0                          | 0 min                                                                                                                                                              |
| Building Height                         | Average (ft.)     | Apartment: 29                 | Cottage: 11.25             | 35 max<br>65 w/UP                                                                                                                                                  |
|                                         | Maximum (ft.)     | Apartment: 30                 | Cottage: 11.25             | n/a                                                                                                                                                                |
|                                         | Stories           | Apartment: 2                  | Cottage: 1                 | 3 max<br>6 w/UP                                                                                                                                                    |
| Building<br>Setbacks (ft.)              | Front             | <b><i>Apartment: 11.7</i></b> | Cottage: 105               | 15 min                                                                                                                                                             |
|                                         | Rear              | Apartment: 31                 | Cottage: 1                 | 15 min<br>AUP to reduce on lot w/ two or<br>more buildings containing dus                                                                                          |
|                                         | Left Side         | Apartment: 5.2                | <b><u>Cottage: 2.2</u></b> | 1st-2 <sup>nd</sup> story: 4 min<br>3 <sup>rd</sup> story: 6 min<br>4 <sup>th</sup> story: 8 min<br>5 <sup>th</sup> Story: 10 min<br>6 <sup>th</sup> story: 12 min |
|                                         | Right Side        | <b><i>Apartment: 3.4</i></b>  | Cottage: 21.3              |                                                                                                                                                                    |
| Lot Coverage (%)                        |                   | <b>60</b>                     | <b><u>61</u></b>           | 45 max<br>(for 2 stories)                                                                                                                                          |
| Usable Open Space (sq. ft.)             |                   | <b>1,098</b>                  | <b><u>990</u></b>          | 1,800 min<br>(200 per du)                                                                                                                                          |
| Automobile Parking                      |                   | <b>0</b>                      | <b><u>0</u></b>            | 9 min<br>(1 per du)                                                                                                                                                |

Items in ***bold italics*** are existing, lawful, non-conforming conditions.

Items in **underlined bold 11 pt. font** are requested Variances.

## II. Project Setting

**A. Neighborhood/Area Description:** The property is located approximately one quarter mile to the northwest of the UC Berkeley campus in an area bound by Shattuck Avenue to the west, Virginia Street to the north, Oxford Street to the east, and Delaware Street to the south. The neighborhood is a combination of commercial businesses along Shattuck Avenue, and numerous multi-family and mid-size (two- to four-story) multi-family buildings along Walnut Street. A large area is dedicated to the Oxford Tract Farm and greenhouses to the east. AC Transit lines 7, 18, and FS run along Shattuck Avenue, and line 67 runs along Oxford Street.

**B. Site Conditions and Background:** The project site is a 5,479-square-foot, rectangular (43' x 127.42') parcel that is developed with an approximately 6,000-square-foot, two-story, eight-unit apartment building that was constructed in 1926. No off-street parking exists on the site. Approximately six years ago, the property owners built a detached cottage (i.e. dwelling unit) without permits in the southwestern (rear left) corner of the property in a location where a shed had been located. The cottage is registered with the Rent Stabilization Board (RSB) along with an unpermitted

basement unit, listed on the RSB website as “Not Available for Rent since 8/1/2017” (<https://www.cityofberkeley.info/RentBoardUnitSearch.aspx>).

As early as 2016, the cottage was listed on Airbnb along with at least five other of the apartments in the main building (see Attachment 4). As the listings are for stays of a minimum of at least 14 days, they do not qualify as short term rentals. Staff raises this point as the applicant statement alludes to the region’s housing crisis. The applicant has written, “The rear cottage in question in a small one-bedroom unit that not only adds to the beauty of the backyard, but to the housing supply as well. As the area is in such short supply of housing, we would very much like to see this unit, which has already been in use for the past six years, be allowed to stay on the market.” Staff wishes to make clear from the current availability of the unit(s) as shown on the Airbnb site, as well as the frequency of the reviews, that these units are not being used as housing for families, or even for students during the school year; the use is more akin to an extended stay hotel.

### III. Project Description

After receiving a Notice of Violation from the Neighborhood Services Enforcement Division (Code Enforcement) in November 2017, the property owners submitted the current project application to the Planning Department for retroactive approval of the ninth dwelling unit on the property. The dwelling unit is located in the 354-square-foot, 11.25-foot tall detached one-bedroom cottage in the rear yard area.

### IV. Community Discussion

**A. Neighbor/Community Concerns:** Prior to submitting this application to the city in January 2018, the applicant installed a pre-application poster at the project site. On October 25, 2018, the City mailed public hearing notices to interested neighborhood organizations, and to property owners and occupants within 300 feet of the project site, and staff posted notices within the neighborhood at three locations.

At the time of this writing, staff has received public comment over the phone from a long time resident of the property, Lisa Klug. She stated that the property seems like a hotel now with people coming in and out; that her name is the only one left on the mailboxes as other residents are transient; that the property owner has offered to buy her out twice, but she turned down the offer; and that the cottage is taking up a large part of the rear yard area. The resident mentioned as a disclosure that she is currently in a lawsuit with the property owner. Ms. Klug subsequently submitted correspondence in opposition to the project that can be found in Attachment 5.

**B. Committee Review:** This project is not subject to committee review.



## V. Issues and Analysis

- A. The Housing Accountability Act:** The Housing Accountability Act §65589.5(j) requires that when a proposed housing development complies with the applicable, objective General Plan and Zoning standards, but a local agency proposes to deny the project or approve it only if the density is reduced, the agency must base its decision on written findings supported by substantial evidence that:
- (1) The development would have a specific adverse impact on public health or safety unless disapproved, or approved at a lower density; and
  - (2) There is no feasible method to satisfactorily mitigate or avoid the specific adverse impact, other than the disapproval, or approval at a lower density.

There are multiple aspects of the proposed development project that do not meet the base regulatory standards of the BMC: 1) off street parking; 2) usable open space; 3) lot coverage; 3) side and rear yard setbacks; and 4) building-to-building separation. Therefore, §65589.5(j) **does not apply** to this project as currently proposed.

- B. Variances:** The project would require four Variances from the development standards of the R-4 District: (1) to permit a 2.2-foot side yard setback where a minimum of 4 feet is required for a first story (BMC 23D.40.070.D); (2) to not provide the required off-street parking for the new dwelling (BMC 23.D.40.080.A); (3) to further increase the existing non-conforming 60% lot coverage to 61% where a maximum of 45% is permissible for a property with a two-story building (BMC 23D.40.070.E); and (4) to not provide the required Useable Open Space and further reduce the existing non-8

Finding #1: There are exceptional or extraordinary circumstances or conditions applying to the land, building or use referred to in the application, which circumstances or conditions do not apply generally to land, buildings and/or uses in the same District.

In support of this Finding the applicant has provided the following evidence:

*“This building is within 0.5 miles of Downtown BART, 0.1 miles of the closes bus stop, 0.2 miles of the closest trans-bay bus stop, and 0.2 miles of the closed UC Berkeley shuttle. The existing cottage in question has been in existence for over 6 years and serves a relaxing and tranquil respite from the 4+ story buildings surround it and the greater and ever expanding Downtown Berkeley.”*

Although the statements, some subjective, may be true, they do not highlight how they represent exceptional or extraordinary circumstance applying to this property that do not generally apply to other properties in the same zoning district. In fact, access to the existing transportation system applies to all the properties in the vicinity. Staff also does not believe that the existence of the illegal unit qualifies as an exceptional or extraordinary condition as any property owner could follow through with unpermitted development. In addition, staff cannot identify any other exception or extraordinary condition on the site that support this Finding to permit non-compliance with the development standards that apply to all other properties within the District. This finding cannot be made.

Finding #2: The granting of the application is necessary for the preservation and enjoyment of substantial property rights of the subject property's owner.

In support of this Finding, the applicant provided the following evidence:

*"The surrounding neighborhood is very dense relative to the majority of Berkeley and becoming increasingly so each year with new, large-scale mixed use projects continuing to go up. We are simply asking for the same kind of coverage that neighboring lots enjoy on the very same block. Many other buildings in the immediate vicinity are over density as can be seen by referring to the attached vicinity map."*

Due to the age of buildings and the various changes made over time to the Zoning Ordinance, many buildings and sites are non-conforming in this District to varying degrees, including the subject site. This statement, however, does not address the required finding. Staff interprets property rights as a property owner's ability to use his or her property in a manner consistent with the applicable provisions of the Ordinance; the application cannot be used to support any condition that a property is in, or made to be, that is unlawful. Nor is it related to the financial viability or profitability of a property. The applicant has not provided evidence that the use of the property with its unpermitted condition is necessary for the preservation and enjoyment of substantial property rights. In fact, the property owners purchased, and have managed, a property with eight lawful, rental dwelling units for several years. This finding cannot be made.

Under the existing legal condition (i.e. eight dwelling units). In addition, is naturally limited to what is lawful (i.e. what zoning allows), and In conclusion, the applicant has not provided evidence that the use of the property in its permitted condition does not preserve the owner's substantial property rights. This finding cannot be made.

Finding #3: The establishment, maintenance or operation of the use or the construction of a building, structure or addition thereof, to be approved will not, under the circumstances of the particular case, materially affect adversely the health or safety of persons residing or working in the neighborhood of the property of the applicant and will not, under the circumstances of the particular case, be materially detrimental to the public welfare or injurious to property or improvements in said neighborhood; and that the granting of the Variance will promote the municipal health, welfare and safety and benefit the City as a whole.

In support of this Finding, the applicant has submitted the following evidence:

*"It is our pleasure to provide an additional safe and habitable living space within walking distance of Downtown Berkeley and UC Berkeley campus. We find that the cottage actually enhances the backyard aesthetic and compliments [sic] the garden for all property residents in comparison to the dilapidated shed that stood in the cottages place before."*

Staff agrees that the dwelling unit is aesthetically pleasing, and that at its current height and massing, has minimal impact to air, views, or light of the existing or neighboring properties. In addition, if the project were to be approved, the project would be conditioned to obtain a building and occupancy permit ensuring compliance with all current building and fire codes, thereby removing any potential life/safety impacts to

adjacent properties as well as guests and residents of the subject property. However, one of the purposes of the R-4 District is to “*Make available housing for persons who desire both convenience of location and a reasonable amount of Useable Open Space.*” The project site is currently non-conforming for Useable Open Space and exceeds allowable lot coverage, the proposed project exacerbates both these conditions. The project, therefore, also conflicts with the purposes of the Zoning Ordinance in that it exceed the appropriate intensity of development of land and buildings through excessive lot coverage (BMC 23A.04.030.C) and it does not provide for adequate usable open space, off-street parking (BMC 23A.04.030.E). This Finding cannot be made.

Finding #4: Any other variance findings required by the Section of the Ordinance applicable to that particular Variance.

This Finding is not applicable to the Variance requests.

In summary, the required Variances to approve the illegal dwelling cannot be made as there is no exceptional circumstance on the property (Finding 1), the variance is not necessary for the preservation of substantial property rights (Finding 2), and the project be generally detrimental (Finding 3),

**C. Reduction of Rear Yard Setback and Building to Building Separation:** The project proposes a 1-foot rear yard setback where a minimum of 15 feet is required and proposes a 6.75-foot building to building separation, where a minimum of 8 feet is required. Section 23D.40.070.1 and 2 of the Zoning Ordinance, allow both the rear yard and the building separation to be reduced with approval of an Administrative Use Permit (AUP) for two or more Main Buildings which contain Dwelling Units as applies to the subject project. In addition, as described in Variance Finding 3 above, in its current location, the cottage does not have detrimental impacts to air, light, or views. The findings to approve these reductions in the development standards can be made.

## VI. Recommendation

Because of the project’s inconsistency with the Zoning Ordinance and General Plan, staff recommends that the Zoning Adjustments Board

**DENY** Use Permit/Variance #ZP2018-0021 pursuant to Section 23B.32.040 and subject to the attached Findings (see Attachment 1).

### Attachments:

1. Findings
2. Project Plans, dated April 18, 2018
3. Notice of Public Hearing
4. Airbnb Listings, downloaded October 18, 2018
5. Correspondence Received (at the time of publication of this report)

**Staff Planner:** Leslie Mendez, LMendez@cityofberkeley.info, (510) 981-7426



Planning and Development Department  
Land Use Planning Division

Our ref.: PLN2017-0007

April 3, 2017

John Stevick  
1636 Walnut St.  
Berkeley, CA 94709

Dear Mr. Stevick,

**RE: Zoning Research Letter – 1722 Walnut St., Berkeley, 058 217700600**

This letter responds to your request for a Zoning Research Letter for the property with the above address. The following letter provides zoning information and the aforementioned address.

**1) CURRENT ZONING**

This property is located in the Multi-Family Residential District (R-4). The property is subject to all applicable provisions in Berkeley Municipal Code Chapter 23D.40 (see attachment 1).

**2) PROPERTY HISTORY**

The City's Finance Card indicates the construction of a two-story, eight-unit apartment building on this site; there is no note of a garage (see attachment 2). City Staff has reviewed zoning permit and building permit files for the property and have found no record approving or otherwise of a structure in the southwest corner. While the Sanborn Insurance map shows an auto garage at the southwest corner of the lot, again, it is not found in any City records and it is unclear how this garage would be accessed.

In 1989 a permit was granted to increase height of building from three stories to four stories and 38.5 feet. However, this was not exercised and the City has no records of building permits.

**3) LEGAL USE OF THE SUBJECT PROPERTY**

Based on the information available to the department, the legal use of the subject property is a two-story apartment with four units on the first floor, and four units on the second floor (total of eight legal dwelling units).

**4) ACCESSORY DWELLING UNIT (ADU)**

An ADU is defined in Berkeley Municipal Code Section 23.F.04.010 as follows: A second unit on a lot which is occupied by one Single Family Dwelling and zoned single family residential (R-1), or a unit approved under the provisions for Accessory Dwelling Units on a lot which is occupied by one Single Family Dwelling and zoned R-1A, R-2, R-2A, R-3, R-4, R-5, R-S OR R-SMU. The property is zoned as R-4 and contains an eight-unit apartment building, and is not eligible for an ADU.

**5) CONFORMING WITH CURRENT ZONING REQUIREMENTS**

To legalize the “rental cottage” as a dwelling unit, a Use Permit with Public Hearing would be required; to legalize this as a storage structure, a Zoning Certificate would be required. However, the project site and new structure is subject to the development standards listed in BMC 23D.40.070, which includes height limits, building setbacks, building separations, lot coverage and open space per dwelling unit. If certain standards cannot be met, in some instances they may be reduced subject to an Administrative Use Permit. However, some standards, such as lot coverage, can only be modified with a Variance. Please refer to BMC Chapter 23B.44, Variances, for information on the application and hearing process as well as the Findings that are required. Please note that Variance Findings are often difficult to make.

The determinations in this letter are based on a review of the facts available to me at this time, excepting additional information that may become available in the future. While this letter is true to the best of my knowledge, it shall not be considered legally binding in any way.

If you have additional questions, please contact Camille Jackson with Land Use Planning Division by calling him directly at (510) 981-7471

Sincerely,

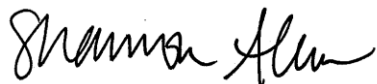

Shannon Allen, AICP, Principal Planner

Prepared by Camille Jackson, Land Use Planning Division Intern

Attachments (2)

Attachment-1 Multi-Family Residential District Provisions

Attachment -2 Finance Card

**Chapter 23D.40**

**R-4 MULTI-FAMILY RESIDENTIAL DISTRICT PROVISIONS**

**Sections:**

- 23D.40.010**    **Applicability of Regulations**
- 23D.40.020**    **Purposes**
- 23D.40.030**    **Uses Permitted**
- 23D.40.040**    **Special Provisions -- Design Review**
- 23D.40.050**    **Reserved**
- 23D.40.060**    **Reserved**
- 23D.40.070**    **Development Standards**
- 23D.40.080**    **Parking -- Number of Spaces**
- 23D.40.090**    **Findings**

**Section 23D.40.010    Applicability of Regulations**

The regulations in this Chapter shall apply in all R-4 Districts. In addition, the general provisions in Sub-title 23C shall apply. Where the H District overlays a property so as to be classified R-4(H), the Hillside District provisions of Chapter 23E.96 shall also apply. (Ord. 6478-NS § 4 (part), 1999)

**Section 23D.40.020    Purposes**

The purposes of the Multi-family Residential (R-4) Districts are to:

- A. Implement Master Plan policy by encouraging development of relatively high density residential areas;
- B. Make available housing for persons who desire both convenience of location and a reasonable amount of Usable Open Space;
- C. Protect adjacent properties from unreasonable obstruction of light and air;
- D. Permit the construction of residential structures, such as residential hotels, and hotels, which will provide housing opportunities for transient or seasonal residents;
- E. Permit the construction of institutional and office uses when such will not be detrimental to the immediate neighborhood. (Ord. 6478-NS § 4 (part), 1999)

**Section 23D.40.030    Uses Permitted**

The following table sets forth the Permits required for each listed item. Each use or structure shall be subject to either a Zoning Certificate (ZC), an Administrative Use Permit (AUP), a Use Permit approved after a public hearing (UP(PH)) or is Prohibited.

| <i>Table 23D.40.030</i>         |                       |                                      |
|---------------------------------|-----------------------|--------------------------------------|
| <b>Use and Required Permits</b> |                       |                                      |
| <b>Use</b>                      | <b>Classification</b> | <b>Special Requirements (if any)</b> |
| <b>Uses Permitted</b>           |                       |                                      |
| Child Care Centers              | UP(PH)                |                                      |
| Clubs, Lodges                   | UP(PH)                |                                      |

| <i>Table 23D.40.030 (Continued)</i>                                                                                                                                                                                        |                             |                                                                                                                        |
|----------------------------------------------------------------------------------------------------------------------------------------------------------------------------------------------------------------------------|-----------------------------|------------------------------------------------------------------------------------------------------------------------|
| <b>Use and Required Permits</b>                                                                                                                                                                                            |                             |                                                                                                                        |
| <b>Use</b>                                                                                                                                                                                                                 | <b>Classification</b>       | <b>Special Requirements (if any)</b>                                                                                   |
| Community Care Facilities/Homes<br>Changes of Use<br>New Construction                                                                                                                                                      | ZC<br>UP(PH)                | Subject to parking requirements. See Section 23D.40.080.A                                                              |
| Community Centers                                                                                                                                                                                                          | UP(PH)                      |                                                                                                                        |
| Dwelling Units, Single-family, Duplex, or Multi-Family, subject to R-4 Standards<br><br>Residential Additions (up to 15% of lot area or 600 square feet, whichever is more restrictive)<br><br>Major Residential Additions | UP(PH)<br><br>ZC<br><br>AUP | See Section 23D.40.070 for restrictions.<br><br>See definition in Sub-title F. Denial subject to Section 23D.40.090.B. |
| Group Living Accommodations subject to R-4 standards                                                                                                                                                                       | UP(PH)                      |                                                                                                                        |
| Hospitals                                                                                                                                                                                                                  | UP(PH)                      | Subject to parking requirements. See Section 23D.40.080.A                                                              |
| Hotels                                                                                                                                                                                                                     | UP(PH)                      | Subject to parking requirements; see Section 23D.40.080.A. Also subject to Design Review; see Section 23D.40.040       |
| Libraries                                                                                                                                                                                                                  | UP(PH)                      | Subject to parking requirements. See Section 23D.40.080.A                                                              |
| Nursing Homes                                                                                                                                                                                                              | UP(PH)                      | Subject to parking requirements. See Section 23D.40.080.A                                                              |
| Offices                                                                                                                                                                                                                    | UP(PH)                      | Subject to parking requirements. See Section 23D.40.080.A. Also subject to design review; see Section 23D.40.040.      |
| Parking Lots                                                                                                                                                                                                               | UP(PH)                      | Subject to Section 23D.12.090                                                                                          |
| Parks and Playgrounds                                                                                                                                                                                                      | ZC                          |                                                                                                                        |
| Public Safety and Emergency Services                                                                                                                                                                                       | UP(PH)                      |                                                                                                                        |
| Religious Assembly Uses                                                                                                                                                                                                    | UP(PH)                      |                                                                                                                        |
| Schools, Public or Private                                                                                                                                                                                                 | UP(PH)                      |                                                                                                                        |
| Senior Congregate Housing<br>Six or fewer persons<br>Seven or more persons<br>New Construction                                                                                                                             | ZC<br>AUP<br>UP(PH)         | Changes of use from an existing dwelling unit                                                                          |
| <b>Accessory Uses and Structures</b>                                                                                                                                                                                       |                             |                                                                                                                        |
| Accessory Buildings or Structures                                                                                                                                                                                          | ZC                          | Must satisfy the requirements of Chapter 23D.08                                                                        |
| If has either habitable space and/or exceeds the requirements under Chapter 23D.08                                                                                                                                         | AUP                         |                                                                                                                        |
| When located on a vacant lot without a Main Building                                                                                                                                                                       | AUP                         |                                                                                                                        |
| Accessory Dwelling Units in compliance with Section 23D.10.040                                                                                                                                                             | ZC                          |                                                                                                                        |

| <i>Table 23D.40.030 (Continued)</i>                                                      |                       |                                                                                                                                                                                                                                               |
|------------------------------------------------------------------------------------------|-----------------------|-----------------------------------------------------------------------------------------------------------------------------------------------------------------------------------------------------------------------------------------------|
| <b>Use and Required Permits</b>                                                          |                       |                                                                                                                                                                                                                                               |
| <b>Use</b>                                                                               | <b>Classification</b> | <b>Special Requirements (if any)</b>                                                                                                                                                                                                          |
| Accessory Dwelling Unit which does not comply with requirements under Section 23D.10.040 | AUP                   | Subject to making of applicable findings set forth in Section 23D.10.060                                                                                                                                                                      |
| Child Care, Family Day Care                                                              |                       |                                                                                                                                                                                                                                               |
| Small Family Day Care Homes of eight or fewer children                                   | ZC                    |                                                                                                                                                                                                                                               |
| Large Family Day Care Homes of nine to 14 children                                       | AUP                   |                                                                                                                                                                                                                                               |
| Fences                                                                                   |                       |                                                                                                                                                                                                                                               |
| Six ft. or less in height                                                                | ZC                    |                                                                                                                                                                                                                                               |
| Exceeding six ft. in height                                                              | AUP                   | In required setbacks                                                                                                                                                                                                                          |
| Home Occupations                                                                         |                       |                                                                                                                                                                                                                                               |
| Low Impact                                                                               | ZC                    | If the requirements of Section 23C.16.020 are met                                                                                                                                                                                             |
| Moderate Impact, teaching-related                                                        | AUP                   | Subject to the requirements of Section 23C.16.030.A                                                                                                                                                                                           |
| Moderate Impact                                                                          | UP(PH)                | Subject to the requirements of Section 23C.16.030.B                                                                                                                                                                                           |
| Hot Tubs, Jacuzzis, Spas                                                                 | AUP                   | See Section 23D.08.060.C                                                                                                                                                                                                                      |
| Stables for Horses                                                                       | AUP                   |                                                                                                                                                                                                                                               |
| Stores and Shops (Incidental to another Use)                                             | UP(PH)                | Contained within a building with no street access and no displays or merchandise visible from the street                                                                                                                                      |
| <b>Miscellaneous Uses</b>                                                                |                       |                                                                                                                                                                                                                                               |
| Cemeteries, Crematories, Mausoleums                                                      | Prohibited            |                                                                                                                                                                                                                                               |
| Columbaria                                                                               | AUP                   | Allowed with a ZC if incidental to a Community and Institutional Use, limited to 400 niches, and no more than 5% of the subject property area. When located outside of the main building columbaria structures are subject to Chapter 23D.08. |
| Commercial Excavation                                                                    | UP(PH)                | Including earth, gravel, minerals, or other building materials including drilling for, or removal of, oil or natural gas                                                                                                                      |
| Emergency Shelter                                                                        |                       | Such shelters may operate only during the wet weather season from November 15 through April 15. See Chapter 23C.10.                                                                                                                           |
| Up to 15 beds                                                                            | ZC                    |                                                                                                                                                                                                                                               |
| More than 15 beds                                                                        | UP(PH)                |                                                                                                                                                                                                                                               |
| Public Utility Substations, Tanks                                                        | UP(PH)                |                                                                                                                                                                                                                                               |
| Wireless Telecommunications Facilities                                                   |                       |                                                                                                                                                                                                                                               |
| Microcell Facilities                                                                     | AUP                   | Subject to the requirements and findings of Section 23C.17.100                                                                                                                                                                                |
| All Other Telecommunication Facilities                                                   | UP                    | Subject to the requirements and findings of Section 23C.17.100                                                                                                                                                                                |



|                                     |                                               |                                      |
|-------------------------------------|-----------------------------------------------|--------------------------------------|
| <i>Table 23D.40.030 (Continued)</i> |                                               |                                      |
| <b>Use and Required Permits</b>     |                                               |                                      |
| <b>Use</b>                          | <b>Classification</b>                         | <b>Special Requirements (if any)</b> |
| <b>Legend:</b>                      |                                               |                                      |
| ZC -- Zoning Certificate            | UP(PH) -- Use Permit, public hearing required |                                      |
| AUP -- Administrative Use Permit    | Prohibited -- Use not permitted               |                                      |

(Ord. 7426-NS § 25, 2015; Ord. 7322-NS § 2, 2013; Ord. 7210-NS § 14, 2011; Ord. 7155 § 7, 2010; Ord. 7129-NS § 7, 2010; Ord. 6949-NS § 14 (part), 2006; Ord. 6909-NS § 7 (part), 2006; Ord. 6854-NS § 11 (part), 2005; Ord. 6763-NS § 25 (part), 2003; Ord. 6671-NS § 6, 2001; Ord. 6658-NS § 1, (2001); 6644-NS § 1, 2001; Ord. 6478-NS § 4 (part), 1999)

**Section 23D.40.040 Special Provisions -- Design Review**

Commercial and mixed use projects shall be subject to Design Review as set forth in Chapters 23E.08 and 23E.12. (Ord. 6478-NS § 4 (part), 1999)

**Section 23D.40.050 Reserved**

*Reserved.* (Ord. 7210-NS § 15, 2011; Ord. 6658-N.S. § 2, 2001)

**Section 23D.40.060 Reserved**

*Reserved.* (Ord. 7426-NS § 26, 2015; Ord. 6763-NS § 26 (part), 2003)

**Section 23D.40.070 Development Standards**

- A. No lot of less than 5,000 square feet may be created.
- B. No more than one person who resides in a Group Living Accommodation use shall be allowed for each 350 square feet of lot area. One additional person who resides in a Group Living Accommodation use may also be allowed for any remaining lot area which may be less than 350 square feet, but not less than 200 square feet in area.
- C. Each Main Building shall be limited in height as follows:

|                           | <u>Height limit average (ft.)</u> | <u>Stories limit (number)</u> |
|---------------------------|-----------------------------------|-------------------------------|
| Main Building             | 35*                               | 3*                            |
| All Residential Additions | 16**                              | Not Applicable                |

\* Main Buildings may exceed 35 ft. and three stories in height, to a height of, but not exceeding, 65 ft. and six stories subject to obtaining a Use Permit  
 \*\* The Zoning Officer may issue an Administrative Use Permit to allow residential additions to exceed 16 feet in average height, up to the district limit.

- D. Each Main Building shall be set back from its respective lot lines, and shall be separated from one another, in accordance with the following limits:

|     | <u>Yard location</u> |              |              |             | <u>Building separation*</u> |
|-----|----------------------|--------------|--------------|-------------|-----------------------------|
|     | <u>Story</u>         | <u>Front</u> | <u>Rear*</u> | <u>Side</u> |                             |
| 1st | 15                   | 15           | 4            | 6           | 8                           |

| Story | Yard location |       |      |             | Building separation* |
|-------|---------------|-------|------|-------------|----------------------|
|       | Front         | Rear* | Side | Street side |                      |
| 2nd   | 15            | 15    | 4    | 8           | 12                   |
| 3rd   | 15            | 15    | 6    | 10          | 16                   |
| 4th   | 15            | 17    | 8    | 12          | 20                   |
| 5th   | 15            | 19    | 10   | 14          | 24                   |
| 6th   | 15            | 21    | 12   | 15          | 28                   |

\*See Sections 23D.40.070.D.1 and 2 for yard and building separation reductions

- For two or more Main Buildings which contain Dwelling Units, the Rear Yard may be reduced subject to obtaining an Administrative Use Permit.
- For two or more Main Buildings which contain Dwelling Units, the required building separation may be reduced subject to Administrative Use Permit.

E. Maximum lot coverage may not exceed the following coverage percentages:

| Main Building Height (stories) | Lot Coverage Area (%)     |             |
|--------------------------------|---------------------------|-------------|
|                                | Interior and Through Lots | Corner Lots |
| 1 or 2                         | 45                        | 50          |
| 3                              | 40                        | 45          |
| 4 through 6                    | 35                        | 40          |

F. Each lot shall contain the following minimum Usable Open Space area: for each Dwelling Unit, 200 square feet; for each person who resides in a Group Living Accommodation use, 90 square feet. (Ord. 6949-NS § 15 (part), 2006; Ord. 6478-NS § 4 (part), 1999)

**Section 23D.40.080 Parking -- Number of Spaces**

A. A lot shall contain the following minimum number of Off-street Parking Spaces:

| Parking Required                                                                                        |                                                                                       |
|---------------------------------------------------------------------------------------------------------|---------------------------------------------------------------------------------------|
| Use                                                                                                     | Number of spaces                                                                      |
| Dormitories; Fraternity and Sorority Houses; Rooming and Boarding Houses; and Senior Congregate Housing | One per each five residents, plus one for manager                                     |
| Dwellings, Multiple (fewer than ten)                                                                    | One per unit (75% less for seniors, see Section C below)                              |
| Dwellings, Multiple (Ten or more)                                                                       | One per 1,000 sq. ft. of gross floor area (75% less for seniors, see Section C below) |
| Dwellings, One and Two Family                                                                           | One per unit*                                                                         |
| Employees                                                                                               | One per two non-resident employees for a Community Care Facility**                    |
| Hospitals                                                                                               | One per each four beds, plus one per each three employees                             |
| Hotels                                                                                                  | One per each three guest rooms, plus one per each three employees                     |
| Libraries                                                                                               | One per 500 sq. ft. of floor area that is publicly accessible                         |

| <b>Parking Required</b>                                                                                                                                                                                                                                                                                                                                                                                                                    |                                                                                |
|--------------------------------------------------------------------------------------------------------------------------------------------------------------------------------------------------------------------------------------------------------------------------------------------------------------------------------------------------------------------------------------------------------------------------------------------|--------------------------------------------------------------------------------|
| <u>Use</u>                                                                                                                                                                                                                                                                                                                                                                                                                                 | <u>Number of spaces</u>                                                        |
| Nursing Homes                                                                                                                                                                                                                                                                                                                                                                                                                              | One per each five residents, plus one per each three employees                 |
| Offices, Medical                                                                                                                                                                                                                                                                                                                                                                                                                           | One per 300 sq. ft. of gross floor area                                        |
| Offices, Other                                                                                                                                                                                                                                                                                                                                                                                                                             | One per 400 sq. ft. of gross floor area; (may be reduced, see Section D below) |
| <p>* This also shall include Accessory Dwelling Units. An application for an Accessory Dwelling Unit that does not meet this standard may apply for an administrative use permit to waive this requirement subject to a special finding under Section 23D.10.060.B.</p> <p>**This requirement does not apply to those Community Care Facilities which under state law must be treated in the same manner as a single family residence.</p> |                                                                                |

- B. Other uses requiring Use Permits, including, but not limited to, Child Care Centers, Clubs, Lodges and community centers, shall provide the number of Off-street Parking Spaces determined by the Board based on the amount of traffic generated by the particular use and comparable with specified standards for other uses.
- C. For multiple dwellings where the occupancy will be exclusively for persons over the age of 62, the number of required Off-street Parking Spaces may be reduced to 25% of what would otherwise be required for multiple family dwelling use, subject to obtaining a Use Permit.
- D. For offices, other than medical offices, the Board may reduce the parking requirement from one Off-street Parking Space per 400 square feet of gross floor area to a minimum of one parking space per 800 square feet of gross floor area, subject to making the required finding under Section 23D.40.090.C. In addition, any parking supplied jointly with multiple family residential uses shall be subject to the requirements set forth in Section 23D.12.060.B.
- E. Senior Congregate Housing, Hotels, Hospitals, Nursing Homes, Offices (including Medical Offices) and Schools, when having a total gross floor area exceeding 10,000 square feet, shall satisfy the requirements of Chapter 23E.32 and the following requirements:
  - 1. Off-street loading spaces at the ratio of one space for the first 10,000 square feet of gross floor area.
  - 2. Off-street loading spaces at the ratio of one space for each additional 40,000 square feet of gross floor area of above the 10,000 square feet. (Ord. 7426-NS § 27, 2015; Ord. 6763-NS § 27 (part), 2003; Ord. 6478-NS § 4 (part), 1999)

**Section 23D.40.090 Findings**

- A. In order to approve any Permit under this chapter, the Zoning Officer or Board must make the finding required by Section 23B.32.040. The Zoning Officer or Board must also make any findings required by the following paragraphs of this section to the extent applicable. If the Zoning Officer or Board makes the applicable finding required by the following paragraph of this section then the permit shall be denied.
- B. To deny a Use Permit for a major residential addition or residential addition subject to 23D.40.070 the Zoning Officer or Board must find that although the proposed residential addition satisfies all other standards of this Ordinance, the addition would unreasonably obstruct sunlight, air or views.
- C. The reduction in the parking requirement is justified, in this particular case, because of a reduced amount of direct contact with clients, visitors or the general public. (Ord. 7426-NS § 28, 2015; Ord. 6980-NS § 7 (part), 2007; Ord. 6763-NS § 28 (part), 2003; Ord. 6478-NS § 4 (part), 1999)

Address

1722 Walnut

Page 36 of 39

Book 8

Par. No.

6

Block 2177

Surveyed by

Date

Remarks

ATTACHMENT 1

ATTACHMENT 2

| Date | Imp. R.C. | % Gd | Table | N.R.C.L.D. | Obs. etc. | Adj. R.C.L.D. | Building Department Records                                              |                        |                     |  |  |
|------|-----------|------|-------|------------|-----------|---------------|--------------------------------------------------------------------------|------------------------|---------------------|--|--|
| 27   | 25346     | 55   | 45    | —          | —         | 13940Y        | Permit for                                                               | Apts                   | Alt                 |  |  |
|      |           |      |       |            |           |               | Permit No.                                                               | 26096                  | 31942               |  |  |
| 38   | 54353     | 47   | 50    |            |           | 25545         | Year Built                                                               | 1926                   | 9-24-28             |  |  |
|      |           |      |       |            |           |               | Amount                                                                   | \$17,500 <sup>00</sup> | \$350 <sup>00</sup> |  |  |
|      |           |      |       |            |           |               | Additions, Alterations, etc.                                             |                        |                     |  |  |
|      |           |      |       |            |           |               | #93404 10/13/61 \$3000. REPLACE PART OF FOUNDATION. 1-25-62 COMPLETE-LDB |                        |                     |  |  |
|      |           |      |       |            |           |               | #113294-1/3/69-\$1,000 <sup>00</sup> -FIRE REPAIR                        |                        |                     |  |  |

## Assessment Record

|         |      |   |  |  |  |
|---------|------|---|--|--|--|
| 1949-50 | 7950 | ✓ |  |  |  |
| 1951-52 | 7780 | ✓ |  |  |  |
| 1956-57 | 7780 | ✓ |  |  |  |
| 1962-63 | 7950 | ✓ |  |  |  |
|         |      |   |  |  |  |
|         |      |   |  |  |  |

Remarks, Reappraisals, etc.

Use Type *Att. 2* of 30 Stories *2* Constr. Class. *26-2*  
 Foundation *Av. Conc.* Excavation *ATTACHMENT 4*  
 Structural *Av. F.C.* Grade \_\_\_\_\_  
 Exterior Walls *Stucco* Windows *Wd. Sash*  
 Roof Material *T & G* Type *Flat* Pitch \_\_\_\_\_

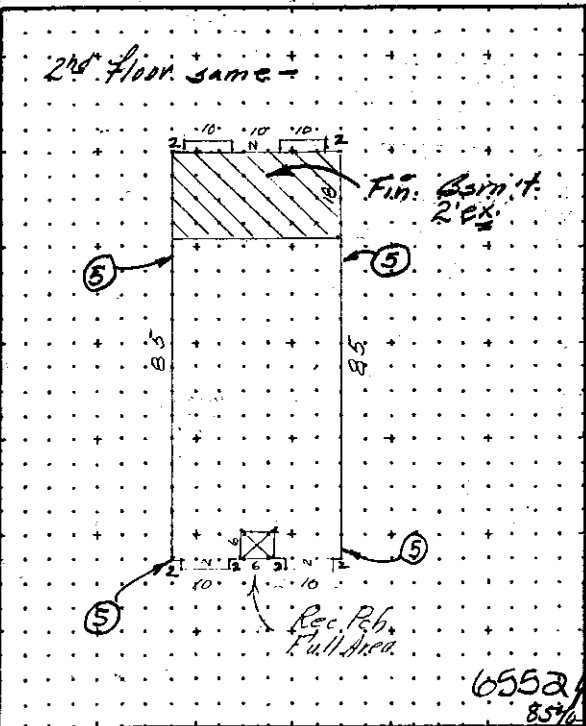

| Rooms       | ROOM & FINISH DETAIL |   |   |   |     |              |      |                 |       |         | Plumbing Detail |         |
|-------------|----------------------|---|---|---|-----|--------------|------|-----------------|-------|---------|-----------------|---------|
|             | Floors               |   |   |   |     | Floor Finish | Trim | Interior Finish |       | Fixture | No.             |         |
|             | B                    | 1 | 2 | 3 | Typ |              |      | Top             | Walls |         |                 | Ceiling |
| Ent. Hall   |                      | 1 | 1 |   |     |              | P    | P               | Plast |         | B               |         |
| Living Rm.  |                      | 4 | 4 |   |     |              | Wd   | all             | all   |         | S               |         |
| Dining Rm.  |                      |   |   |   |     |              |      |                 |       |         | W               |         |
| Kitchen Nk. |                      | 4 | 4 |   |     |              | P    |                 |       |         | L               |         |
| Breakfast   |                      |   |   |   |     |              |      |                 |       |         | S               |         |
| Study       |                      |   |   |   |     |              |      |                 |       |         | W               |         |
| Bed Rm.     |                      |   |   |   |     |              |      |                 |       |         | A               |         |
| Bath        |                      | 4 | 4 |   |     |              | Tile |                 |       |         | 50 501          |         |
| Laundry     |                      |   |   |   |     |              |      |                 |       |         | F               |         |
| Recreation  |                      |   |   |   |     |              |      |                 |       |         | C               |         |
| Furnace     |                      | 1 |   |   |     |              | Conc |                 |       |         | Chimney         |         |
| Garage      |                      |   |   |   |     |              |      |                 |       |         | Patent Flue     |         |

| COMPUTATIONS       |       |         |          | Year            |                        | Year 63-64   |      | Year    |      |
|--------------------|-------|---------|----------|-----------------|------------------------|--------------|------|---------|------|
| Unit               | Area  | Unit C. | Cost     | Unit C.         | Cost                   | Unit C.      | Cost | Unit C. | Cost |
| 1st floor          | 29.70 | 7.11    | 12 2 07  | 846             | 25 12 6                |              |      |         |      |
| 2nd                | 29.70 | 5.49    | 10 3 6 3 | 719             | 2 1 3 5 4              |              |      |         |      |
| Fin. Bsm't.        | 6.12  | 2.00    | 12 2 4   | 549             | 3 3 5 9                |              |      |         |      |
| Heat 5940 #        |       |         | 15 5 0   | 76              | 4 5 1 4                |              |      |         |      |
| Misc. Equipment    |       |         |          |                 |                        |              |      |         |      |
| <b>TOTAL R. C.</b> |       |         |          | <b>25 3 4 6</b> | <b>R. C. 5 4 3 5 3</b> | <b>R. C.</b> |      |         |      |

Misc. Structures—Garages, etc.

| Type | Size | Ext. | Rf. | Int. | Flr. | Area | At | Cost |
|------|------|------|-----|------|------|------|----|------|
| x    |      |      |     |      |      |      |    |      |
| x    |      |      |     |      |      |      |    |      |
| x    |      |      |     |      |      |      |    |      |
| x    |      |      |     |      |      |      |    |      |

6552  
 85%  
 65%



Administrative Record  
ZAB Appeal:  
1722 Walnut Street

This attachment is on file and available for review at the City Clerk Department, or can be accessed from the City Council Website. Copies of the attachment are available upon request.

**City Clerk Department**  
2180 Milvia Street  
Berkeley, CA 94704  
(510) 981-6900

or from:

**The City of Berkeley, City Council's Web site**  
<http://www.cityofberkeley.info/citycouncil/>

ATTACHMENT 7

**NOTICE OF PUBLIC HEARING-BERKELEY CITY COUNCIL  
SCHOOL DISTRICT BOARD ROOM, 1231 ADDISON STREET**

**ZAB APPEAL: USE PERMIT/VARIANCE #ZP2018-0021**

Notice is hereby given by the City Council of the City of Berkeley that on **TUESDAY, MARCH 26, 2019 at 6:00 P.M.** a public hearing will be conducted to consider an appeal against a decision by the Zoning Adjustments Board's denial of Use Permit/Variance #ZP2018-0021, to legalize an unpermitted detached dwelling unit in the rear yard area of a lot legally developed with an eight-unit apartment building.

A copy of the agenda material for this hearing will be available on the City's website at [www.CityofBerkeley.info](http://www.CityofBerkeley.info) as of **March 14, 2019**.

For further information, please contact Leslie Mendez, Project Planner at (510) 981-7426 Written comments should be mailed or delivered directly to the City Clerk, 2180 Milvia Street, Berkeley, CA 94704, in order to ensure delivery to all Councilmembers and inclusion in the agenda packet.

Communications to the Berkeley City Council are public record and will become part of the City's electronic records, which are accessible through the City's website. **Please note: e-mail addresses, names, addresses, and other contact information are not required, but if included in any communication to the City Council, will become part of the public record.** If you do not want your e-mail address or any other contact information to be made public, you may deliver communications via U.S. Postal Service or in person to the City Clerk. If you do not want your contact information included in the public record, please do not include that information in your communication. Please contact the City Clerk at 981-6900 or [clerk@cityofberkeley.info](mailto:clerk@cityofberkeley.info) for further information.

---

Mark Numainville, City Clerk

Mailed: March 12, 2019

**NOTICE CONCERNING YOUR LEGAL RIGHTS:** *If you object to a decision by the City Council to approve or deny (Code Civ. Proc. §1094.6(b)) or approve (Gov. Code 65009(c)(5)) an appeal, the following requirements and restrictions apply: 1) Pursuant to Code of Civil Procedure Section 1094.6, no lawsuit challenging a City decision to deny or approve a Zoning Adjustments Board decision may be filed more than 90 days after the date the Notice of Decision of the action of the City Council is mailed. Any lawsuit not filed within that 90-day period will be barred. 2) In any lawsuit that may be filed against a City Council decision to approve or deny a Zoning Adjustments Board decision, the issues and evidence will be limited to those raised by you or someone else, orally or in writing, at a public hearing or prior to the close of the last public hearing on the project.*

*If you challenge the above in court, you may be limited to raising only those issues you or someone else raised at the public hearing described in this notice, or in written correspondence delivered to the City of Berkeley at, or prior to, the public hearing. Background information concerning this proposal will be available at the City Clerk Department and posted on the City of Berkeley webpage at least 10 days prior to the public hearing.*







Lori Droste  
Councilmember, District 8

## REVISED AGENDA MATERIAL for Supplemental Packet 2

**Meeting Date:** March 26, 2019 (continued from February 26, 2019)

**Item Number:** 22

**Item Description:** Missing Middle Housing Report

**Submitted by:** Councilmember Lori Droste, Councilmember Ben Bartlett, Councilmember Rigel Robinson, and Councilmember Rashi Kesarwani

This item has been revised to include [friendly amendments](#) from Mayor Jesse Arreguín, Councilmember Sophie Hahn and Councilmember Kate Harrison ([in blue underlined](#)) to include best practices research, analysis of hillside neighborhoods, pressures on neighborhoods with historic redlining, considering additional design and green elements, historic preservation, and administrative and public processes. Other considerations by the authors to address affordability and displacement are noted *in red italics*.



Lori Droste  
Councilmember, District 8

## **ACTION CALENDAR**

March 26, 2019

**To:** Honorable Mayor and Members of the City Council

**From:** Councilmember Lori Droste, Councilmember Ben Bartlett, Councilmember Rigel Robinson, and Councilmember Rashi Kesarwani

**Subject:** Missing Middle Housing Report

### **RECOMMENDATION**

Refer to the City Manager to prepare a report to the Council of examining methods, including potential revisions to the zoning code, that may foster a broader range housing types across Berkeley, particularly missing middle housing types (duplexes, triplexes/fourplexes, courtyard apartments, bungalow courts, townhouses, etc.), in areas with access to essential components of livability like parks, schools, employment, transit, and other services.

The report should examine how other cities that have prepared for and implemented these changes particularly Minneapolis, Seattle, Chicago, and Portland, did so, including mitigating potential side effects, particularly on displacement and increases in rental prices in the surrounding area.

The report(s) should include, but is (are) not limited to

1. Identifying where missing middle housing may be optimal
2. Allowing the possibility of existing houses/footprints/zoning envelopes to be divided into up to 4 units, potentially scaling the floor area ratio (FAR) to increase as the number of units increase on site, creating homes that are more affordable,

saving and lightly modifying an older structure as part of internally dividing it into more than one unit<sup>1</sup>

3. Evaluating Berkeley's residential areas –including Berkeley hillsides– while also considering fire and disaster preparedness service needs
4. Considering design elements and form-based zoning, which addresses the appropriate form, scale and massing of buildings as they relate to one another, as a potential strategy<sup>2</sup>
5. Creating incentives to maintain family-friendly housing stock while adding more diversity and range of smaller units
6. Creating incentives for building more than one unit on larger than average lots
7. Providing suggestions to
  - a. protect existing housing stock, particularly affordable and rent-controlled stock
  - b. protect tenant and vulnerable low-income individuals
  - c. control demolition
  - d. ensure no net loss provisions, and
  - e. increase affordability with provisions that align with our land value recapture policy objectives
8. Evaluating whether changes –or lack of changes– would
  - a. place particular economic or gentrifying pressure on low-income neighborhoods with historic redlining or contribute to
  - b. Contribute to further exclusion and/or exacerbate racial and economic segregation in Berkeley.
9. Evaluating methods for promoting first time home ownership of these units (e.g. Open Doors Initiative) and/or providing assistance to first time homebuyers so that the benefits of the additional housing are equitably distributed
10. Incorporating green features and evaluating environmental impacts of missing middle housing
11. Considering historic preservation efforts and preventing impacts to designated historic resources
12. Examining how different cities effectuated these changes (e.g. changes to their General Plan, zoning changes, etc.), and
13. Evaluating the public process used in the course of considering these changes

Given the range of requests included in this referral, it is expected that responding to the referral will require a combination of field research, consultation with design

---

<sup>1</sup> City of Portland, <https://www.portlandoregon.gov/bps/article/711691>.

<sup>2</sup> Form-Based Codes Institute at Smart Growth America, 1152 15th Street NW Ste. 450 Washington, DC 20005. <https://formbasedcodes.org/definition/>

professionals and other cities and agencies, and community outreach and engagement. Council requests that staff initiate this work as soon as possible.

### **CURRENT PROBLEM AND ITS EFFECTS**

The nine-county Bay Area region is facing an extreme shortage of homes that are affordable for working families. The Metropolitan Transportation Commission illustrates the job-housing imbalance in a recently released a report showing that only one home is added for every 3.5 jobs created in the Bay Area region.<sup>3</sup> Governor Gavin Newsom has called for a “Marshall Plan for affordable housing” and has pledged to create millions of more homes in California to tackle the state’s affordability and homelessness crisis.

In Berkeley, the median sale price of a home is \$1.2 million (as of December 2018)—an increase of 65% over the median sale price in December 2013 of \$727,000. Similarly, Berkeley’s median rent index is \$3,663/month—a 54% increase since December 2013.<sup>4</sup> The escalating rents coincided with an increase of 17% in Berkeley’s homeless population as documented in the 2015 and 2017 point-in-time counts.<sup>5</sup> These skyrocketing housing costs put extreme pressure on low-, moderate- and middle-income households, as they are forced to spend an increasing percentage share of their income on housing (leaving less for other necessities like food and medicine), live in overcrowded conditions, or endure super-commutes of 90 minutes or more in order to make ends meet.

#### *Low-Income Households*

Recently, low-income households experienced the greatest increases in rent as a portion of their monthly income. According to the Urban Displacement Project, households are considered to be “rent burdened” when more than a third of their income goes toward housing costs. In Alameda County, “Although rent burden increased across all income groups, it rose most substantially for low- and very low-income households. In both 2000 and 2015, extremely low-income renters were by far the most likely to experience severe rent burden, with nearly three quarters spending more than half their income on rent.”<sup>6</sup>

Although residents of Berkeley recently passed Measure O which will substantially increase funding for affordable housing, low-income units are increasingly expensive to

<sup>3</sup> Metropolitan Transportation Commission, 2018. <http://www.vitalsigns.mtc.ca.gov/>

<sup>4</sup> Berkeley Home Prices and Values, <https://www.zillow.com/berkeley-ca/home-values/>

<sup>5</sup> Berkeley Homeless Point-in-Time Count and Survey Data, 2017. [https://www.cityofberkeley.info/Clerk/City\\_Council/2017/07\\_Jul/Documents/2017-07-25\\_Item\\_53\\_2017\\_Berkeley\\_Homeless.aspx](https://www.cityofberkeley.info/Clerk/City_Council/2017/07_Jul/Documents/2017-07-25_Item_53_2017_Berkeley_Homeless.aspx)

<sup>6</sup> Zuk, M., & Chapple, K. (2015). Urban Displacement Project. [http://www.urbandisplacement.org/sites/default/files/images/alameda\\_final.pdf](http://www.urbandisplacement.org/sites/default/files/images/alameda_final.pdf)

create. Low-income housing units typically cost well over \$500,000 to create and the demand for this type of affordable/subsidized housing exceeds the supply.<sup>7</sup> In Berkeley, roughly 700 seniors applied for the 42 affordable/subsidized units at Harpers Crossings.<sup>8</sup> Without a substantial additional increase in funding for affordable housing, the vast majority of low-income individuals have to rely on the market.

### *Middle-Income Households*

In the Bay Area, those earning middle incomes are facing similar challenges in finding affordable homes. The Pew Research Center classifies middle income households as those with “adults whose annual household income is two-thirds to double the national median.” In 2016, middle income households were those earning approximately \$45,000 to \$136,000 for a household of three.<sup>9</sup> However, in Berkeley, a similarly-sized family earning up to \$80,650 (80% Area Median Income) is considered low-income according to the U.S. Department of Housing and Urban Development.<sup>10</sup>

In the Bay Area, a family currently has to earn \$200,000 annually to afford the principal, interest, taxes and insurance payments on a median-priced home in the Bay Area (assuming they can pay 20 percent of the median home price of nearly \$1,000,000 up front).<sup>11</sup> This means that many City of Berkeley employees couldn’t afford to live where they work: a community health worker (making \$63,600) and a janitor (making \$58,300) wouldn’t be able to afford a home. Neither would a fire captain (making \$142,000) with a stay at home spouse. Even a police officer (making \$122,600) and a groundskeeper (making \$69,300), or two librarians (making \$71,700) couldn’t buy a house.<sup>12</sup>

Berkeley Unified School District employees have recently been advocating for teacher housing. Unfortunately, the housing options for teachers are insufficient for the overwhelming need. According to a recent Berkeley Unified School District (BUSD) survey, 69% of teachers or staff who rent believe that high housing costs will impact

---

<sup>7</sup> “The Cost of Building Housing” *The Turner Center* <https://turnercenter.berkeley.edu/construction-costs-series>

<sup>8</sup> Flood, Lucy. (1/18/2018). “Berkeley low-income seniors get a fresh start at Harper Crossing.” <https://www.berkeleyside.com/2018/01/18/berkeley-low-income-seniors-get-fresh-start-harper-crossing>

<sup>9</sup> Kochhar, Rakesh. “The American middle class is stable in size, but losing ground financially to upper-income families,” 9/16/2018, Pew Research Center. <http://www.pewresearch.org/fact-tank/2018/09/06/the-american-middle-class-is-stable-in-size-but-losing-ground-financially-to-upper-income-families/>

<sup>10</sup> Berkeley Housing Authority, HUD Income Guidelines, effective April 1, 2018. [https://www.cityofberkeley.info/BHA/Home/Payment\\_Standards\\_Income\\_Limits\\_and\\_Utility\\_Allowance.aspx](https://www.cityofberkeley.info/BHA/Home/Payment_Standards_Income_Limits_and_Utility_Allowance.aspx)

<sup>11</sup> “The salary you must earn to buy a home in the 50 largest metros” (10/14/2018). HSH.com <https://www.hsh.com/finance/mortgage/salary-home-buying-25-cities.html#>

<sup>12</sup> City of Berkeley Human Resources, “Job Descriptions” <http://agency.governmentjobs.com/berkeley/default.cfm?action=agencyspecs&agencyID=1568>

their ability to retain their BUSD positions.<sup>13</sup> Since individual K-12 teacher salaries average ~\$75,962,<sup>14</sup> the majority of teachers are not classified as low-income (<\$62,750), according to Housing and Urban Development guidelines. As a result, many cannot qualify for affordable housing units.

Since middle income individuals and families can't qualify for affordable housing units and very few subsidies are available to help, most have to rely on non-governmental subsidized methods and the private market to live in the Bay Area.

### *Families*

Many families are fleeing the Bay Area due to the high cost of living. According to a recently released study by the Turner Center for Housing Innovation, the income and racial patterns out-migration and in-migration indicate that “the region risks backsliding on inclusion and diversity and displacing its economically vulnerable and minority residents to areas of more limited opportunity.”<sup>15</sup> Rent for a two bedroom apartment in Berkeley costs approximately \$3,200/month<sup>16</sup> while the median child care cost in Alameda County is \$1,824 a month, an increase of 36% in the past four years.<sup>17</sup> Consequently, many families are paying well over \$60,000 for living and childcare expenses alone.

### *Homelessness*

High housing costs also lead to California having among the highest rates of poverty in the nation at 19%.<sup>18</sup> Consequently, homelessness is on the rise throughout California. The Bay Area has one of the largest and least-sheltered homeless populations in North America.<sup>19</sup> The proliferation of homeless encampments—from select urban neighborhoods to locations across the region—is the most visible manifestation of the Bay Area's extreme housing affordability crisis. According to the 2017 point-in-time count, Berkeley had approximately 972 individuals experiencing homelessness on any

---

<sup>13</sup> Berkeley Unified School District, “Recommendation for District-Owned Rental Housing for Employees”, <https://documentcloud.adobe.com/link/track?uri=urn%3Aaaid%3Aascds%3AUS%3Adfd74865-9541-4ff8-b6a6-4dcbd30acdc3>

<sup>14</sup> Education Data Partnership, “Teacher Salaries” <http://www.ed-data.org/district/Alameda/Berkeley-Unified>

<sup>15</sup> Romem, Issa and Elizabeth Kneebone, 2018. “Disparity in Departure: Who Leaves the Bay Area and Where Do They Go?” <https://turnercenter.berkeley.edu/disparity-in-departure>

<sup>16</sup> Berkeley Rentals, <https://www.zillow.com/berkeley-ca/home-values/>

<sup>17</sup> D'Souza, Karen, 2/3/19. “You think Bay Area housing is expensive? Child care costs are rising, too.” <https://www.mercurynews.com/2019/02/03/you-think-bay-area-housing-is-expensive-childcare-costs-are-rising-too/amp/>

<sup>18</sup> The U.S. Census The Supplemental Poverty Measure adjusts thresholds based on cost of living indexes.

<sup>19</sup> SPUR: Ideas and Action for a Better City. “Homelessness in the Bay Area: Solving the problem of homelessness is arguably our region's greatest challenge.” Molly Turner, Urbanist Article, October 23, 2017 <https://www.spur.org/publications/urbanist-article/2017-10-23/homelessness-bay-area>

given night.<sup>20</sup> In order to act in accordance with best practices research on alleviating homelessness and help homeless individuals get housed, the City needs to create more homes.<sup>21</sup> Tighter housing markets are associated with higher rates of homelessness, indicating that the creation of additional housing for all income levels is key to mitigating the crisis.<sup>22</sup> In 2015, the non-partisan California’s Legislative Analyst Office published a report addressing the state’s high housing costs. Their report revealed that growth control policies increased home prices by 3-5%.<sup>23</sup> In the 1,000 Person Plan to Address Homelessness, Berkeley’s Health, Housing and Community Services staff also recommend that Council prioritizes “implementing changes to Berkeley’s Land Use, Zoning, Development Review Requirements for new housing with an eye toward alleviating homelessness.”

## BACKGROUND

### Missing Middle

*What is missing middle housing?*

Missing middle housing is a term used to describe:

1. a range of clustered or multi-unit housing types compatible in scale with single family homes<sup>24</sup> and/or
2. housing types naturally affordable to those earning between 80-120% of the area median income.

While this legislation aims to address the former, by definition and design, missing middle housing will always be less expensive than comparable single family homes in the same neighborhood, leading to greater accessibility to those earning median, middle, or lower incomes. Currently, the median price of a single family home in Berkeley is \$1.2 million dollars, which is out of reach for the majority of working people.<sup>25</sup> Approximately half of Berkeley’s housing stock consists of single family units<sup>26</sup>

<sup>20</sup> Berkeley Homeless Point-in-Time Count and Survey Data, 2017.

[https://www.cityofberkeley.info/Clerk/City\\_Council/2017/07\\_Jul/Documents/2017-07-25\\_Item\\_53\\_2017\\_Berkeley\\_Homeless.aspxn](https://www.cityofberkeley.info/Clerk/City_Council/2017/07_Jul/Documents/2017-07-25_Item_53_2017_Berkeley_Homeless.aspxn)

<sup>21</sup> United States Interagency Council on Homelessness “The Evidence behind Approaches that Drive an End to Homelessness” December 2017, [https://www.usich.gov/resources/uploads/asset\\_library/evidence-behind-approaches-that-end-homelessness.pdf](https://www.usich.gov/resources/uploads/asset_library/evidence-behind-approaches-that-end-homelessness.pdf)

<sup>22</sup> *Homeless in America, Homeless in California*. John M. Quigley, Steven Raphael, and Eugene Smolensky. The Review of Economics and Statistics, February 2001, 83(1): 37–51 © 2001 by the President and Fellows of Harvard College and the Massachusetts Institute of Technology. [https://urbanpolicy.berkeley.edu/pdf/grs\\_restat01pb.pdf](https://urbanpolicy.berkeley.edu/pdf/grs_restat01pb.pdf)

<sup>23</sup> California’s High Housing Costs, Causes and Consequences, Legislative Analyst Office, March 17, 2015. <https://lao.ca.gov/reports/2015/finance/housing-costs/housing-costs.pdf>

<sup>24</sup> Parolek, Dan. Opticos Design. <http://missingmiddlehousing.com/>

<sup>25</sup> Berkeley Home Prices and Values, <https://www.zillow.com/berkeley-ca/home-values/>

<sup>26</sup> City of Berkeley 2015 -2023 Housing Element. [https://www.cityofberkeley.info/uploadedFiles/Planning\\_and\\_Development/Level\\_3\\_-\\_Commissions/Commission\\_for\\_Planning/2015-2023%20Berkeley%20Housing%20Element\\_FINAL.pdf](https://www.cityofberkeley.info/uploadedFiles/Planning_and_Development/Level_3_-_Commissions/Commission_for_Planning/2015-2023%20Berkeley%20Housing%20Element_FINAL.pdf)

and more than half of Berkeley's residential land is zoned in ways that preclude most missing middle housing. As a result, today, only wealthy households can afford homes in Berkeley.

**Figure 2-4:**

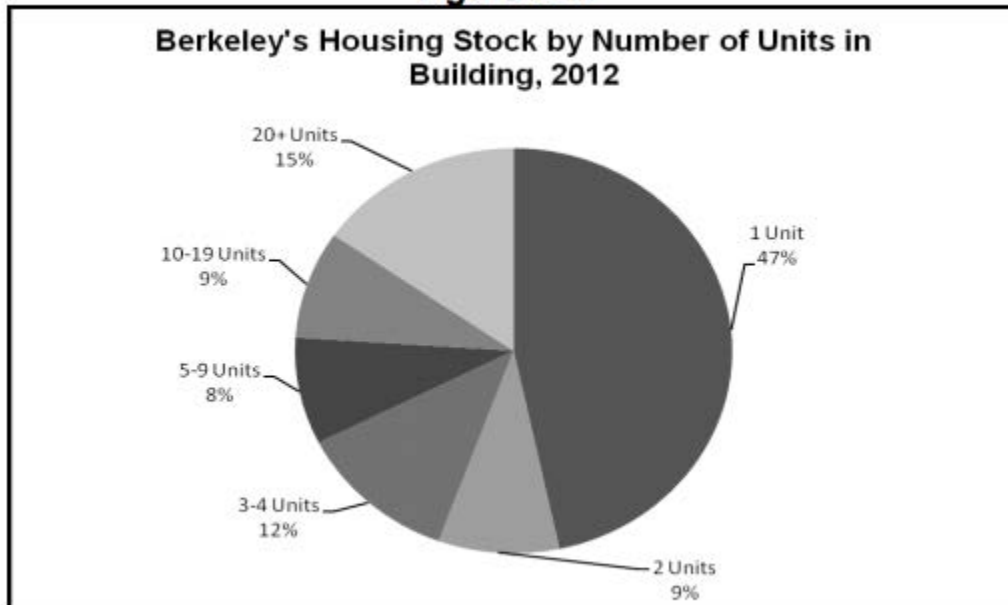

*Source: US Census, ACS 2008-2012 5-Year Estimate., Table B25024*

Missing middle housing includes duplexes, triplexes, courtyard apartments, bungalow courts, and multiplexes that often house people with a variety of incomes. These housing types generally have small- to medium-sized footprints and are often three stories or less, allowing them to blend into the existing neighborhood while still encouraging greater socioeconomic diversity. These types of homes exist in every district of Berkeley, having been built before they were banned in districts only allowing single family homes. Missing middle homes were severely limited in other districts by zoning changes initiated in 1973.

The current housing market has led to “barbell” housing delivery. That is, new units tend to high-priced (market rate or luxury) or highly subsidized (affordable). Consequently, the majority of the population can't access new units because of the dearth of funding, scarcity of land, and high construction costs impose challenges on viability. One study found that individuals trying to create missing middle housing cannot compete financially with larger projects in areas zoned for higher density, noting “many smaller developers have difficulty obtaining the necessary resources (including the competitive funding) required to offset the high initial per-unit development costs, and larger developers with deeper pockets and more experience navigating complex regulatory systems will almost always opt to build projects that are large enough to achieve the



bulk per-unit development rate.”<sup>27</sup> Additionally, many types of missing middle housing are not permitted in areas zoned R1 (single family only), R1A (limited two family), and R2 (restricted two family). Other factors that may prevent the creation of missing middle housing include onerous lot coverage ratios and excessive setback and parking requirements.<sup>28</sup>

### **History of Exclusionary Zoning, Racial and Economic Segregation and Current Zoning**

Prior to the 1970s, a variety of missing middle housing was still being produced and made available to families throughout the Bay Area, particularly in Berkeley. Many triplexes, etc exist in areas now zoned for single family residential (R-1), limited two-family residential (R-1A), and restricted two-family residential (R-2). These areas are now some of the most expensive parts of our city—especially on a per-unit basis.

Until 1984, Martin Luther King Jr Way was known as Grove Street. For decades, Grove Street created a wall of segregation down the center of Berkeley. Asian-Americans and African-Americans could not live east of Grove Street due to race-restrictive covenants that barred them from purchasing or leasing property.<sup>29</sup> While many people are aware of this sordid piece of Berkeley history, less know about Mason-McDuffie Company’s use of zoning laws and racially-restrictive property deeds and covenants to prevent people of color from living in east Berkeley.

Mason-McDuffie race-restrictive covenants state: “if prior to the first day of January 1930 any person of African or Mongolian descent shall be allowed to purchase or lease said property or any part thereof, then this conveyance shall be and become void...”<sup>30</sup> In 1916, McDuffie began lobbying for the exclusionary zoning ordinances in Berkeley to protect against the “disastrous effects of uncontrolled development”<sup>31</sup> and restrict Chinese laundromats and African American dance halls, particularly in the Elmwood and Claremont neighborhoods.<sup>32</sup>

After *Buchanan v Wareley* in 1917, explicit racially restrictive zoning became illegal. However, consideration to maintaining the character of districts became paramount and Mason-McDuffie contracts still stipulated that property owners must be white.

---

<sup>27</sup> The Montgomery Planning Dept., “The Missing Middle Housing Study,” September 2018. [http://montgomeryplanning.org/wp-content/uploads/2018/09/MissingMiddleHousingStudy\\_9-2018.pdf](http://montgomeryplanning.org/wp-content/uploads/2018/09/MissingMiddleHousingStudy_9-2018.pdf)

<sup>28</sup> Ibid.

<sup>29</sup> Wollenberg, *Berkeley, A City in History*, 2008.

<sup>30</sup> Claremont Park Company Indenture, 1910

<sup>31</sup> Lory, Maya Tulip. “A History of Racial Segregation, 1878–1960.” *The Concord Review*, 2013. <http://www.schoolinfosystem.org/pdf/2014/06/04SegregationinCA24-2.pdf>

<sup>32</sup> Weiss, M. A. (1986). Urban Land Developers and the Origins of Zoning Laws: The Case of Berkeley. *Berkeley Planning Journal*, 3(1). Retrieved from <https://escholarship.org/uc/item/26b8d8zh>

In 1933, the federal government created a Home Owners Loan Corporation (HOLC), which produced residential maps of neighborhoods to identify mortgage lending risks for real estate agents, lenders, etc. These maps were based on racial composition, quality of housing stock, access to amenities, etc. and were color coded to identify best (green), still desirable (blue), definitely declining (yellow), and hazardous (red) neighborhoods. These maps enabled discriminatory lending practices (later called 'redlining') and allowed lenders to enforce local segregation standards.<sup>33</sup>



---

<sup>33</sup> NCRC Opening Doors to Economic Opportunity, "HOLC "REDLINING" MAPS: The persistent structure of segregation and economic inequality." Bruce Mitchell and Juan Franco. [https://ncrc.org/wp-content/uploads/dlm\\_uploads/2018/02/NCRC-Research-HOLC-10.pdf](https://ncrc.org/wp-content/uploads/dlm_uploads/2018/02/NCRC-Research-HOLC-10.pdf)

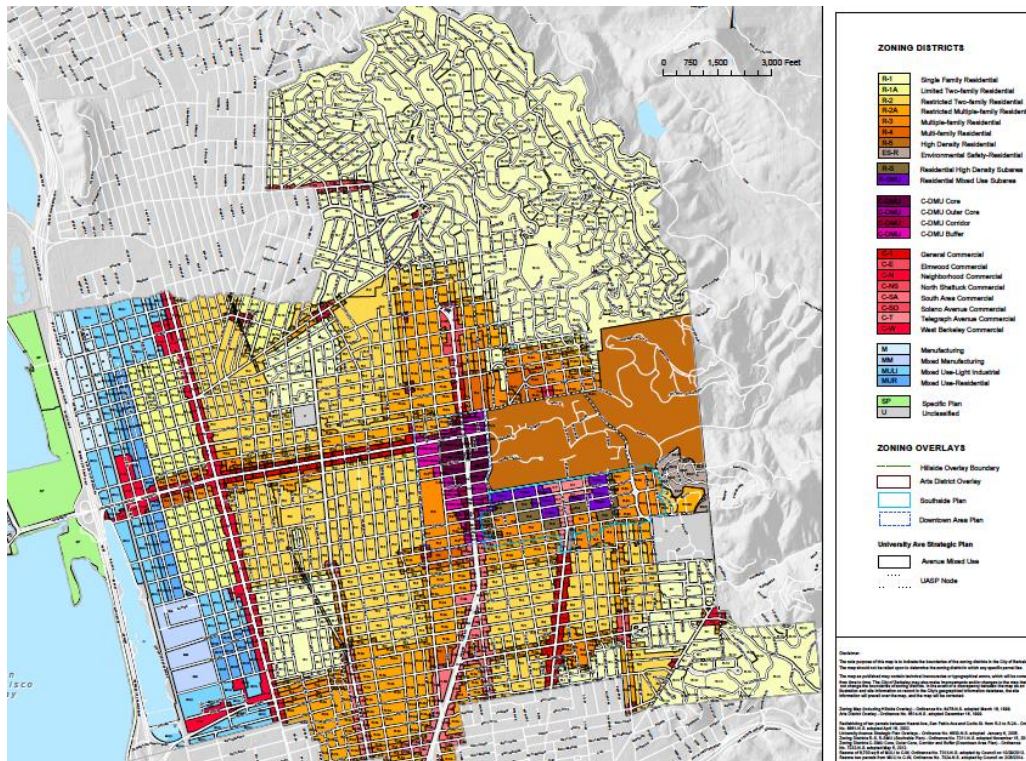

The images above compare a HOLC-era (Thomas Bros Map) map of Berkeley with a current zoning map. Neighborhoods identified as “best” in green on the HOLC-era map typically remain zoned as single family residential areas today. Red ‘hazardous’ neighborhoods in the first map are now largely zoned as manufacturing, mixed use, light industrial, or limited two family residential.<sup>34</sup>

Most cities still retain the vestiges of exclusionary zoning practices. By restricting desirable areas to single-family homes (and banning less expensive housing options, such as duplexes, tri-/four-plexes, courtyard apartments, bungalow courts, and townhouses), the current zoning map dictates that only wealthier families will be able to live or rent in Berkeley. Today, with the median sale price at \$1.2 million, this de-facto form of segregation is even more pronounced.

According to the data mapped by the Urban Displacement Project, most of the low-income tracts in Berkeley are at-risk or have ongoing displacement and gentrification. Higher-income tracts in Berkeley are classified as ‘at-risk of exclusion’, currently feature ‘ongoing exclusion’, or are at stages of ‘advanced exclusion’. Degrees of exclusion are measured by a combination of data: the loss of low-income households over time, presence of high income households, being considered in a ‘hot housing market,’ and migration patterns. The Urban Displacement Project’s findings indicate that exclusion is more prevalent than gentrification in the Bay Area.<sup>35</sup> While Berkeley has created

<sup>34</sup> Robert K. Nelson, LaDale Winling, Richard Marciano, Nathan Connolly, et al., “Mapping Inequality,” American Panorama, ed. Robert K. Nelson and Edward L. Ayers,

<https://dsl.richmond.edu/panorama/redlining/#loc=10/37.8201/-122.4399&opacity=0.8&sort=17&city=oakland-ca&adview=full>

<sup>35</sup> Zuk, M., & Chapple, K. (2015). Urban Displacement Project. <http://www.urbandisplacement.org/map/sf>

policies and designated funding to prevent gentrification, policies that focus on preventing exclusion have lagged.

University of California-Berkeley Professor Karen Chapple, anti-displacement expert and director of the Urban Displacement Project, stated that “the Urban Displacement Project has established a direct connection between the neighborhood designations by the Home Owners Loan Corporation (HOLC), and 75% of today’s exclusionary areas in the East Bay... Thus, this historic legacy, compounded by Berkeley’s early exclusionary zoning practices, continues to shape housing opportunity and perpetuate inequities today.”<sup>36</sup>

### **Historic Redlining**

Redlining was a practice (still mirrored today, in some respects) whereby certain neighborhoods or areas were designated as being high-risk for investment. These high-risk designations were literally marked on maps using red coloring or lines, hence “redlining.” The designations were typically applied to areas with large non-white and/or economically disadvantaged populations, and resulted in people who lived in or wanted to move to these areas being denied loans, or only being provided loans on much worse terms than their counterparts who could access non-redlined areas, due to their ethnicity or higher economic status.

Because redlining practices were contemporaneous with segregationist race-restricted deeds that largely locked minorities out of non-redlined neighborhoods, most non-white households were effectively forced to live in areas where buying and/or improving residential property was extremely difficult. Consequently, low-income and minority families were locked out of homeownership, and all the opportunities for stability and wealth-building that entails. Therefore redlining tended to reinforce the economic stagnation of the areas to which it was applied, further depressing property values and leading to disinvestment. Although redlining is no longer formally practiced in the fashion it was historically, its effects continued to be felt in wealth disparities, educational opportunity gaps, and other impacts.

One way in which the practice of redlining continues to be felt is through the continuation of exclusionary zoning. By ensuring that only those wealthy enough to afford a single family home with a relative large plot of land could live in certain areas, exclusionary zoning worked hand in hand with redlining to keep low-income families out of desirable neighborhoods with good schools and better economic opportunity. Cities, including Berkeley, adopted zoning that effectively prohibited multi-family homes in the

---

<sup>36</sup> Karen Chapple’s February 25, 2019 letter to Berkeley City Council in support of this proposal. See Attachments.

same areas that relied on race restrictive deeds to keep out non-whites, meaning that other areas, including redlined areas, were more likely to continue allowing multi-family buildings.

Ironically, because these patterns of multi-family zoning versus exclusionary zoning have persisted, many areas that were historically redlined are now appealing areas for new housing development precisely because they have continued to allow multi-family homes. Any area which sees its potential housing capacity increase will become more appealing for new housing development. When these changes are made in historically redlined areas where lower-income and minority households tend to be more concentrated, it is especially important to ensure those policies do not result in involuntary displacement or the loss of rent-controlled or naturally-affordable housing units.

### **TENANT AND ANTI-DISPLACEMENT STRATEGIES**

The types of zoning modifications that may result from the requested report could significantly increase Berkeley's housing stock with units that are more affordable to low- and middle-income residents. However, staff's report should consider possible side effects and ways that policy can be crafted to prevent and mitigate negative externalities which could affect tenants and low-income homeowners. Steps must be taken to address the possibility that altering, demolishing, remodeling, or moving existing structures doesn't result in the widespread displacement of Berkeley tenants or loss of rent-controlled units. Staff should consider what measures are needed in conjunction with these zoning changes (e.g. strengthening the demolition ordinance, tenant protections or assistance, no net loss requirements or prohibiting owners from applying if housing was occupied by tenants five years preceding the date of application).

### **ALTERNATIVE ACTIONS CONSIDERED**

We considered an urgency ordinance but after consultation with City of Berkeley staff, we are recommending a report on fostering a variety of housing types to inform future policy decisions, as opposed to zoning revisions.

### **IMPLEMENTATION, ADMINISTRATION, AND ENFORCEMENT**

Not applicable as this item requests an analytical report.

### **FINANCIAL IMPLICATIONS**

Costs for consultants to provide a missing middle scan or an in-depth analysis range from \$25,000-\$65,000. Staff should consider adding components of this Council referral to the city's density standard study in order to accelerate the referral response, as long as it doesn't displace or delay the density standard project.

## ENVIRONMENTAL SUSTAINABILITY

Berkeley declared a climate emergency in 2018. Among other concerns, wildfires and sea level rise are constant ecological threats to our community. The City of Berkeley needs to act urgently to address this imminent danger. Last year, climate researchers in Berkeley quantified local and state opportunities to reduce greenhouse gases from a “comprehensive consumption-based perspective.”<sup>37</sup> The most impactful local policy to potentially reduce greenhouse gas consumption by 2030 is urban infill. In short, Berkeley can meaningfully address climate change if we allow the production of more homes near job centers and transit.

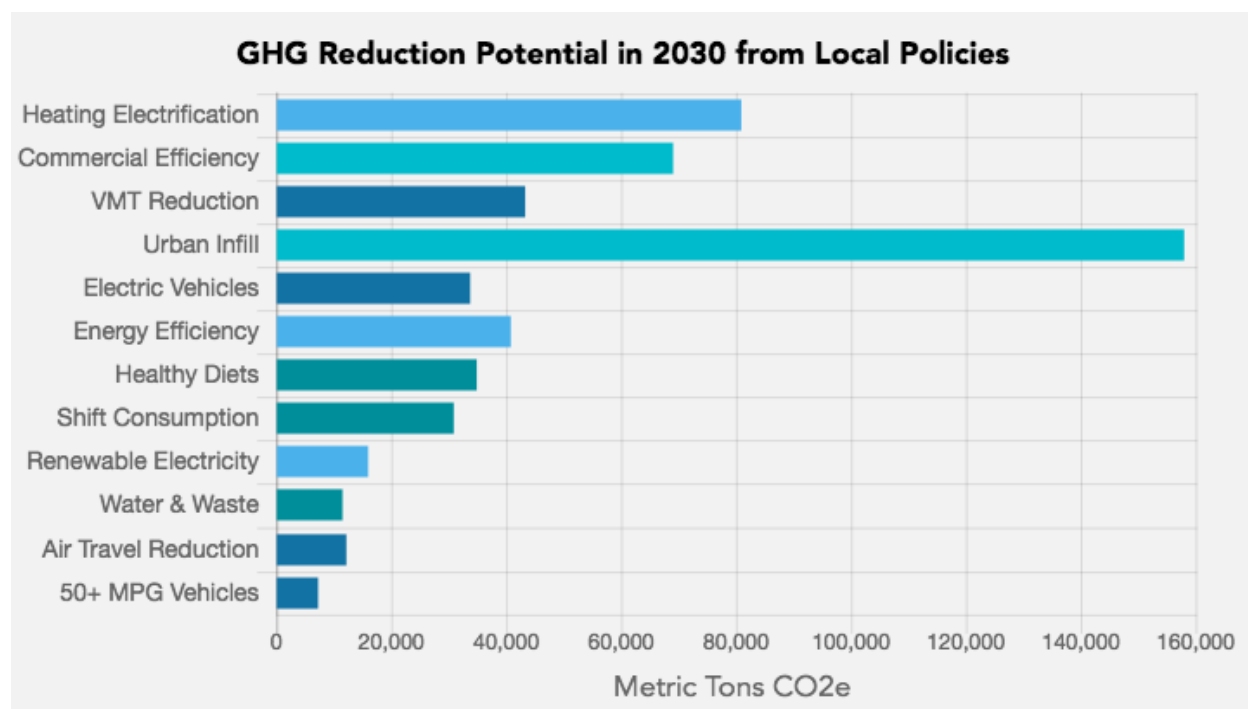

### CONTACT PERSON(S):

Lori Droste, 510-981-7180

### ATTACHMENTS/LINKS:

Minneapolis Plan:

[https://minneapolis2040.com/media/1428/pdf\\_minneapolis2040\\_with\\_appendices.pdf](https://minneapolis2040.com/media/1428/pdf_minneapolis2040_with_appendices.pdf)

<sup>37</sup> “Carbon Footprint Planning: Quantifying Local and State Mitigation Opportunities for 700 California Cities.” Christopher M. Jones, Stephen M. Wheeler, and Daniel M. Kammen. *Urban Planning* (ISSN: 2183–7635) 2018, Volume 3, Issue 2. <https://rael.berkeley.edu/wp-content/uploads/2018/04/Jones-Wheeler-Kammen-700-California-Cities-Carbon-Footprint-2018.pdf>

Seattle' Plan:

<http://www.seattle.gov/Documents/Departments/SeattlePlanningCommission/SPCNeighborhoodsForAllFINAL121318digital.pdf>

## **Berkeleyside**

### **Opinion: We can design our way out of Berkeley's housing crisis with 'missing middle' buildings**

*A Berkeley architect argues that Berkeley should build more small-scale, multi-unit buildings such as duplexes, bungalow courts, fourplexes, and small mansion apartments.*

By Daniel Parolek

Dec. 19, 2017

Berkeley's housing problems have gone national recently, as The New York Times' Conor Dougherty highlighted in a thought-provoking article, "The Great American Single-Family Home Problem." Dougherty examines the conflicting interests and regulations that threatened to halt the development of one lot on Haskell Street, and shows how those conflicting forces are contributing to the affordable housing crisis we are seeing in our state – and across the country.

As an architect and urban designer based in Berkeley for the past 20 years, I agree that California municipalities have an urgent need to deliver more housing. That said, just delivering more housing is not enough. We need to think about how this housing reinforces a high quality built environment and how to provide a range of housing for all segments of the market, including moderate and low-income households. More small-scale, multi-unit buildings such as duplexes, bungalow courts, fourplexes, and small mansion apartments, or what I call "Missing Middle Housing," should be a key focus of that housing.

Unfortunately, the design proposed for the Haskell Street site in Berkeley does not deliver on reinforcing a high quality built environment or affordability and, as the NYT article makes clear, does not deliver on any level of affordability. There are better design solutions that deliver a more compatible form, that have more and a broader range of housing units, and that can be more effective at building local support for this and similar infill projects.

For example, the 50' x 150' lot at 310 Haskell Street is big enough to accommodate a traditional fourplex, with two units down and two units above in a building that is the scale of a house (see image attached from our Missing Middle research). The units would typically be between 750-900 square feet each. An important characteristic of this housing type is that they do not go deeper onto the lot than a traditional house, thus eliminating the concern about privacy and shading and providing high-quality outdoor living spaces. These fourplex housing types exist all over Berkeley and are often successfully integrated onto blocks with single-family homes.

So how do we get there? Berkeley and most cities across the country need to sharpen their pencils on their outdated zoning codes, first to remove barriers for better solutions and secondly, to create a set of regulations that ensure that inappropriate design solutions like the one proposed for Haskell Street or even worse are not allowed on these sites. Lower densities do not equal better design solutions and higher densities do not need to mean larger or more buildings. This is a delicate balance that few zoning codes achieve and few code writers fully



understand.

We also need to change the way we communicate about housing needs in our communities. If we are using George Lakoff's rules for effective communication we would never go into a housing conversation with a community and use terms like "increasing density, adding multi-family, or upzoning a neighborhood." I can think of few neighborhoods that would feel good about saying yes to any of those options if they were framed in that way, but which can mostly get on board with thinking about aging within a neighborhood, or ensuring their kids or grandkids can afford to move back to the city they grew up in. Beginning this conversation by simply showing photographic and/or local existing documented examples of good Missing Middle housing types often disarms this conversation and leads to more fruitful results.

Berkeley's challenges related to housing are not going to go away anytime soon. We need to thoughtfully remove barriers to enable a broad range of solutions like the fourplex that have been a core part of choices provided in our communities already and learn how to effectively build consensus and support for good design solutions such as Missing Middle housing types.

*Daniel Parolek is an architect and urban designer who co-authored the book "Form-Based Codes," coined the term Missing Middle Housing ([www.missingmiddlehousing.com](http://www.missingmiddlehousing.com)) and speaks and consults nationally on these topics.*



February 25, 2019

Honorable Mayor and City Council members:

I am writing to convey my strong support for the "Missing Middle Report" on your 2/26 Council meeting.

As the Council item co-authored by Councilmembers Droste, Bartlett, Kesarwani, and Robinson points out, Berkeley's housing crisis today is a legacy of its past racist and exclusionary practices. I commend their effort to push Berkeley to confront its history in order to build a more inclusive future.

Our research at the Urban Displacement Project has established a direct connection between the neighborhood designations by the Home Owners Loan Corporation (HOLC) and today's patterns of residential displacement and exclusion.<sup>1</sup> Overall, 83% of today's gentrifying areas in the East Bay were rated as "hazardous" (red) or "definitely declining" (yellow) by the HOLC, and 75% of today's exclusionary areas in the East Bay were rated as "best" (green) or "still desirable" (blue) by HOLC. Thus, this historic legacy, compounded by Berkeley's early exclusionary zoning practices, continues to shape housing opportunity and perpetuate inequities today.

Should Berkeley elect to proceed to study the potential for zoning reform, it will be in good company. As the item authors note, Minneapolis and Seattle are already experimenting with ways to open up single-family zones, and Berkeley should be leading the charge as well.<sup>2</sup> Zoning reform has the potential not just to address the housing crisis but also to become a form of restorative or even transformative justice. There is no more important issue for planners to tackle today.

I urge you to vote yes on Item 22 to request a Missing Middle report. Please do not hesitate to call on me if any research on zoning impacts or alternatives is needed.

Sincerely,

Karen Chapple  
Professor, City and Regional Planning  
Carmel P. Friesen Chair in Urban Studies  
Faculty Director, The Urban Displacement Project

<sup>1</sup> See <http://www.urbandisplacement.org/redlining>

<sup>2</sup> Interestingly, leading the charge in Minneapolis is City Council President Lisa Bender, a graduate of UC-Berkeley's Department of City and Regional Planning.



Lori Droste  
Councilmember, District 8

## **ACTION CALENDAR**

March 26, 2019

**To:** Honorable Mayor and Members of the City Council

**From:** Councilmember Lori Droste, Councilmember Ben Bartlett, Councilmember Rigel Robinson, and Councilmember Rashi Kesarwani

**Subject:** Missing Middle *Housing* Report

### **RECOMMENDATION**

Refer to the City Manager to ~~bring back to Council~~ prepare a report to the Council of examining methods, including potential revisions to the zoning code, ~~to~~ that may foster a broader range of housing types across Berkeley, particularly missing middle housing types (duplexes, triplexes/fourplexes, courtyard apartments, bungalow courts, townhouses, etc.), in areas with access to essential components of livability like parks, schools, employment, transit, and other services.

The report should examine how other cities that have prepared for and implemented these changes particularly Minneapolis, Seattle, Chicago, and Portland, did so, including mitigating potential side effects, particularly on displacement and increases in rental prices in the surrounding area and providing assistance to first time homebuyers so that the benefits of the additional housing are equitably distributed.

The report(s) should include, but is (are) not limited to, examining how other cities approached and recommending alternatives to:

1. Identifying where missing middle housing is *may be* optimal/could be permitted and the increase in density
2. Allowing the possibility of existing houses/footprints/zoning envelopes to be divided into up to 4 units, potentially scaling the floor area ratio (FAR) to increase as the number of units increase on site, creating homes that are more affordable,

saving and lightly modifying an older structure as part of internally dividing it into more than one unit<sup>38</sup>

3. ~~Excluding very high fire severity zones as defined by Cal Fire and/or City of Berkeley. *Evaluating Berkeley's residential areas –including Berkeley hillsides– while also unique geological features, such as hillsides and high fire severity zones, and considering fire and disaster preparedness service needs*~~
4. Considering design elements *and* form-based zoning, which addresses the appropriate form, scale and massing of buildings as they relate to one another, as a potential strategy<sup>39</sup>
5. Creating incentives to maintain family-friendly housing stock while adding more diversity and range of smaller units
6. Creating incentives for building more than one unit on larger than average lots
7. Providing suggestions to
  - a. protect existing housing stock, *particularly affordable and rent-controlled stock*
  - b. ~~*protect*~~ provide for Considering provision of tenant and vulnerable low-income *individuals* homeowner protections,
  - c. *control* demolition controls, and
  - d. *ensure* no net loss provisions, and
  - e. increase affordability *with* provisions that align with our land value recapture policy objectives ~~to maximize affordability in Berkeley.~~
8. Evaluating whether changes –or lack of changes– would
  - a. place particular *economic or gentrifying* pressure on low-income neighborhoods with historic redlining
  - b. *Contribute to further exclusion and/or exacerbate racial and economic segregation in Berkeley.*
9. Evaluating methods for promoting first time home ownership of these units (e.g. *Open Doors Initiative*) and/or providing assistance to first time homebuyers so that the benefits of the additional housing are equitably distributed
10. Incorporating green features *and evaluating environmental impacts of missing middle housing*
11. *Considering historic preservation efforts and preventing impacts to designated historic resources*
12. Examining how different cities effectuated these changes (e.g. changes to their General Plan, zoning changes, etc.), *and*
13. Evaluating the public process used in the course of considering these changes

<sup>38</sup> City of Portland, <https://www.portlandoregon.gov/bps/article/711691>.

<sup>39</sup> Form-Based Codes Institute at Smart Growth America, 1152 15th Street NW Ste. 450 Washington, DC 20005. <https://formbasedcodes.org/definition/>

*Given the range of requests included in this referral, it is expected that responding to the referral will require a combination of field research, consultation with design professionals and other cities and agencies, and community outreach and engagement. Council requests that staff initiate this work as soon as possible.*

### **CURRENT PROBLEM AND ITS EFFECTS**

The nine-county Bay Area region is facing an extreme shortage of homes that are affordable for working families. The Metropolitan Transportation Commission illustrates the job-housing imbalance in a recently released a report showing that only one home is added for every 3.5 jobs created in the Bay Area region.<sup>40</sup> Governor Gavin Newsom has called for a “Marshall Plan for affordable housing” and has pledged to create millions of more homes in California to tackle the state’s affordability and homelessness crisis.

In Berkeley, the median sale price of a home is \$1.2 million (as of December 2018)—an increase of 65% over the median sale price in December 2013 of \$727,000. Similarly, Berkeley’s median rent index is \$3,663/month—a 54% increase since December 2013.<sup>41</sup> The escalating rents coincided with an increase of 17% in Berkeley’s homeless population as documented in the 2015 and 2017 point-in-time counts.<sup>42</sup> These skyrocketing housing costs put extreme pressure on low-, moderate- and middle-income households, as they are forced to spend an increasing percentage share of their income on housing (leaving less for other necessities like food and medicine), live in overcrowded conditions, or endure super-commutes of 90 minutes or more in order to make ends meet.

#### *Low-Income Households*

Recently, low-income households experienced the greatest increases in rent as a portion of their monthly income. According to the Urban Displacement Project, households are considered to be “rent burdened” when more than a third of their income goes toward housing costs. In Alameda County, “Although rent burden increased across all income groups, it rose most substantially for low- and very low-income households. In both 2000 and 2015, extremely low-income renters were by far the most likely to experience severe rent burden, with nearly three quarters spending more than half their income on rent.”<sup>43</sup>

---

<sup>40</sup> Metropolitan Transportation Commission, 2018. <http://www.vitalsigns.mtc.ca.gov/>

<sup>41</sup> Berkeley Home Prices and Values, <https://www.zillow.com/berkeley-ca/home-values/>

<sup>42</sup> Berkeley Homeless Point-in-Time Count and Survey Data, 2017. [https://www.cityofberkeley.info/Clerk/City\\_Council/2017/07\\_Jul/Documents/2017-07-25\\_Item\\_53\\_2017\\_Berkeley\\_Homeless.aspx](https://www.cityofberkeley.info/Clerk/City_Council/2017/07_Jul/Documents/2017-07-25_Item_53_2017_Berkeley_Homeless.aspx)

<sup>43</sup> Zuk, M., & Chapple, K. (2015). Urban Displacement Project. [http://www.urbandisplacement.org/sites/default/files/images/alameda\\_final.pdf](http://www.urbandisplacement.org/sites/default/files/images/alameda_final.pdf)

Although residents of Berkeley recently passed Measure O which will substantially increase funding for affordable housing, low-income units are increasingly expensive to create. Low-income housing units typically cost well over \$500,000 to create and the demand for this type of affordable/subsidized housing exceeds the supply.<sup>44</sup> In Berkeley, roughly 700 seniors applied for the 42 affordable/subsidized units at Harpers Crossings.<sup>45</sup> Without a substantial additional increase in funding for affordable housing, the vast majority of low-income individuals have to rely on the market.

### *Middle-Income Households*

In the Bay Area, those earning middle incomes are facing similar challenges in finding affordable homes. The Pew Research Center classifies middle income households as those with “adults whose annual household income is two-thirds to double the national median.” In 2016, middle income households were those earning approximately \$45,000 to \$136,000 for a household of three.<sup>46</sup> However, in Berkeley, a similarly-sized family earning up to \$80,650 (80% Area Median Income) is considered low-income according to the U.S. Department of Housing and Urban Development.<sup>47</sup>

In the Bay Area, a family currently has to earn \$200,000 annually to afford the principal, interest, taxes and insurance payments on a median-priced home in the Bay Area (assuming they can pay 20 percent of the median home price of nearly \$1,000,000 up front).<sup>48</sup> This means that many City of Berkeley employees couldn’t afford to live where they work: a community health worker (making \$63,600) and a janitor (making \$58,300) wouldn’t be able to afford a home. Neither would a fire captain (making \$142,000) with a stay at home spouse. Even a police officer (making \$122,600) and a groundskeeper (making \$69,300), or two librarians (making \$71,700) couldn’t buy a house.<sup>49</sup>

*Berkeley Unified School District employees have recently been advocating for teacher housing. Unfortunately, the housing options for teachers are insufficient for the overwhelming need. According to a recent Berkeley Unified School District (BUSD)*

<sup>44</sup> “The Cost of Building Housing” *The Turner Center* <https://turnercenter.berkeley.edu/construction-costs-series>

<sup>45</sup> Flood, Lucy. (1/18/2018). “Berkeley low-income seniors get a fresh start at Harper Crossing.” <https://www.berkeleyside.com/2018/01/18/berkeley-low-income-seniors-get-fresh-start-harper-crossing>

<sup>46</sup> Kochhar, Rakesh. “The American middle class is stable in size, but losing ground financially to upper-income families,” 9/16/2018, Pew Research Center. <http://www.pewresearch.org/fact-tank/2018/09/06/the-american-middle-class-is-stable-in-size-but-losing-ground-financially-to-upper-income-families/>

<sup>47</sup> Berkeley Housing Authority, HUD Income Guidelines, effective April 1, 2018. [https://www.cityofberkeley.info/BHA/Home/Payment\\_Standards\\_Income\\_Limits\\_and\\_Utility\\_Allowance.aspx](https://www.cityofberkeley.info/BHA/Home/Payment_Standards_Income_Limits_and_Utility_Allowance.aspx)

<sup>48</sup> “The salary you must earn to buy a home in the 50 largest metros” (10/14/2018). HSH.com <https://www.hsh.com/finance/mortgage/salary-home-buying-25-cities.html#>

<sup>49</sup> City of Berkeley Human Resources, “Job Descriptions” <http://agency.governmentjobs.com/berkeley/default.cfm?action=agencyspecs&agencyID=1568>

*survey, 69% of teachers or staff who rent believe that high housing costs will impact their ability to retain their BUSD positions.<sup>50</sup> Since individual K-12 teacher salaries average ~\$75,962,<sup>51</sup> the majority of teachers are not classified as low-income (<\$62,750), according to Housing and Urban Development guidelines. As a result, many cannot qualify for affordable housing units.*

*Since middle income individuals and families can't qualify for affordable housing units and very few subsidies are available to help, most have to rely on non-governmental subsidized methods and the private market to live in the Bay Area.*

### *Families*

Many families are fleeing the Bay Area due to the high cost of living. According to a recently released study by the Turner Center for Housing Innovation, the income and racial patterns out-migration and in-migration indicate that “the region risks backsliding on inclusion and diversity and displacing its economically vulnerable and minority residents to areas of more limited opportunity.”<sup>52</sup> Rent for a two bedroom apartment in Berkeley costs approximately \$3,200/month<sup>53</sup> while the median child care cost in Alameda County is \$1,824 a month, an increase of 36% in the past four years.<sup>54</sup> Consequently, many families are paying well over \$60,000 for living and childcare expenses alone.

### *Homelessness*

High housing costs also lead to California having among the highest rates of poverty in the nation at 19%.<sup>55</sup> Consequently, homelessness is on the rise throughout California. The Bay Area has one of the largest and least-sheltered homeless populations in North America.<sup>56</sup> The proliferation of homeless encampments—from select urban neighborhoods to locations across the region—is the most visible manifestation of the Bay Area’s extreme housing affordability crisis. According to the 2017 point-in-time

<sup>50</sup> **Berkeley Unified School District, “Recommendation for District-Owned Rental Housing for Employees”**, <https://documentcloud.adobe.com/link/track?uri=urn%3Aaaid%3Aascds%3AUS%3Adfd74865-9541-4ff8-b6a6-4dcbd30acdc3>

<sup>51</sup> *Education Data Partnership, “Teacher Salaries”* <http://www.ed-data.org/district/Alameda/Berkeley-Unified>

<sup>52</sup> Romem, Issa and Elizabeth Kneebone, 2018. “Disparity in Departure: Who Leaves the Bay Area and Where Do They Go?” <https://turnercenter.berkeley.edu/disparity-in-departure>

<sup>53</sup> Berkeley Rentals, <https://www.zillow.com/berkeley-ca/home-values/>

<sup>54</sup> D'Souza, Karen, 2/3/19. “You think Bay Area housing is expensive? Child care costs are rising, too.” <https://www.mercurynews.com/2019/02/03/you-think-bay-area-housing-is-expensive-childcare-costs-are-rising-too/amp/>

<sup>55</sup> The U.S. Census The Supplemental Poverty Measure adjusts thresholds based on cost of living indexes.

<sup>56</sup> SPUR: Ideas and Action for a Better City. “Homelessness in the Bay Area: Solving the problem of homelessness is arguably our region’s greatest challenge.” Molly Turner, Urbanist Article, October 23, 2017 <https://www.spur.org/publications/urbanist-article/2017-10-23/homelessness-bay-area>

count, Berkeley had approximately 972 individuals experiencing homelessness on any given night.<sup>57</sup> In order to *act in accordance with best practices research on alleviating homelessness and* help homeless individuals get housed, the City needs to create more homes.<sup>58</sup> Tighter housing markets are associated with higher rates of homelessness, indicating that the creation of additional housing for all income levels is key to mitigating the crisis.<sup>59</sup> *In 2015, the non-partisan California's Legislative Analyst Office published a report addressing the state's high housing costs. Their report revealed that growth control policies increased home prices by 3-5%.<sup>60</sup> In the 1,000 Person Plan to Address Homelessness, Berkeley's Health, Housing and Community Services staff also recommend that Council prioritizes "implementing changes to Berkeley's Land Use, Zoning, Development Review Requirements for new housing with an eye toward alleviating homelessness."*

## BACKGROUND

### Missing Middle

*What is missing middle housing?*

Missing middle housing is a term used to describe:

3. a range of clustered or multi-unit housing types compatible in scale with single family homes<sup>61</sup> and/or
4. housing types naturally affordable to those earning between 80-120% of the area median income.

While this legislation aims to address the former, by definition and design, missing middle housing will always be less expensive than comparable single family homes in the same neighborhood, leading to greater accessibility to those earning median, middle, or lower incomes. Currently, the median price of a single family home in Berkeley is \$1.2 million dollars, which is out of reach for the majority of working

<sup>57</sup> Berkeley Homeless Point-in-Time Count and Survey Data, 2017.

[https://www.cityofberkeley.info/Clerk/City\\_Council/2017/07\\_Jul/Documents/2017-07-25\\_Item\\_53\\_2017\\_Berkeley\\_Homeless.aspxn](https://www.cityofberkeley.info/Clerk/City_Council/2017/07_Jul/Documents/2017-07-25_Item_53_2017_Berkeley_Homeless.aspxn)

<sup>58</sup> United States Interagency Council on Homelessness "The Evidence behind Approaches that Drive an End to Homelessness" December 2017, [https://www.usich.gov/resources/uploads/asset\\_library/evidence-behind-approaches-that-end-homelessness.pdf](https://www.usich.gov/resources/uploads/asset_library/evidence-behind-approaches-that-end-homelessness.pdf)

<sup>59</sup> *Homeless in America, Homeless in California*. John M. Quigley, Steven Raphael, and Eugene Smolensky. The Review of Economics and Statistics, February 2001, 83(1): 37–51 © 2001 by the President and Fellows of Harvard College and the Massachusetts Institute of Technology. [https://urbanpolicy.berkeley.edu/pdf/grs\\_restat01pb.pdf](https://urbanpolicy.berkeley.edu/pdf/grs_restat01pb.pdf)

<sup>60</sup> *California's High Housing Costs, Causes and Consequences*, Legislative Analyst Office, March 17, 2015. <https://lao.ca.gov/reports/2015/finance/housing-costs/housing-costs.pdf>

<sup>61</sup> Parolek, Dan. Opticos Design. <http://missingmiddlehousing.com/>



people.<sup>62</sup> Approximately half of Berkeley's housing stock consists of single family units<sup>63</sup> and more than half of Berkeley's residential land is zoned in ways that preclude most missing middle housing. As a result, today, only wealthy households can afford homes in Berkeley.

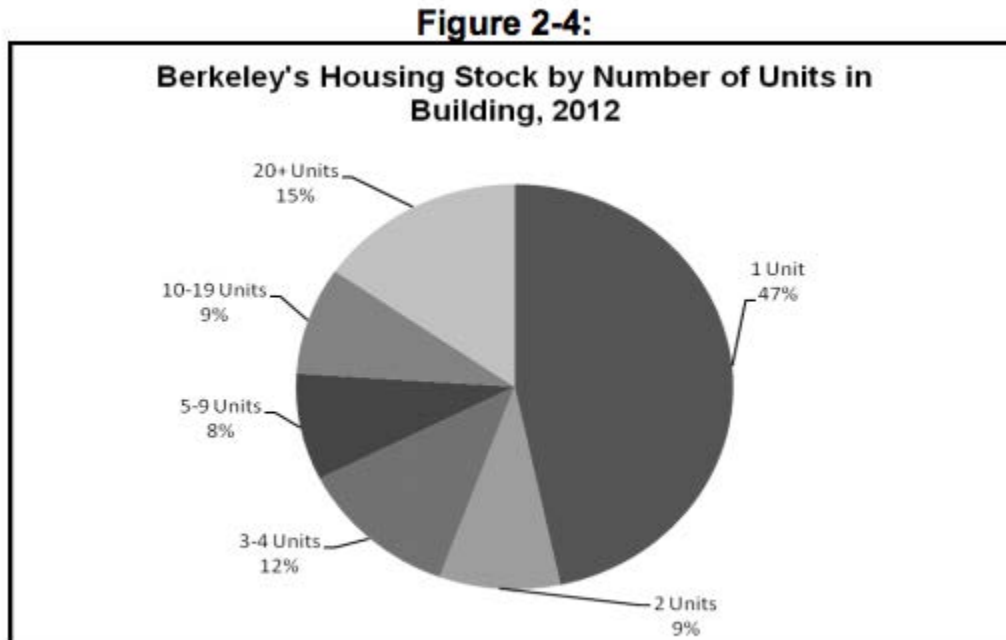

Source: US Census, ACS 2008-2012 5-Year Estimate., Table B25024

Missing middle housing includes duplexes, triplexes, courtyard apartments, bungalow courts, and multiplexes that often house people with a variety of incomes. These housing types generally have small- to medium-sized footprints and are often three stories or less, allowing them to blend into the existing neighborhood while still encouraging greater socioeconomic diversity. These types of homes exist in every district of Berkeley, having been built before they were banned in districts only allowing single family homes. Missing middle homes were severely limited in other districts by zoning changes initiated in 1973.

*The current housing market has led to “barbell” housing delivery. That is, new units tend to high-priced (market rate or luxury) or highly subsidized (affordable). Consequently, the majority of the population can’t access new units because of the dearth of funding, scarcity of land, and high construction costs impose challenges on viability.* One study found that individuals trying to create missing middle housing cannot compete

<sup>62</sup> Berkeley Home Prices and Values, <https://www.zillow.com/berkeley-ca/home-values/>

<sup>63</sup> City of Berkeley 2015 -2023 Housing Element.

[https://www.cityofberkeley.info/uploadedFiles/Planning\\_and\\_Development/Level\\_3\\_-\\_Commissions/Commission\\_for\\_Planning/2015-2023%20Berkeley%20Housing%20Element\\_FINAL.pdf](https://www.cityofberkeley.info/uploadedFiles/Planning_and_Development/Level_3_-_Commissions/Commission_for_Planning/2015-2023%20Berkeley%20Housing%20Element_FINAL.pdf)

financially with larger projects in areas zoned for higher density, noting “many smaller developers have difficulty obtaining the necessary resources (including the competitive funding) required to offset the high initial per-unit development costs, and larger developers with deeper pockets and more experience navigating complex regulatory systems will almost always opt to build projects that are large enough to achieve the bulk per-unit development rate.”<sup>64</sup> Additionally, *many types of* missing middle housing *are* not permitted in areas zoned R1 (single family family only), *R1A (limited two family), and R2 (restricted two family)*. Other factors that may prevent the creation of missing middle housing include onerous lot coverage ratios and excessive setback and parking requirements.<sup>65</sup>

### **History of Exclusionary Zoning, Racial and Economic Segregation and Current Zoning**

Prior to the 1970s, a variety of missing middle housing was still being produced and made available to families throughout the Bay Area, particularly in Berkeley. Many triplexes, etc exist in areas now zoned for single family residential (R-1), limited two-family residential (R-1A), and restricted two-family residential (R-2). These areas are now some of the most expensive parts of our city—especially on a per-unit basis.

Until 1984, Martin Luther King Jr Way was known as Grove Street. For decades, Grove Street created a wall of segregation down the center of Berkeley. Asian-Americans and African-Americans could not live east of Grove Street due to race-restrictive covenants that barred them from purchasing or leasing property.<sup>66</sup> While many people are aware of this sordid piece of Berkeley history, less know about Mason-McDuffie Company’s use of zoning laws and racially-restrictive property deeds and covenants to prevent people of color from living in east Berkeley.

Mason-McDuffie race-restrictive covenants state: “if prior to the first day of January 1930 any person of African or Mongolian descent shall be allowed to purchase or lease said property or any part thereof, then this conveyance shall be and become void...”<sup>67</sup> In 1916, McDuffie began lobbying for the exclusionary zoning ordinances in Berkeley to protect against the “disastrous effects of uncontrolled development”<sup>68</sup> and restrict

---

<sup>64</sup> The Montgomery Planning Dept., “The Missing Middle Housing Study,” September 2018. [http://montgomeryplanning.org/wp-content/uploads/2018/09/MissingMiddleHousingStudy\\_9-2018.pdf](http://montgomeryplanning.org/wp-content/uploads/2018/09/MissingMiddleHousingStudy_9-2018.pdf)

<sup>65</sup> Ibid.

<sup>66</sup> Wollenberg, *Berkeley, A City in History*, 2008.

<sup>67</sup> Claremont Park Company Indenture, 1910

<sup>68</sup> Lory, Maya Tulip. “A History of Racial Segregation, 1878–1960.” *The Concord Review*, 2013. <http://www.schoolinfosystem.org/pdf/2014/06/04SegregationinCA24-2.pdf>

Chinese laundromats and African American dance halls, particularly in the Elmwood and Claremont neighborhoods.<sup>69</sup>

After *Buchanan v Wareley* in 1917, explicit racially restrictive zoning became illegal. However, consideration to maintaining the character of districts became paramount and Mason-McDuffie contracts still stipulated that property owners must be white.

In 1933, the federal government created a Home Owners Loan Corporation (HOLC), which produced residential maps of neighborhoods to identify mortgage lending risks for real estate agents, lenders, etc. These maps were based on racial composition, quality of housing stock, access to amenities, etc. and were color coded to identify best (green), still desirable (blue), definitely declining (yellow), and hazardous (red) neighborhoods. These maps enabled discriminatory lending practices (later called 'redlining') and allowed lenders to enforce local segregation standards.<sup>70</sup>

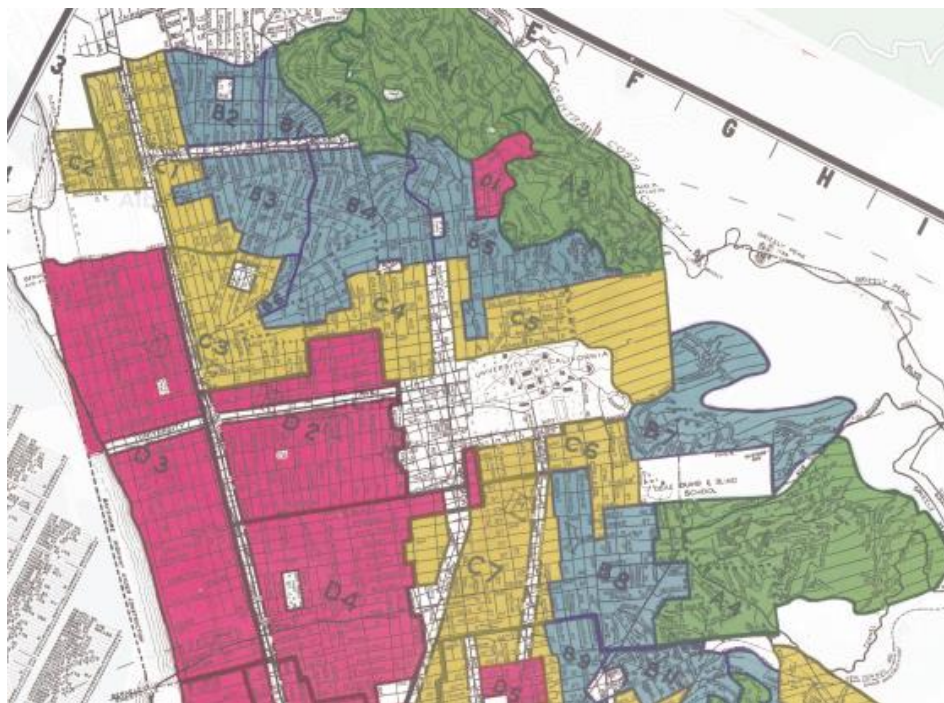

<sup>69</sup> Weiss, M. A. (1986). Urban Land Developers and the Origins of Zoning Laws: The Case of Berkeley. *Berkeley Planning Journal*, 3(1). Retrieved from <https://escholarship.org/uc/item/26b8d8zh>

<sup>70</sup> NCRC Opening Doors to Economic Opportunity, "HOLC "REDLINING" MAPS: The persistent structure of segregation and economic inequality." Bruce Mitchell and Juan Franco. [https://ncrc.org/wp-content/uploads/dlm\\_uploads/2018/02/NCRC-Research-HOLC-10.pdf](https://ncrc.org/wp-content/uploads/dlm_uploads/2018/02/NCRC-Research-HOLC-10.pdf)

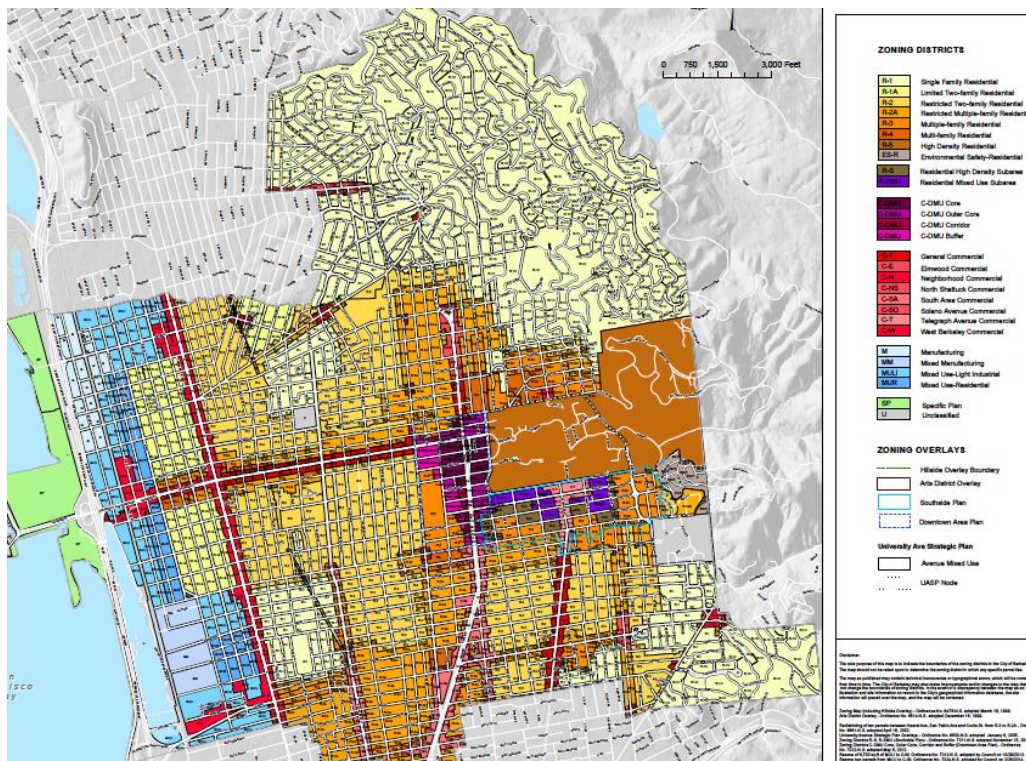

The images above compare a HOLC-era (Thomas Bros Map) map of Berkeley with a current zoning map. Neighborhoods identified as “best” in green on the HOLC-era map typically remain zoned as single family residential areas today. Red ‘hazardous’ neighborhoods in the first map are now largely zoned as manufacturing, mixed use, light industrial, or limited two family residential.<sup>71</sup>

Most cities still retain the vestiges of exclusionary zoning practices. By restricting desirable areas to single-family homes (and banning less expensive housing options, such as duplexes, tri-/four-plexes, courtyard apartments, bungalow courts, and townhouses), the current zoning map dictates that only wealthier families will be able to live or rent in Berkeley. Today, with the median sale price at \$1.2 million, this de-facto form of segregation is even more pronounced.

According to the data mapped by the Urban Displacement Project, most of the low-income tracts in Berkeley are at-risk or have ongoing displacement and gentrification. Higher-income tracts in Berkeley are classified as ‘at-risk of exclusion’, currently feature ‘ongoing exclusion’, or are at stages of ‘advanced exclusion’. Degrees of exclusion are measured by a combination of data: the loss of low-income households over time, presence of high income households, being considered in a ‘hot housing market,’ and migration patterns. The Urban Displacement Project’s findings indicate that exclusion is more prevalent than gentrification in the Bay Area.<sup>72</sup> While Berkeley has created

<sup>71</sup> Robert K. Nelson, LaDale Winling, Richard Marciano, Nathan Connolly, et al., “Mapping Inequality,” American Panorama, ed. Robert K. Nelson and Edward L. Ayers,

<https://dsl.richmond.edu/panorama/redlining/#loc=10/37.8201/-122.4399&opacity=0.8&sort=17&city=oakland-ca&adview=full>

<sup>72</sup> Zuk, M., & Chapple, K. (2015). Urban Displacement Project. <http://www.urbandisplacement.org/map/sf>

policies and designated funding to prevent gentrification, policies that focus on preventing exclusion have lagged.

*University of California-Berkeley Professor Karen Chapple, anti-displacement expert and director of the Urban Displacement Project, stated that “the Urban Displacement Project has established a direct connection between the neighborhood designations by the Home Owners Loan Corporation (HOLC), and 75% of today’s exclusionary areas in the East Bay...Thus, this historic legacy, compounded by Berkeley’s early exclusionary zoning practices, continues to shape housing opportunity and perpetuate inequities today.”<sup>73</sup>*

### **Historic Redlining**

*Redlining was a practice (still mirrored today, in some respects) whereby certain neighborhoods or areas were designated as being high-risk for investment. These high-risk designations were literally marked on maps using red coloring or lines, hence “redlining.” The designations were typically applied to areas with large non-white and/or economically disadvantaged populations, and resulted in people who lived in or wanted to move to these areas being denied loans, or only being provided loans on much worse terms than their counterparts who could access non-redlined areas, due to their ethnicity or higher economic status.*

*Because redlining practices were contemporaneous with segregationist race-restricted deeds that largely locked minorities out of non-redlined neighborhoods, most non-white households were effectively forced to live in areas where buying and/or improving residential property was extremely difficult. Consequently, low-income and minority families were locked out of homeownership, and all the opportunities for stability and wealth-building that entails. Therefore redlining tended to reinforce the economic stagnation of the areas to which it was applied, further depressing property values and leading to disinvestment. Although redlining is no longer formally practiced in the fashion it was historically, its effects continued to be felt in wealth disparities, educational opportunity gaps, and other impacts.*

*One way in which the practice of redlining continues to be felt is through the continuation of exclusionary zoning. By ensuring that only those wealthy enough to afford a single family home with a relative large plot of land could live in certain areas, exclusionary zoning worked hand in hand with redlining to keep low-income families out of desirable neighborhoods with good schools and better economic opportunity. Cities, including Berkeley, adopted zoning that effectively prohibited multi-family homes in the*

---

<sup>73</sup> Karen Chapple’s February 25, 2019 letter to Berkeley City Council in support of this proposal. See Attachments.

*same areas that relied on race restrictive deeds to keep out non-whites, meaning that other areas, including redlined areas, were more likely to continue allowing multi-family buildings.*

*Ironically, because these patterns of multi-family zoning versus exclusionary zoning have persisted, many areas that were historically redlined are now appealing areas for new housing development precisely because they have continued to allow multi-family homes. Any area which sees its potential housing capacity increase will become more appealing for new housing development. When these changes are made in historically redlined areas where lower-income and minority households tend to be more concentrated, it is especially important to ensure those policies do not result in involuntary displacement or the loss of rent-controlled or naturally-affordable housing units.*

## **TENANT AND ANTI-DISPLACEMENT STRATEGIES**

The types of zoning modifications that may result from the requested report could, ~~as discussed above,~~ significantly increase Berkeley's housing stock with units that are more affordable to low- and middle-income residents. However, staff's report should consider possible side effects and ways that policy can be crafted to prevent and mitigate negative externalities which could affect tenants and low-income homeowners. Steps must be taken to address the possibility that altering, demolishing, remodeling, or moving existing structures doesn't result in the widespread displacement of Berkeley tenants or loss of rent-controlled units. Staff should consider what measures are needed in conjunction with these zoning changes (e.g. strengthening the demolition ordinance, tenant protections or assistance, no net loss requirements or prohibiting owners from applying if housing was occupied by tenants five years preceding *the* date of application).

## **ALTERNATIVE ACTIONS CONSIDERED**

We considered an urgency ordinance but after consultation with City of Berkeley staff, we are recommending a report on *fostering a variety of housing types* ~~potential zoning changes~~ to inform future policy decisions, as opposed to ~~immediate~~ zoning revisions.

## **IMPLEMENTATION, ADMINISTRATION, AND ENFORCEMENT**

Not applicable as this item requests an analytical report.

## **FINANCIAL IMPLICATIONS**

~~Staffing or consulting costs to analyze zoning code and produce the report.~~ *Costs for consultants to provide a missing middle scan or an in-depth analysis range from \$25,000-\$65,000. Staff should consider adding components of this Council referral to*

*the city's density standard study in order to accelerate the referral response, as long as it doesn't displace or delay the density standard project.*

## ENVIRONMENTAL SUSTAINABILITY

Berkeley declared a climate emergency in 2018. Among other concerns, wildfires and sea level rise are constant ecological threats to our community. The City of Berkeley needs to act urgently to address this imminent danger. Last year, climate researchers in Berkeley quantified local and state opportunities to reduce greenhouse gases from a “comprehensive consumption-based perspective.”<sup>74</sup> The most impactful local policy to potentially reduce greenhouse gas consumption by 2030 is urban infill. In short, Berkeley can meaningfully address climate change if we allow the production of more homes near job centers and transit.

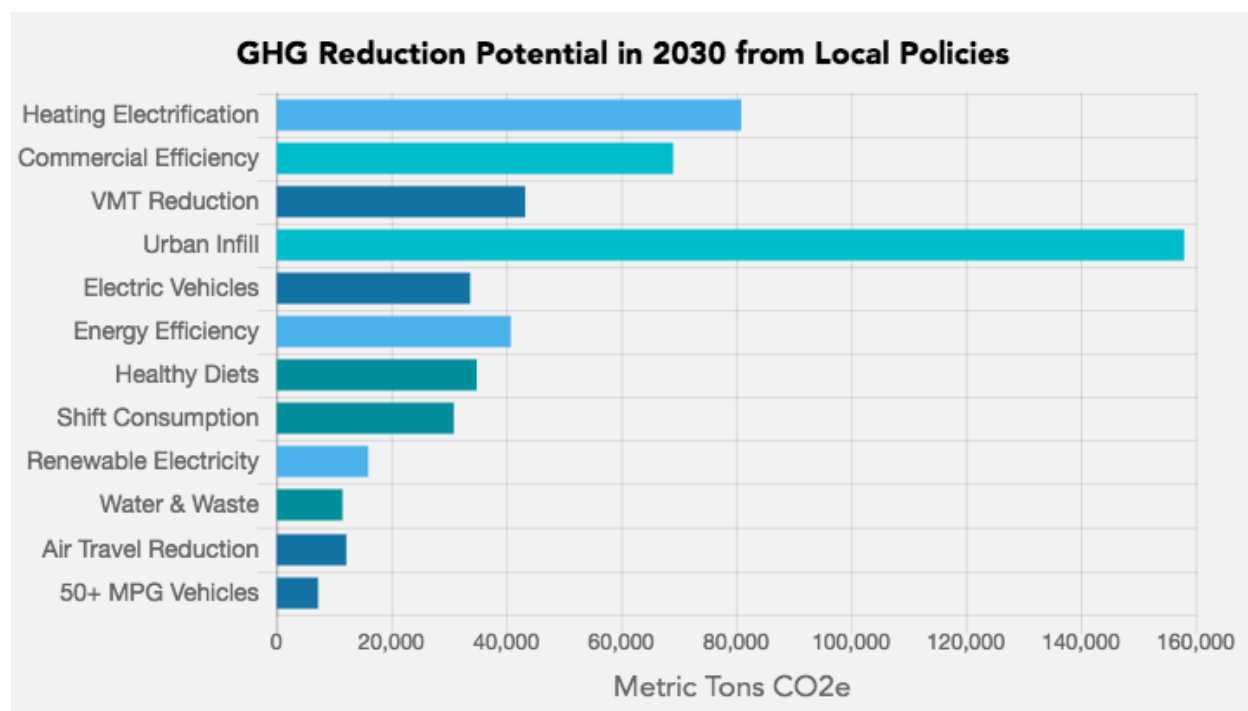

### CONTACT PERSON(S):

Lori Droste, 510-981-7180

### ATTACHMENTS/*LINKS*:

Minneapolis Plan:

<sup>74</sup> “Carbon Footprint Planning: Quantifying Local and State Mitigation Opportunities for 700 California Cities.” Christopher M. Jones, Stephen M. Wheeler, and Daniel M. Kammen. *Urban Planning* (ISSN: 2183–7635) 2018, Volume 3, Issue 2. <https://rael.berkeley.edu/wp-content/uploads/2018/04/Jones-Wheeler-Kammen-700-California-Cities-Carbon-Footprint-2018.pdf>

[https://minneapolis2040.com/media/1428/pdf\\_minneapolis2040\\_with\\_appendices.pdf](https://minneapolis2040.com/media/1428/pdf_minneapolis2040_with_appendices.pdf)

Seattle' Plan:

<http://www.seattle.gov/Documents/Departments/SeattlePlanningCommission/SPCNeighborhoodsForAllFINAL121318digital.pdf>



## **Berkeleyside**

### **Opinion: We can design our way out of Berkeley's housing crisis with 'missing middle' buildings**

*A Berkeley architect argues that Berkeley should build more small-scale, multi-unit buildings such as duplexes, bungalow courts, fourplexes, and small mansion apartments.*

By Daniel Parolek

Dec. 19, 2017

Berkeley's housing problems have gone national recently, as The New York Times' Conor Dougherty highlighted in a thought-provoking article, "The Great American Single-Family Home Problem." Dougherty examines the conflicting interests and regulations that threatened to halt the development of one lot on Haskell Street, and shows how those conflicting forces are contributing to the affordable housing crisis we are seeing in our state – and across the country.

As an architect and urban designer based in Berkeley for the past 20 years, I agree that California municipalities have an urgent need to deliver more housing. That said, just delivering more housing is not enough. We need to think about how this housing reinforces a high quality built environment and how to provide a range of housing for all segments of the market, including moderate and low-income households. More small-scale, multi-unit buildings such as duplexes, bungalow courts, fourplexes, and small mansion apartments, or what I call "Missing Middle Housing," should be a key focus of that housing.

Unfortunately, the design proposed for the Haskell Street site in Berkeley does not deliver on reinforcing a high quality built environment or affordability and, as the NYT article makes clear, does not deliver on any level of affordability. There are better design solutions that deliver a more compatible form, that have more and a broader range of housing units, and that can be more effective at building local support for this and similar infill projects.

For example, the 50' x 150' lot at 310 Haskell Street is big enough to accommodate a traditional fourplex, with two units down and two units above in a building that is the scale of a house (see image attached from our Missing Middle research). The units would typically be between 750-900 square feet each. An important characteristic of this housing type is that they do not go deeper onto the lot than a traditional house, thus eliminating the concern about privacy and shading and providing high-quality outdoor living spaces. These fourplex housing types exist all over Berkeley and are often successfully integrated onto blocks with single-family homes.

So how do we get there? Berkeley and most cities across the country need to sharpen their pencils on their outdated zoning codes, first to remove barriers for better solutions and secondly, to create a set of regulations that ensure that inappropriate design solutions like the one proposed for Haskell Street or even worse are not allowed on these sites. Lower densities do not equal better design solutions and higher densities do not need to mean larger or more buildings. This is a delicate balance that few zoning codes achieve and few code writers fully

understand.

We also need to change the way we communicate about housing needs in our communities. If we are using George Lakoff's rules for effective communication we would never go into a housing conversation with a community and use terms like "increasing density, adding multi-family, or upzoning a neighborhood." I can think of few neighborhoods that would feel good about saying yes to any of those options if they were framed in that way, but which can mostly get on board with thinking about aging within a neighborhood, or ensuring their kids or grandkids can afford to move back to the city they grew up in. Beginning this conversation by simply showing photographic and/or local existing documented examples of good Missing Middle housing types often disarms this conversation and leads to more fruitful results.

Berkeley's challenges related to housing are not going to go away anytime soon. We need to thoughtfully remove barriers to enable a broad range of solutions like the fourplex that have been a core part of choices provided in our communities already and learn how to effectively build consensus and support for good design solutions such as Missing Middle housing types.

*Daniel Parolek is an architect and urban designer who co-authored the book "Form-Based Codes," coined the term Missing Middle Housing ([www.missingmiddlehousing.com](http://www.missingmiddlehousing.com)) and speaks and consults nationally on these topics.*



February 25, 2019

Honorable Mayor and City Council members:

I am writing to convey my strong support for the "Missing Middle Report" on your 2/26 Council meeting.

As the Council item co-authored by Councilmembers Droste, Bartlett, Kesarwani, and Robinson points out, Berkeley's housing crisis today is a legacy of its past racist and exclusionary practices. I commend their effort to push Berkeley to confront its history in order to build a more inclusive future.

Our research at the Urban Displacement Project has established a direct connection between the neighborhood designations by the Home Owners Loan Corporation (HOLC) and today's patterns of residential displacement and exclusion.<sup>1</sup> Overall, 83% of today's gentrifying areas in the East Bay were rated as "hazardous" (red) or "definitely declining" (yellow) by the HOLC, and 75% of today's exclusionary areas in the East Bay were rated as "best" (green) or "still desirable" (blue) by HOLC. Thus, this historic legacy, compounded by Berkeley's early exclusionary zoning practices, continues to shape housing opportunity and perpetuate inequities today.

Should Berkeley elect to proceed to study the potential for zoning reform, it will be in good company. As the item authors note, Minneapolis and Seattle are already experimenting with ways to open up single-family zones, and Berkeley should be leading the charge as well.<sup>2</sup> Zoning reform has the potential not just to address the housing crisis but also to become a form of restorative or even transformative justice. There is no more important issue for planners to tackle today.

I urge you to vote yes on Item 22 to request a Missing Middle report. Please do not hesitate to call on me if any research on zoning impacts or alternatives is needed.

Sincerely,

Karen Chapple  
Professor, City and Regional Planning  
Carmel P. Friesen Chair in Urban Studies  
Faculty Director, The Urban Displacement Project

<sup>1</sup> See <http://www.urbandisplacement.org/redlining>

<sup>2</sup> Interestingly, leading the charge in Minneapolis is City Council President Lisa Bender, a graduate of UC-Berkeley's Department of City and Regional Planning.

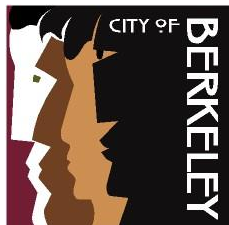

Kate Harrison  
Councilmember District 4

## **REVISED AGENDA MATERIAL for Supplemental Packet 1**

**Meeting Date:**       **March 26, 2019**

**Item Number:**       **22**

**Item Description:**   **Missing Middle Report**

**Submitted by:**       **Councilmembers Kate Harrison and Sophie Hahn and Mayor Jesse Arreguin**

In the report on Missing Middle housing, we ask that the City Manager consider 1) the process by which other cities considered these type of changes and 2) for those that moved forward, how these changes were effectuated. Cities such as Houston, Chicago, Portland, and Minneapolis, among others, have undergone this process in a variety of ways and to varying degrees of success. Berkeley should learn from these cities to guarantee that any Missing Middle housing is built with equity as a key consideration.

The report warrants further examination of how fire impacts our zoning needs. Ingress and egress are critical issues citywide as fire has the potential to spread throughout the City extremely quickly in Berkeley,<sup>1</sup> especially as climate change makes fires stronger and faster. We ask that the report look at how other cities incorporated these concerns and disaster preparedness in all areas of their cities.

No zoning changes should exacerbate gentrification or displacement; it is especially important that the effects of past redlining not be compounded. Automatically excluding all high-fire zones will result in eliminating 70% of the R-1 and R-1A zoning<sup>2</sup> that could be considered for upzoning and result in increased pressure on the areas of the historic redline and in low-income areas. Much of the proposed rezoning aligns with the historic redline; if not done carefully, rezoning can lead to displacement through demolished housing stock and rising rents. San Francisco has recognized that it is losing affordable housing more quickly than it is constructing it. Berkeley is in an affordable housing crisis and must retain the affordable housing we already have.

<sup>1</sup> <https://www.berkeleyside.com/2018/05/21/wildfire-story>

<sup>2</sup> The fire zones make up approximately 50% of the square mileage of all R1, R1-A, and R2 zoned areas.  
2180 Milvia Street, Berkeley, CA 94704   Tel: 510.981.7140   TDD: 510.981.6903  
E-Mail: [kharrison@CityofBerkeley.info](mailto:kharrison@CityofBerkeley.info)

When considering changes to the zoning code, we must also consider the Costa-Hawkins Rental Housing Act's<sup>3</sup> exemption of new units from rent control. Even if current tenants guaranteed a first right to lease at prior rents, these units will lose affordability over time. Existing tenants are likely to leave during the construction period with new tenants facing exorbitant market-rate rental prices. For example, in Chicago,<sup>4</sup> the *particular lots* that were upzoned experienced increases in housing prices and early indications are that no net new housing was produced.<sup>5</sup> Much of the particular lots that were affected in Chicago and would be impacted here are in historically black and brown neighborhoods.

We are also facing a crisis in homeownership. As Councilmember Bartlett examines in his Open Doors Initiative, Berkeley's stock of starter homes is dwindling every year. Missing Middle housing is well-suited for these starter homes, provided that there is sufficient assurance that the housing will be owner-occupied. We ask that the study examine how home ownership rates changed upon implementing Missing Middle in other cities, and whether Berkeley can provide loan or other assistance to guarantee that families are able to own new housing.

### **Recommendation:**

Refer to the City Manager to ~~bring back to~~ prepare a report to the Council ~~a report of examining methods that may~~ foster a broader range of housing types across Berkeley, particularly missing middle housing types (duplexes, triplexes/fourplexes, courtyard apartments, bungalow courts, townhouses, etc.), in areas with access to essential components of livability like parks, schools, employment, transit, and other services. The report should examine how other cities that have prepared for and implemented these changes particularly Minneapolis, Chicago, and Portland, did so including mitigating potential side effects, particularly on displacement and increases in rental prices in the surrounding area and providing assistance to first time homebuyers so that the benefits of the additional housing are equitably distributed.

The rReport should include, but is not limited to, examining how other cities approached and recommending alternatives to:

- Identifying where Missing Middle housing is optimal/~~should could~~ be permitted and the increase in density.
- Allowing the possibility of existing houses/footprints/zoning envelopes to be divided into up to 4 units, potentially scaling the floor area ratio (FAR) to increase as the number of units increase on site, creating programs such that homes ~~that~~ are more affordable, saving and lightly modifying an older structure as part of internally dividing it into more than one unit.
- Excluding very high fire severity zones as defined by the Cal Fire and/or City of Berkeley. Incorporating unique geological features, such as hillsides and high fire severity zones, and considering fire and disaster preparedness service needs.

<sup>3</sup>[https://leginfo.ca.gov/faces/codes\\_displayText.xhtml?lawCode=CIV&division=3.&title=5.&part=4.&chapter=2.7.&article](https://leginfo.ca.gov/faces/codes_displayText.xhtml?lawCode=CIV&division=3.&title=5.&part=4.&chapter=2.7.&article)

<sup>4</sup> <https://www.citylab.com/life/2019/01/zoning-reform-house-costs-urban-development-gentrification/581677/>

<sup>5</sup> "Upzoning Chicago: Impacts of a Zoning Reform on Property Values and Housing Construction", Yonah Freemark, Urban Affairs Review, 2019. Department of Urban Studies and Planning, Massachusetts Institute of Technology, Cambridge, MA.

- Considering form-based zoning as a potential strategy.
- Creating incentives to maintain family-friendly housing stock while adding more diversity and range of smaller units.
- Creating incentives for building more than one unit on larger than average lots.
- Evaluating whether changes would place particular pressure on neighborhoods with historic redlining (see attached PowerPoint); -provide suggestions to protect existing housing stock, provide for tenant protections, demolition controls and; no net loss provisions and increase affordability.
- Considering provisions that align with our land value recapture policy objectives to maximize affordability in Berkeley.
- Evaluating methods for promoting first time home ownership of these units.
- Incorporating design elements, including green features, and impacts on historic preservation.
- Examining how different cities effectuated these changes (e.g., changes to their General Plan, zoning changes, etc.)
- Evaluating the public process used in the course of considering these changes.

## ATTACHMENTS

1: Impacts of Limiting Missing Middle Powerpoint

# Impacts of Limiting Missing Middle

# R-1 and R-1A Zoning in Berkeley

## Untitled map

### Zoning R-1

-  D2 square one
-  D2 Square two
-  D1 square one
-  D1 square two
-  D1 square 3
-  D5 and D6
-  D8 square one
-  D8 two

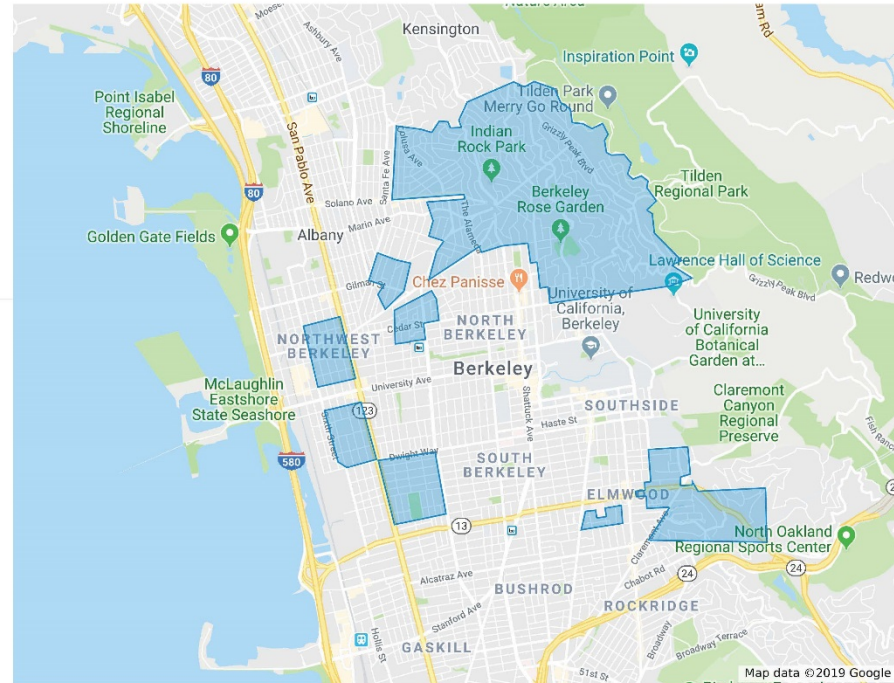



# Adding in R-2

Untitled map

- Zoning R-1
  - D2 square one
  - D2 Square two
  - D1 square one
  - D1 square two
  - D1 square 3
  - D8 square one
  - D8 two
  - D5 and D6
- Zoning R-2
  - D1-5
  - D3 4 and 5
  - D3
  - D7
  - D8 Square 1
  - D8 square 2
  - D8 square 3

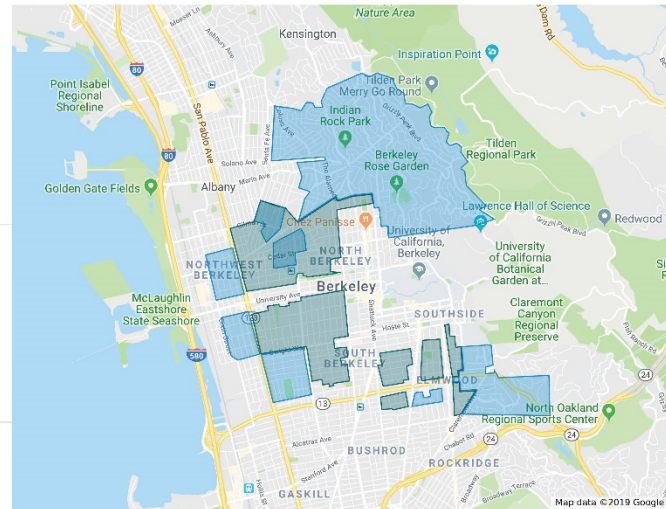

# Historic Redlining

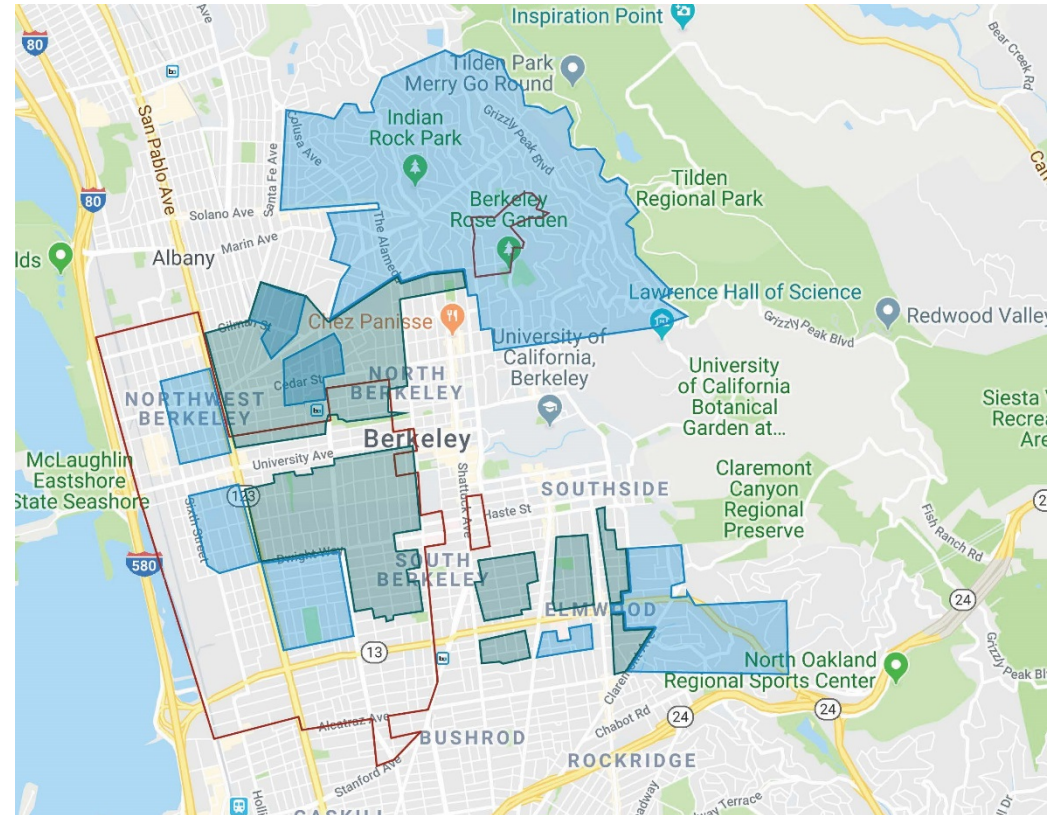
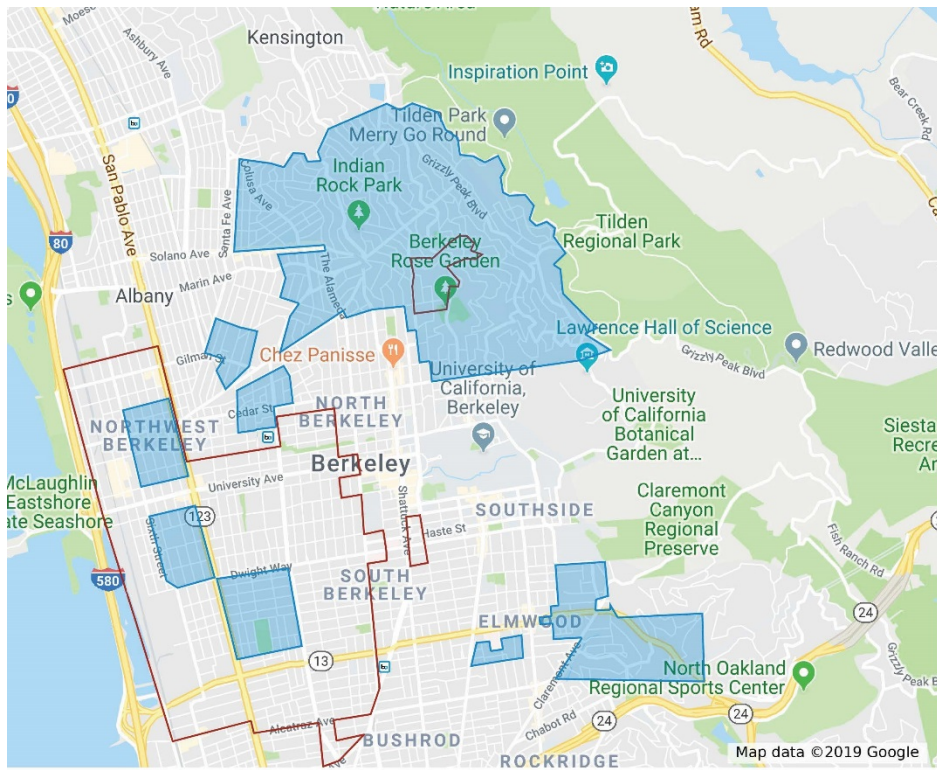

# Fire Zones

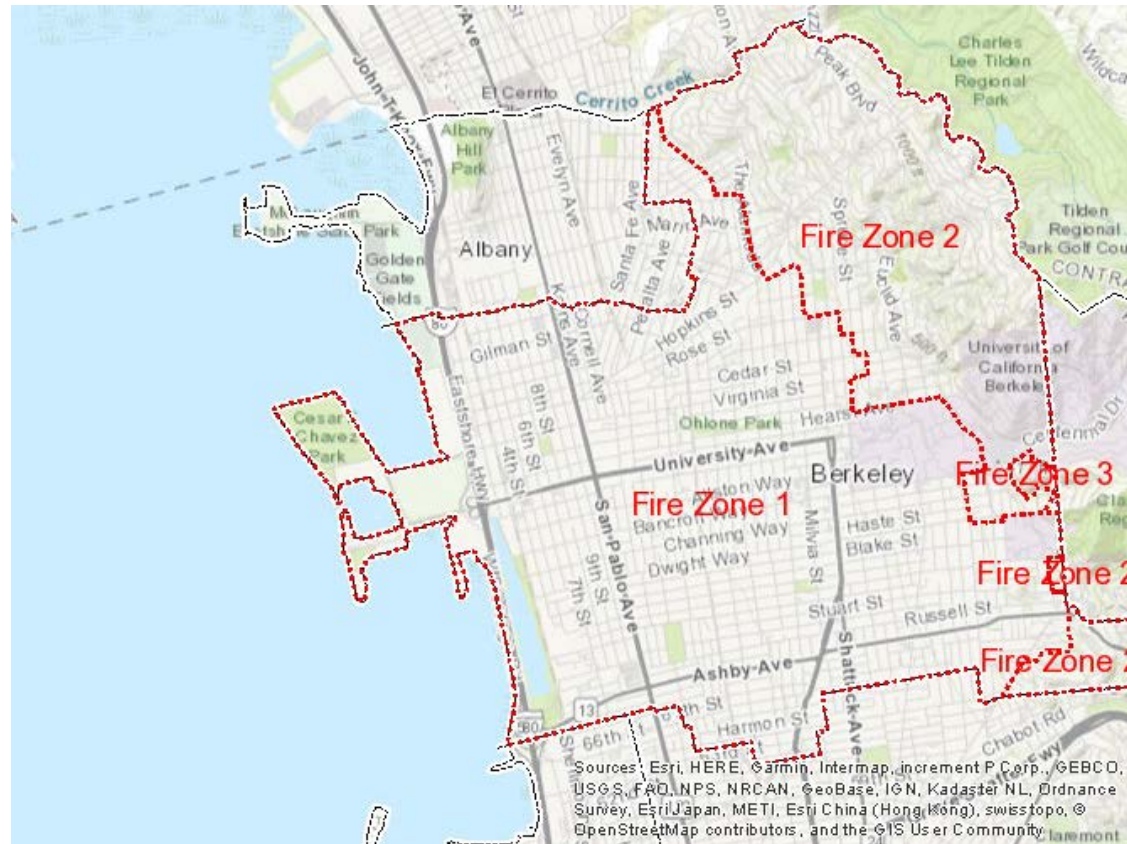

# R1, R1-A, and R2 Excluding Fire Zones

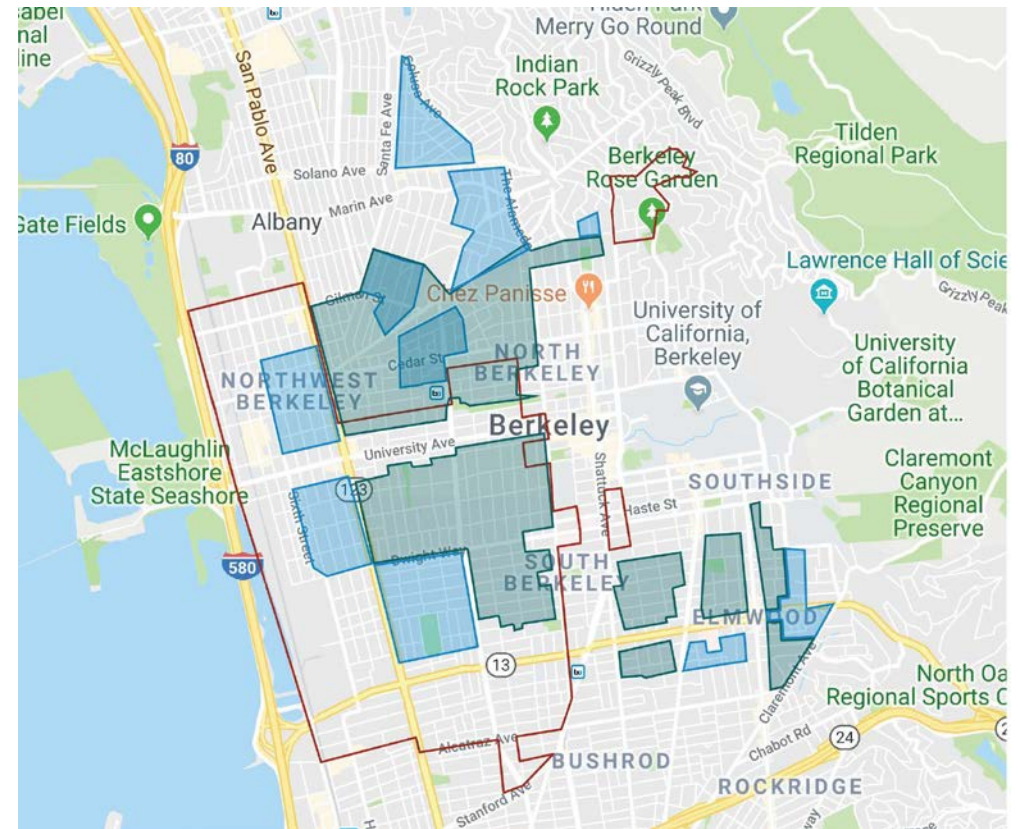
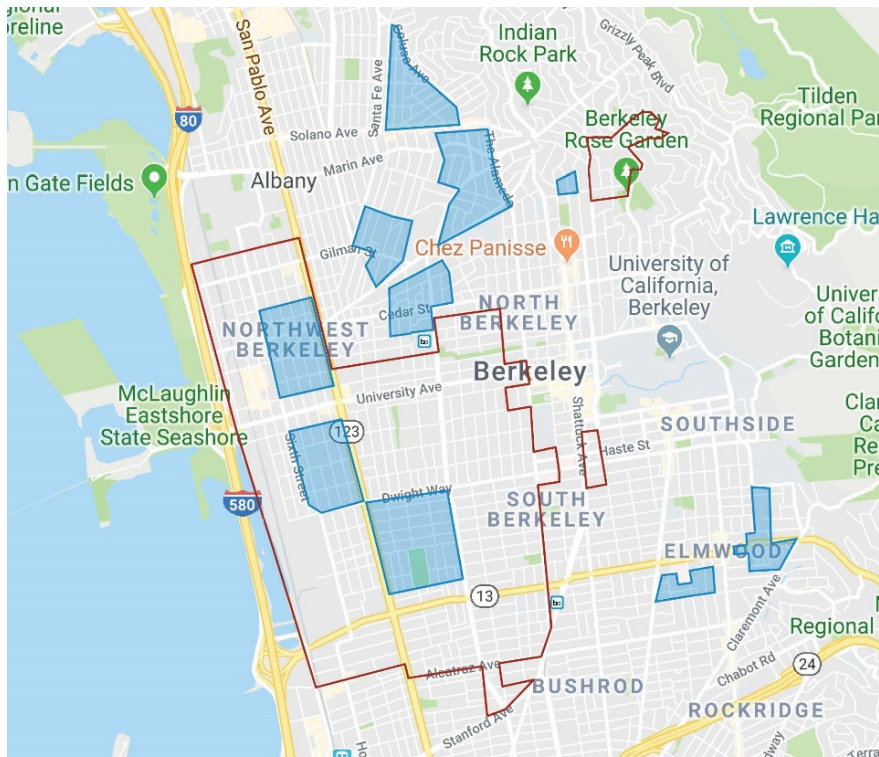

# Why Does Redlining Matter?

- ▶ Potential of rising rents
  - ▶ <https://www.citylab.com/life/2019/01/zoning-reform-house-costs-urban-development-gentrification/581677/>
  - ▶ In Chicago, the particular lots that were upzoned experienced increases in housing prices. Many of the particular lots that would be upzoned in Berkeley are in historic communities of color that already see the effects of gentrification
- ▶ Potential demolition of existing housing stock
  - ▶ Existing stock should not be demolished in a housing crisis
  - ▶ Under Costa-Hawkins, rent-controlled duplexes demolished and replaced with triplexes or fourplexes will be exempt from rent control and lose affordability over time

# Additional Considerations to the Report

- ▶ Incorporating considerations of extreme climate and geological features, such as high fire zones
- ▶ Evaluate how changes may put specific pressures on communities already affected by redlining and discriminatory zoning practices
- ▶ Examine demolition rates in cities that incorporated these changes
- ▶ Examine rent increases or decreases in cities that incorporated these changes
- ▶ Examine home ownership price increases or decreases in cities that incorporated these changes
- ▶ Consider how these changes may affect historic preservation efforts



Lori Droste  
Councilmember, District 8

## **REVISED AGENDA MATERIAL for Supplemental Packet 2**

**Meeting Date:** February 26, 2019

**Item Number:** 21

**Item Description:** **Missing Middle Report**

**Submitted by:** Councilmember Lori Droste, Councilmember Ben Bartlett,  
Councilmember Rigel Robinson, and Councilmember Rashi Kesarwani

This item has been revised to include considerations for scaling of floor to area ratios, land value recapture.



Lori Droste  
Councilmember, District 8

**ACTION CALENDAR**  
February 26, 2019

**To:** Members of the City Council

**From:** Councilmember Lori Droste, Councilmember Ben Bartlett, Councilmember Rigel Robinson, and Councilmember Rashi Kesarwani

**Subject:** Missing Middle Report

**RECOMMENDATION**

Refer to the City Manager to bring back to Council a report of potential revisions to the zoning code to foster a broader range of housing types across Berkeley, particularly missing middle housing types (duplexes, triplexes/fourplexes, courtyard apartments, bungalow courts, townhouses, etc.), in areas with access to essential components of livability like parks, schools, employment, transit, and other services.

Report should include, but is not limited to:

- Identifying where missing middle housing is optimal
- Allowing the possibility of existing houses/footprints/zoning envelopes to be divided into up to 4 units, potentially scaling the floor area ratio (FAR) to increase as the number of units increase on site, creating homes that are more affordable, saving and lightly modifying an older structure as part of internally dividing it into more than one unit.<sup>1</sup>
- Excluding very high fire severity zones as defined by Cal Fire and/or City of Berkeley.

---

<sup>1</sup> City of Portland, <https://www.portlandoregon.gov/bps/article/711691>.



- Considering form-based zoning, which addresses the appropriate form, scale and massing of buildings as they relate to one another, as a potential strategy<sup>2</sup>,
- Creating incentives to maintain family-friendly housing stock while adding more diversity and range of smaller units
- Creating incentives for building more than one unit on larger than average lots,
- Considering provision of tenant and vulnerable low-income homeowner protections, demolition controls, and no net loss provisions
- Considering provisions that align with our land value recapture policy objectives to maximize affordability in Berkeley.

### **CURRENT PROBLEM AND ITS EFFECTS**

The nine-county Bay Area region is facing an extreme shortage of homes that are affordable for working families. The Metropolitan Transportation Commission illustrates the job-housing imbalance in a recently released a report showing that only one home is added for every 3.5 jobs created in the Bay Area region.<sup>3</sup> Governor Gavin Newsom has called for a “Marshall Plan for affordable housing” and has pledged to create millions of more homes in California to tackle the state’s affordability and homelessness crisis.

In Berkeley, the median sale price of a home is \$1.2 million (as of December 2018)—an increase of 65% over the median sale price in December 2013 of \$727,000. Similarly, Berkeley’s median rent index is \$3,663/month—a 54% increase since since December 2013.<sup>4</sup> The escalating rents coincide with an increase of 17% in Berkeley’s homeless population as documented in the 2015 and 2017 point-in-time counts.<sup>5</sup> These skyrocketing housing costs put extreme pressure on low-, moderate- and middle-income households, as they are forced to spend an increasing percentage share of their income on housing (leaving less for other necessities like food and medicine), live in overcrowded conditions, or endure super-commutes of 90 minutes or more in order to make ends meet.

#### *Low-Income Households*

Recently, low-income households experienced the greatest increases in rent as a portion of their monthly income. According to the Urban Displacement Project, households are considered to be “rent burdened” when more than a third of their income goes toward housing costs. In Alameda County, “Although rent burden

---

<sup>2</sup> Form-Based Codes Institute at Smart Growth America, 1152 15th Street NW Ste. 450 Washington, DC 20005. <https://formbasedcodes.org/definition/>

<sup>3</sup> Metropolitan Transportation Commission, 2018. <http://www.vitalsigns.mtc.ca.gov/>

<sup>4</sup> Berkeley Home Prices and Values, <https://www.zillow.com/berkeley-ca/home-values/>

<sup>5</sup> Berkeley Homeless Point-in-Time Count and Survey Data, 2017. [https://www.cityofberkeley.info/Clerk/City\\_Council/2017/07\\_Jul/Documents/2017-07-25\\_Item\\_53\\_2017\\_Berkeley\\_Homeless.aspx](https://www.cityofberkeley.info/Clerk/City_Council/2017/07_Jul/Documents/2017-07-25_Item_53_2017_Berkeley_Homeless.aspx)

increased across all income groups, it rose most substantially for low- and very low-income households. In both 2000 and 2015, extremely low-income renters were by far the most likely to experience severe rent burden, with nearly three quarters spending more than half their income on rent.”<sup>6</sup>

Although residents of Berkeley recently passed Measure O which will substantially increase funding for affordable housing, low-income units are increasingly expensive to create. Low-income housing units typically cost well over \$500,000 to create and the demand for this type of affordable/subsidized housing exceeds the supply.<sup>7</sup> In Berkeley, roughly 700 seniors applied for the 42 affordable/subsidized units at Harpers Crossings.<sup>8</sup> Without a substantial additional increase in funding for affordable housing, the vast majority of low-income individuals have to rely on the market.

### *Middle-Income Households*

In the Bay Area, those earning middle incomes are facing similar challenges in finding affordable homes. The Pew Research Center classifies middle income households as those with “adults whose annual household income is two-thirds to double the national median.” In 2016, middle income households were those earning approximately \$45,000 to \$136,000 for a household of three.<sup>9</sup> However, in Berkeley, a similarly-sized family earning up to \$80,650 (80% Area Median Income) is considered low-income according to the U.S. Department of Housing and Urban Development.<sup>10</sup>

In the Bay Area, a family currently has to earn \$200,000 annually to afford the principal, interest, taxes and insurance payments on a median-priced home in the Bay Area (assuming they can pay 20 percent of the median home price of nearly \$1,000,000 up front).<sup>11</sup> This means that many City of Berkeley employees couldn’t afford to live where they work: a community health worker (making \$63,600) and a janitor (making \$58,300) wouldn’t be able to afford a home. Neither would a fire captain (making \$142,000) with a

<sup>6</sup> Zuk, M., & Chapple, K. (2015). Urban Displacement Project.

[http://www.urbandisplacement.org/sites/default/files/images/alameda\\_final.pdf](http://www.urbandisplacement.org/sites/default/files/images/alameda_final.pdf)

<sup>7</sup> “The Cost of Building Housing” *The Turner Center* <https://turnercenter.berkeley.edu/construction-costs-series>

<sup>8</sup> Flood, Lucy. (1/18/2018). “Berkeley low-income seniors get a fresh start at Harper Crossing.”

<https://www.berkeleyside.com/2018/01/18/berkeley-low-income-seniors-get-fresh-start-harper-crossing>

<sup>9</sup> Kochhar, Rakesh. “The American middle class is stable in size, but losing ground financially to upper-income families,” 9/16/2018, Pew Research Center. <http://www.pewresearch.org/fact-tank/2018/09/06/the-american-middle-class-is-stable-in-size-but-losing-ground-financially-to-upper-income-families/>

<sup>10</sup> Berkeley Housing Authority, HUD Income Guidelines, effective April 1, 2018. [https://www.cityofberkeley.info/BHA/Home/Payment\\_Standards,\\_Income\\_Limits,\\_and\\_Utility\\_Allowance.aspx](https://www.cityofberkeley.info/BHA/Home/Payment_Standards,_Income_Limits,_and_Utility_Allowance.aspx)

<sup>11</sup> “The salary you must earn to buy a home in the 50 largest metros” (10/14/2018). HSH.com <https://www.hsh.com/finance/mortgage/salary-home-buying-25-cities.html#>

stay at home spouse. Even a police officer (making \$122,600) and a groundskeeper (making \$69,300), or two librarians (making \$71,700) couldn't buy a house.<sup>12</sup>

### *Families*

Many families are fleeing the Bay Area due to the high cost of living. According to a recently released study by the Turner Center for Housing Innovation, the income and racial patterns out-migration and in-migration indicate that “the region risks backsliding on inclusion and diversity and displacing its economically vulnerable and minority residents to areas of more limited opportunity.”<sup>13</sup> Rent for a two bedroom apartment in Berkeley costs approximately \$3,200/month<sup>14</sup> while the median child care cost in Alameda County is \$1,824 a month, an increase of 36% in the past four years.<sup>15</sup> Consequently, many families are paying well over \$60,000 for living and childcare expenses alone.

### *Homelessness*

High housing costs also lead to California having among the highest rates of poverty in the nation at 19%.<sup>16</sup> Consequently, homelessness is on the rise throughout California. The Bay Area has one of the largest and least-sheltered homeless populations in North America.<sup>17</sup> The proliferation of homeless encampments—from select urban neighborhoods to locations across the region—is the most visible manifestation of the Bay Area's extreme housing affordability crisis. According to the 2017 point-in-time count, Berkeley had approximately 972 individuals experiencing homelessness on any given night.<sup>18</sup> In order to help homeless individuals get housed, the City needs to create more homes. Tighter housing markets are associated with higher rates of homelessness, indicating that the creation of additional housing for all income levels is key to mitigating the crisis.<sup>19</sup>

---

<sup>12</sup> City of Berkeley Human Resources, “Job Descriptions” accessed 2.4.2019

<http://agency.governmentjobs.com/berkeley/default.cfm?action=agencyspecs&agencyID=1568>

<sup>13</sup> Romem, Issa and Elizabeth Kneebone, 2018. “Disparity in Departure: Who Leaves the Bay Area and Where Do They Go?” <https://turnercenter.berkeley.edu/disparity-in-departure>

<sup>14</sup> Berkeley Rentals, <https://www.zillow.com/berkeley-ca/home-values/>

<sup>15</sup> D'Souza, Karen, 2/3/19. “You think Bay Area housing is expensive? Child care costs are rising, too.” <https://www.mercurynews.com/2019/02/03/you-think-bay-area-housing-is-expensive-childcare-costs-are-rising-too/amp/>

<sup>16</sup> The U.S. Census The Supplemental Poverty Measure adjusts thresholds based on cost of living indexes.

<sup>17</sup> SPUR: Ideas and Action for a Better City. “Homelessness in the Bay Area: Solving the problem of homelessness is arguably our region's greatest challenge.” Molly Turner, Urbanist Article, October 23, 2017 <https://www.spur.org/publications/urbanist-article/2017-10-23/homelessness-bay-area>

<sup>18</sup> Berkeley Homeless Point-in-Time Count and Survey Data, 2017. [https://www.cityofberkeley.info/Clerk/City\\_Council/2017/07\\_Jul/Documents/2017-07-25\\_Item\\_53\\_2017\\_Berkeley\\_Homeless.aspxn](https://www.cityofberkeley.info/Clerk/City_Council/2017/07_Jul/Documents/2017-07-25_Item_53_2017_Berkeley_Homeless.aspxn)

<sup>19</sup> *Homeless in America, Homeless in California*. John M. Quigley, Steven Raphael, and Eugene Smolensky. The Review of Economics and Statistics, February 2001, 83(1): 37–51 © 2001 by the

## **BACKGROUND**

### **Missing Middle**

*What is missing middle housing?*

Missing middle housing is a term used to describe:

1. a range of clustered or multi-unit housing types compatible in scale with single family homes<sup>20</sup> and/or
2. housing types naturally affordable to those earning between 80-120% of the area median income.

While this legislation aims to address the former, by definition and design, missing middle housing will always be less expensive than comparable single family homes in the same neighborhood, leading to greater accessibility to those earning median, middle, or lower incomes. Currently, the median price of a single family home in Berkeley is \$1.2 million dollars, which is out of reach for the majority of working people.<sup>21</sup> Approximately half of Berkeley's housing stock consists of single family units<sup>22</sup> and more than half of Berkeley's residential land is zoned in ways that preclude most missing middle housing. As a result, today, only wealthy households can afford homes in Berkeley.

---

President and Fellows of Harvard College and the Massachusetts Institute of Technology.  
[https://urbanpolicy.berkeley.edu/pdf/qrs\\_restat01pb.pdf](https://urbanpolicy.berkeley.edu/pdf/qrs_restat01pb.pdf)

<sup>20</sup> Parolek, Dan. Opticos Design. <http://missingmiddlehousing.com/>

<sup>21</sup> Berkeley Home Prices and Values, <https://www.zillow.com/berkeley-ca/home-values/>

<sup>22</sup> City of Berkeley 2015 -2023 Housing Element.

[https://www.cityofberkeley.info/uploadedFiles/Planning\\_and\\_Development/Level\\_3\\_-\\_Commissions/Commission\\_for\\_Planning/2015-2023%20Berkeley%20Housing%20Element\\_FINAL.pdf](https://www.cityofberkeley.info/uploadedFiles/Planning_and_Development/Level_3_-_Commissions/Commission_for_Planning/2015-2023%20Berkeley%20Housing%20Element_FINAL.pdf)

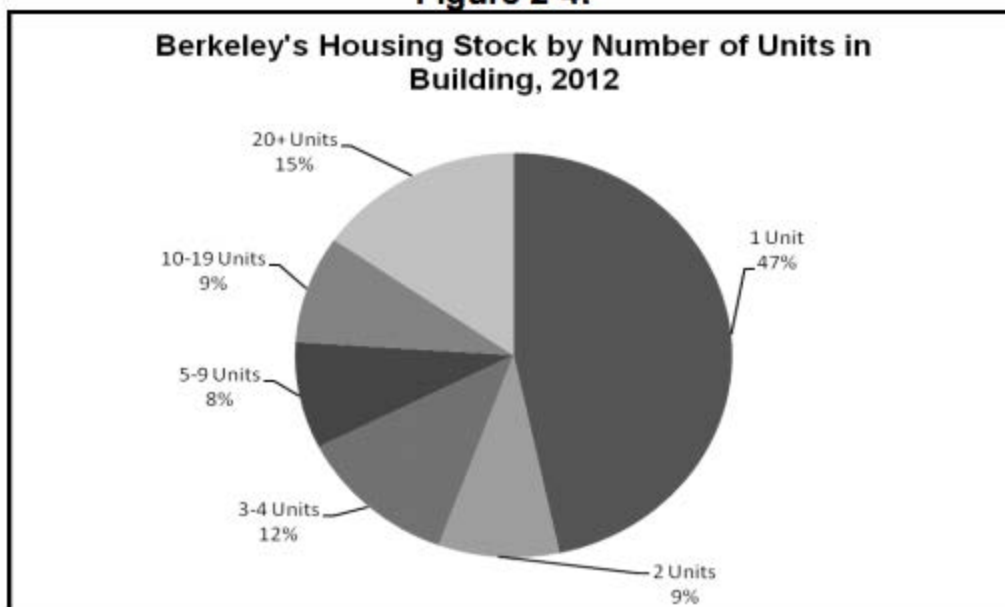
**Figure 2-4:**

Source: US Census, ACS 2008-2012 5-Year Estimate., Table B25024

Missing middle housing includes duplexes, triplexes, courtyard apartments, bungalow courts, and multiplexes that often house people with a variety of incomes. These housing types generally have small- to medium-sized footprints and are often three stories or less, allowing them to blend into the existing neighborhood while still encouraging greater socioeconomic diversity. These types of homes exist in every district of Berkeley, having been built before they were banned in districts only allowing single family homes. Missing middle homes were severely limited in other districts by zoning changes initiated in 1973.

One study found that individuals trying to create missing middle housing cannot compete financially with larger projects in areas zoned for higher density, noting “many smaller developers have difficulty obtaining the necessary resources (including the competitive funding) required to offset the high initial per-unit development costs, and larger developers with deeper pockets and more experience navigating complex regulatory systems will almost always opt to build projects that are large enough to achieve the bulk per-unit development rate.”<sup>23</sup> Additionally, missing middle housing is not permitted in areas zoned R1 (single family family only). Other factors that may prevent the creation of missing middle housing include onerous lot coverage ratios and excessive setback and parking requirements.<sup>24</sup>

<sup>23</sup> The Montgomery Planning Dept., “The Missing Middle Housing Study,” September 2018. [http://montgomeryplanning.org/wp-content/uploads/2018/09/MissingMiddleHousingStudy\\_9-2018.pdf](http://montgomeryplanning.org/wp-content/uploads/2018/09/MissingMiddleHousingStudy_9-2018.pdf)

<sup>24</sup> Ibid.

## History of Exclusionary Zoning, Racial and Economic Segregation and Current Zoning

Prior to the 1970s, a variety of missing middle housing was still being produced and made available to families throughout the Bay Area, particularly in Berkeley. Many triplexes, etc exist in areas now zoned for single family residential (R-1), limited two-family residential (R-1A), and restricted two-family residential (R-2). These areas are now some of the most expensive parts of our city—especially on a per-unit basis.

Until 1984, Martin Luther King Jr Way was known as Grove Street. For decades, Grove Street created a wall of segregation down the center of Berkeley. Asian-Americans and African-Americans could not live east of Grove Street due to race-restrictive covenants that barred them from purchasing or leasing property.<sup>25</sup> While many people are aware of this sordid piece of Berkeley history, less know about Mason-McDuffie Company's use of zoning laws and racially-restrictive property deeds and covenants to prevent people of color from living in east Berkeley.

Mason-McDuffie race-restrictive covenants state: "if prior to the first day of January 1930 any person of African or Mongolian descent shall be allowed to purchase or lease said property or any part thereof, then this conveyance shall be and become void..."<sup>26</sup> In 1916, McDuffie began lobbying for the exclusionary zoning ordinances in Berkeley to protect against the "disastrous effects of uncontrolled development"<sup>27</sup> and restrict Chinese laundromats and African American dance halls, particularly in the Elmwood and Claremont neighborhoods.<sup>28</sup>

After *Buchanan v Wareley* in 1917, explicit racially restrictive zoning became illegal. However, consideration to maintaining the character of districts became paramount and Mason-McDuffie contracts still stipulated that property owners must be white.

In 1933, the federal government created a Home Owners Loan Corporation (HOLC), which produced residential maps of neighborhoods to identify mortgage lending risks for real estate agents, lenders, etc. These maps were based on racial composition, quality of housing stock, access to amenities, etc. and were color coded to identify best (green), still desirable (blue), definitely declining (yellow), and hazardous (red)

<sup>25</sup> Wollenberg, *Berkeley, A City in History*, 2008.

<sup>26</sup> Claremont Park Company Indenture, 1910

<sup>27</sup> Lory, Maya Tulip. "A History of Racial Segregation, 1878–1960." *The Concord Review*, 2013. <http://www.schoolinfosystem.org/pdf/2014/06/04SegregationinCA24-2.pdf>

<sup>28</sup> Weiss, M. A. (1986). Urban Land Developers and the Origins of Zoning Laws: The Case of Berkeley. *Berkeley Planning Journal*, 3(1). Retrieved from <https://escholarship.org/uc/item/26b8d8zh>

neighborhoods. These maps enabled discriminatory lending practices (later called 'redlining') and allowed lenders to enforce local segregation standards.<sup>29</sup>

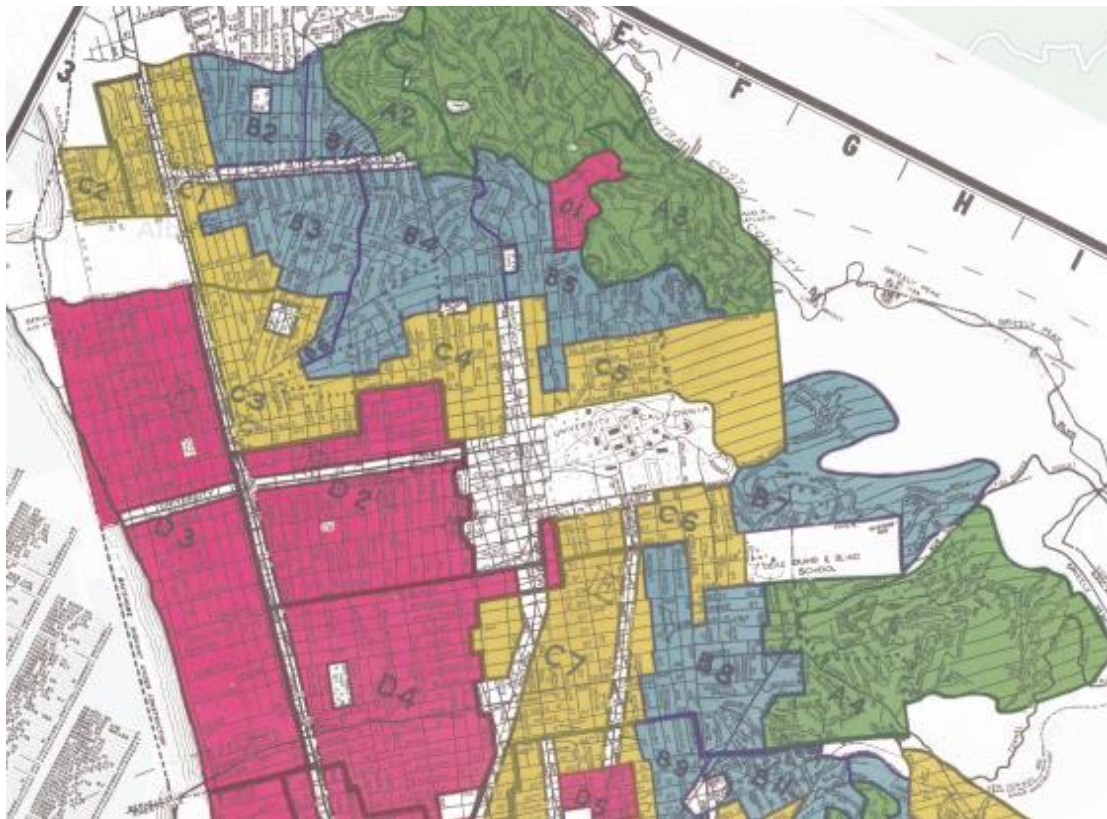

Thomas Bros Map of Oakland, Berkeley, Alameda, San Leandro, Piedmont Emeryville Albany. <https://dsl.richmond.edu/panorama/redlining/#loc=10/37.8201/-122.4399&opacity=0.8&sort=17&city=oakland-ca&advview=full> in Robert K. Nelson, LaDale Winling, Richard Marciano, Nathan Connolly, et al., "Mapping Inequality," *American Panorama*, ed. Robert K. Nelson and Edward L. Ayers, accessed January 24, 2019.

<sup>29</sup> NCRC Opening Doors to Economic Opportunity, "HOLC "REDLINING" MAPS: The persistent structure of segregation and economic inequality." Bruce Mitchell and Juan Franco. [https://ncrc.org/wp-content/uploads/dlm\\_uploads/2018/02/NCRC-Research-HOLC-10.pdf](https://ncrc.org/wp-content/uploads/dlm_uploads/2018/02/NCRC-Research-HOLC-10.pdf)

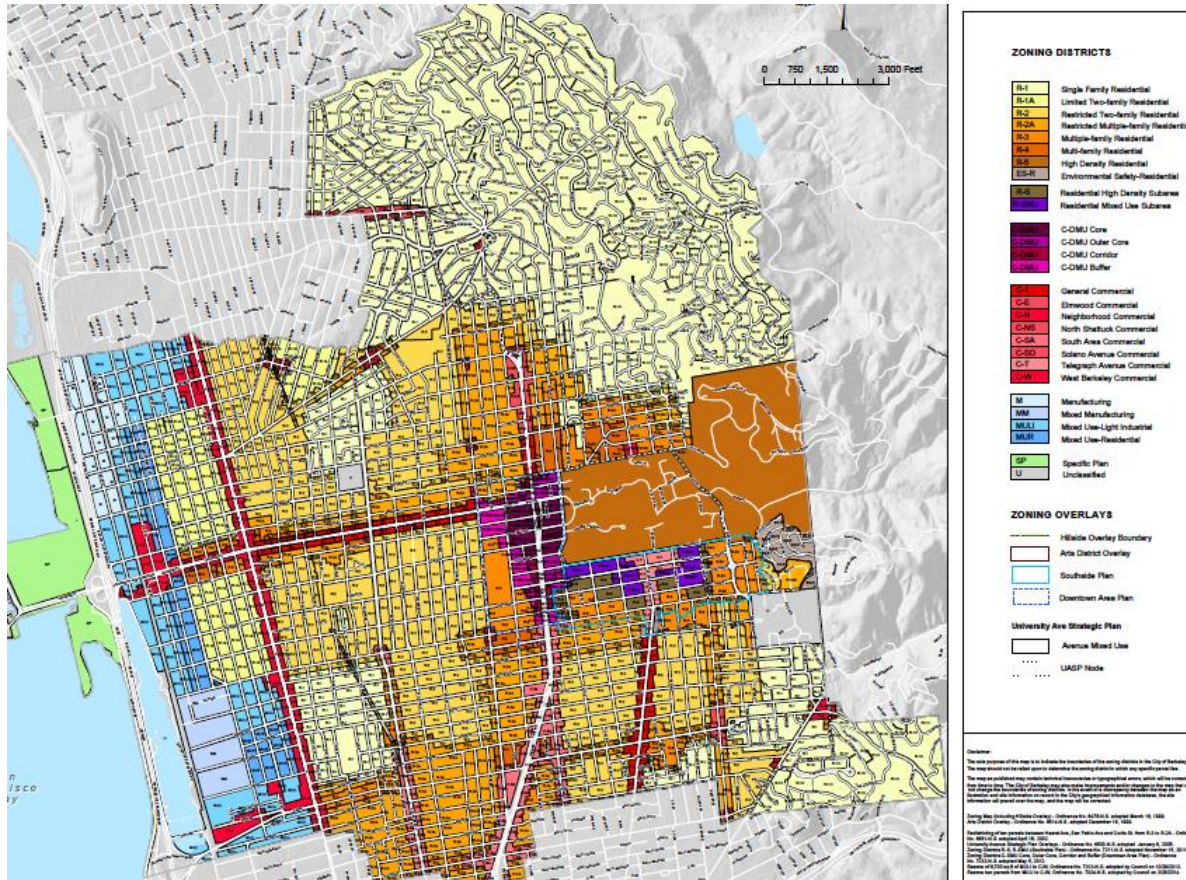

[The images above compare a HOLC-era map of Berkeley with a current zoning map. Neighborhoods identified as “best” in green on the HOLC-era map typically remain zoned as single family residential areas today. Red ‘hazardous’ neighborhoods in the first map are now largely zoned as manufacturing, mixed use, light industrial, or limited two family residential.]

Most cities still retain the vestiges of exclusionary zoning practices. By restricting desirable areas to single-family homes (and banning less expensive housing options, such as duplexes, tri-/four-plexes, courtyard apartments, bungalow courts, and townhouses), the current zoning map dictates that only wealthier families will be able to live or rent in Berkeley. Today, with the median sale price at \$1.2 million, this de-facto form of segregation is even more pronounced.

According to the data mapped by the Urban Displacement Project, most of the low-income tracts in Berkeley are at-risk or have ongoing displacement and gentrification. Higher-income tracts in Berkeley are classified as ‘at-risk of exclusion’, currently feature ‘ongoing exclusion’, or are at stages of ‘advanced exclusion’. Degrees of exclusion are measured by a combination of data: the loss of low-income households over time, presence of high income households, being considered in a ‘hot housing market,’ and migration patterns. The Urban Displacement Project’s findings indicate that exclusion is



more prevalent than gentrification in the Bay Area.<sup>30</sup> While Berkeley has created policies and designated funding to prevent gentrification, policies that focus on preventing exclusion have lagged.

### **TENANT AND ANTI-DISPLACEMENT STRATEGIES**

The types of zoning modifications that may result from the requested report could, as discussed above, significantly increase Berkeley’s housing stock with units that are more affordable to low- and middle-income residents. However, staff’s report should consider possible side effects and ways that policy can be crafted to prevent and mitigate negative externalities which could affect tenants and low-income homeowners. Steps must be taken to address the possibility that altering, demolishing, remodeling, or moving existing structures doesn’t result in the widespread displacement of Berkeley tenants or loss of rent-controlled units. Staff should consider what measures are needed in conjunction with these zoning changes (e.g. strengthening the demolition ordinance, tenant protections or assistance, no net loss requirements or prohibiting owners from applying if housing was occupied by tenants five years preceding date of application).

### **ALTERNATIVE ACTIONS CONSIDERED**

We considered an urgency ordinance but after consultation with City of Berkeley staff, we are recommending a report on potential zoning changes to inform future policy decisions, as opposed to immediate zoning revisions.

### **IMPLEMENTATION, ADMINISTRATION, AND ENFORCEMENT**

Not applicable as this item requests an analytical report.

### **FINANCIAL IMPLICATIONS**

Staffing or consulting costs to analyze zoning code and produce the report.

### **ENVIRONMENTAL SUSTAINABILITY**

Berkeley declared a climate emergency in 2018. Among other concerns, wildfires and sea level rise are constant ecological threats to our community. The City of Berkeley needs to act urgently to address this imminent danger. Last year, climate researchers in Berkeley quantified local and state opportunities to reduce greenhouse gases from a “comprehensive consumption-based perspective.”<sup>31</sup> The most impactful local policy to potentially reduce greenhouse gas consumption by 2030 is urban infill. In short,

---

<sup>30</sup> Zuk, M., & Chapple, K. (2015). Urban Displacement Project. <http://www.urbandisplacement.org/map/sf>

<sup>31</sup> “Carbon Footprint Planning: Quantifying Local and State Mitigation Opportunities for 700 California Cities.” Christopher M. Jones, Stephen M. Wheeler, and Daniel M. Kammen. Urban Planning (ISSN: 2183–7635) 2018, Volume 3, Issue 2. <https://rael.berkeley.edu/wp-content/uploads/2018/04/Jones-Wheeler-Kammen-700-California-Cities-Carbon-Footprint-2018.pdf>

Berkeley can meaningfully address climate change if we allow the production of more homes near job centers and transit.

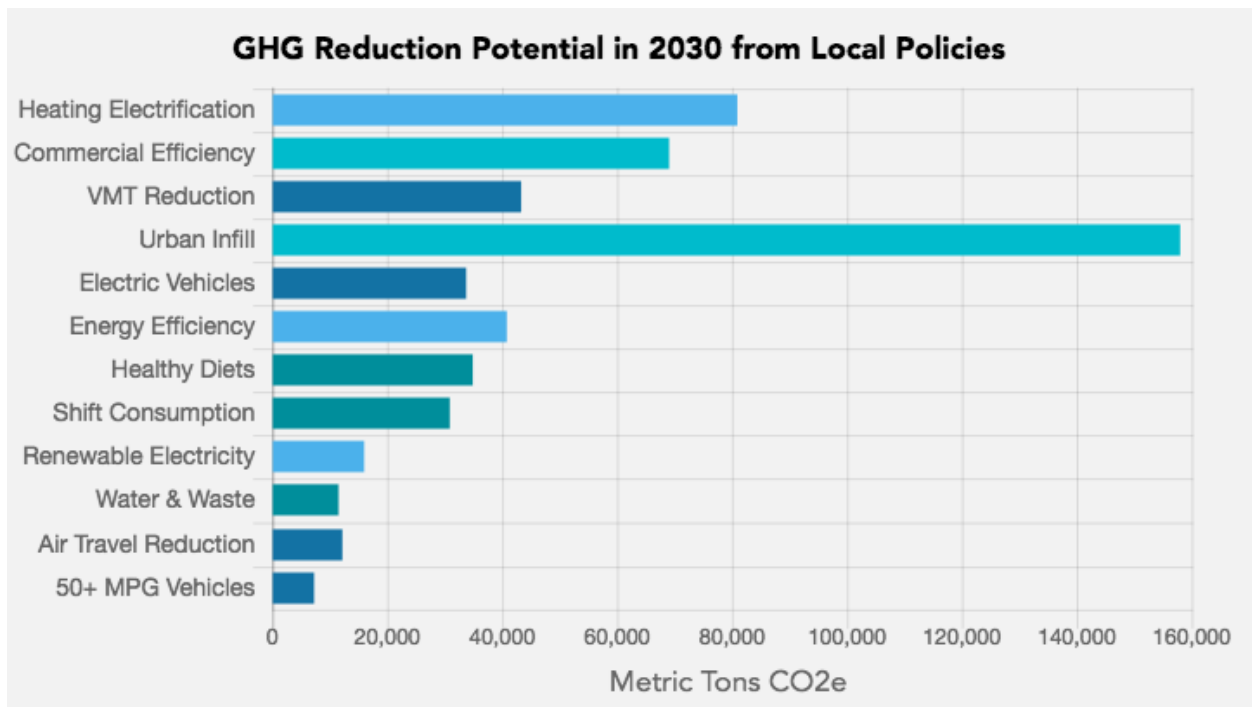

**CONTACT PERSON(S):**

Lori Droste, 510-981-7180

**ATTACHMENTS:**

Minneapolis Plan:

[https://minneapolis2040.com/media/1428/pdf\\_minneapolis2040\\_with\\_appendices.pdf](https://minneapolis2040.com/media/1428/pdf_minneapolis2040_with_appendices.pdf)

Seattle' Plan:

<http://www.seattle.gov/Documents/Departments/SeattlePlanningCommission/SPCNeighborhoodsForAllFINAL121318digital.pdf>

## **Berkeleyside**

### **Opinion: We can design our way out of Berkeley's housing crisis with 'missing middle' buildings**

*A Berkeley architect argues that Berkeley should build more small-scale, multi-unit buildings such as duplexes, bungalow courts, fourplexes, and small mansion apartments.*

By Daniel Parolek

Dec. 19, 2017

Berkeley's housing problems have gone national recently, as The New York Times' Conor Dougherty highlighted in a thought-provoking article, "The Great American Single-Family Home Problem." Dougherty examines the conflicting interests and regulations that threatened to halt the development of one lot on Haskell Street, and shows how those conflicting forces are contributing to the affordable housing crisis we are seeing in our state – and across the country.

As an architect and urban designer based in Berkeley for the past 20 years, I agree that California municipalities have an urgent need to deliver more housing. That said, just delivering more housing is not enough. We need to think about how this housing reinforces a high quality built environment and how to provide a range of housing for all segments of the market, including moderate and low-income households. More small-scale, multi-unit buildings such as duplexes, bungalow courts, fourplexes, and small mansion apartments, or what I call "Missing Middle Housing," should be a key focus of that housing.

Unfortunately, the design proposed for the Haskell Street site in Berkeley does not deliver on reinforcing a high quality built environment or affordability and, as the NYT article makes clear, does not deliver on any level of affordability. There are better design solutions that deliver a more compatible form, that have more and a broader range of housing units, and that can be more effective at building local support for this and similar infill projects.

For example, the 50' x 150' lot at 310 Haskell Street is big enough to accommodate a traditional fourplex, with two units down and two units above in a building that is the scale of a house (see image attached from our Missing Middle research). The units would typically be between 750-900 square feet each. An important characteristic of this housing type is that they do not go deeper onto the lot than a traditional house, thus eliminating the concern about privacy and shading and providing high-quality outdoor living spaces. These fourplex housing types exist all over Berkeley and are often successfully integrated onto blocks with single-family homes.

So how do we get there? Berkeley and most cities across the country need to sharpen their pencils on their outdated zoning codes, first to remove barriers for better solutions and secondly, to create a set of regulations that ensure that inappropriate design solutions like the one proposed for Haskell Street or even worse are not allowed on these sites. Lower densities do not equal better design solutions and higher densities do not need to mean larger or more buildings. This is a delicate balance that few zoning codes achieve and few code writers fully

understand.

We also need to change the way we communicate about housing needs in our communities. If we are using George Lakoff's rules for effective communication we would never go into a housing conversation with a community and use terms like "increasing density, adding multi-family, or upzoning a neighborhood." I can think of few neighborhoods that would feel good about saying yes to any of those options if they were framed in that way, but which can mostly get on board with thinking about aging within a neighborhood, or ensuring their kids or grandkids can afford to move back to the city they grew up in. Beginning this conversation by simply showing photographic and/or local existing documented examples of good Missing Middle housing types often disarms this conversation and leads to more fruitful results.

Berkeley's challenges related to housing are not going to go away anytime soon. We need to thoughtfully remove barriers to enable a broad range of solutions like the fourplex that have been a core part of choices provided in our communities already and learn how to effectively build consensus and support for good design solutions such as Missing Middle housing types.

*Daniel Parolek is an architect and urban designer who co-authored the book "Form-Based Codes," coined the term Missing Middle Housing ([www.missingmiddlehousing.com](http://www.missingmiddlehousing.com)) and speaks and consults nationally on these topics.*



Lori Droste  
Councilmember, District 8

## **REVISED AGENDA MATERIAL for Supplemental Packet 1**

**Meeting Date:** February 26, 2019

**Item Number:** 22

**Item Description:** **Missing Middle Report**

**Submitted by:** Councilmember Lori Droste, Councilmember Ben Bartlett,  
Councilmember Rigel Robinson, and Councilmember Rashi Kesarwani

This item has been revised to include considerations for scaling of floor to area ratios, land value recapture.



Lori Droste  
Councilmember, District 8

**ACTION CALENDAR**  
February 26, 2019

**To:** Members of the City Council

**From:** Councilmember Lori Droste, Councilmember Ben Bartlett, Councilmember Rigel Robinson, and Councilmember Rashi Kesarwani

**Subject:** Missing Middle Report

**RECOMMENDATION**

Refer to the City Manager to bring back to Council a report of potential revisions to the zoning code to foster a broader range of housing types across Berkeley, particularly missing middle housing types (duplexes, triplexes/fourplexes, courtyard apartments, bungalow courts, townhouses, etc.), in areas with access to essential components of livability like parks, schools, employment, transit, and other services.

Report should include, but is not limited to:

- Identifying where missing middle housing is optimal/~~should be permitted~~
- Allowing the possibility of existing houses/footprints/zoning envelopes to be divided into up to 4 units, potentially scaling the floor area ratio (FAR) to increase as the number of units increase on site, creating homes that are more affordable, saving and lightly modifying an older structure as part of internally dividing it into more than one unit.<sup>1</sup>
- Excluding very high fire severity zones as defined by ~~the~~ Cal Fire and/or City of Berkeley.

---

<sup>1</sup> City of Portland, <https://www.portlandoregon.gov/bps/article/711691>.

- Considering form-based zoning as a potential strategy<sup>2</sup>,
- Creating incentives to maintain family-friendly housing stock while adding more diversity and range of smaller units
- Creating incentives for building more than one unit on larger than average lots,
- Considering provision of tenant protections, demolition controls, and no net loss provisions
- Considering provisions that align with our land value recapture policy objectives to maximize affordability in Berkeley.

### **CURRENT PROBLEM AND ITS EFFECTS**

The nine-county Bay Area region is facing an extreme shortage of homes that are affordable for working families. The Metropolitan Transportation Commission illustrates the job-housing imbalance in a recently released a report showing that only one home is added for every 3.5 jobs created in the Bay Area region.<sup>3</sup> Governor Gavin Newsom has called for a “Marshall Plan for affordable housing” and has pledged to create millions of more homes in California to tackle the state’s affordability and homelessness crisis.

In Berkeley, the median sale price of a home is \$1.2 million (as of December 2018)—an increase of 65% over the median sale price in December 2013 of \$727,000. Similarly, Berkeley’s median rent index is \$3,663/month—a 54% increase since since December 2013.<sup>4</sup> The escalating rents coincide with an increase of 17% in Berkeley’s homeless population as documented in the 2015 and 2017 point-in-time counts.<sup>5</sup> These skyrocketing housing costs put extreme pressure on low-, moderate- and middle-income households, as they are forced to spend an increasing percentage share of their income on housing (leaving less for other necessities like food and medicine), live in overcrowded conditions, or endure super-commutes of 90 minutes or more in order to make ends meet.

#### *Low-Income Households*

Recently, low-income households experienced the greatest increases in rent as a portion of their monthly income. According to the Urban Displacement Project, households are considered to be “rent burdened” when more than a third of their income goes toward housing costs. In Alameda County, “Although rent burden increased across all income groups, it rose most substantially for low- and very low-

<sup>2</sup> Form-Based Codes Institute at Smart Growth America, 1152 15th Street NW Ste. 450 Washington, DC 20005. <https://formbasedcodes.org/definition/>

<sup>3</sup> Metropolitan Transportation Commission, 2018. <http://www.vitalsigns.mtc.ca.gov/>

<sup>4</sup> Berkeley Home Prices and Values, <https://www.zillow.com/berkeley-ca/home-values/>

<sup>5</sup> Berkeley Homeless Point-in-Time Count and Survey Data, 2017. [https://www.cityofberkeley.info/Clerk/City\\_Council/2017/07\\_Jul/Documents/2017-07-25\\_Item\\_53\\_2017\\_Berkeley\\_Homeless.aspx](https://www.cityofberkeley.info/Clerk/City_Council/2017/07_Jul/Documents/2017-07-25_Item_53_2017_Berkeley_Homeless.aspx)

income households. In both 2000 and 2015, extremely low-income renters were by far the most likely to experience severe rent burden, with nearly three quarters spending more than half their income on rent.”<sup>6</sup>

Although residents of Berkeley recently passed Measure O which will substantially increase funding for affordable housing, low-income units are increasingly expensive to create. Low-income housing units typically cost well over \$500,000 to create and the demand for this type of affordable/subsidized housing exceeds the supply.<sup>7</sup> In Berkeley, roughly 700 seniors applied for the 42 affordable/subsidized units at Harpers Crossings.<sup>8</sup> Without a substantial additional increase in funding for affordable housing, the vast majority of low-income individuals have to rely on the market.

### *Middle-Income Households*

In the Bay Area, those earning middle incomes are facing similar challenges in finding affordable homes. The Pew Research Center classifies middle income households as those with “adults whose annual household income is two-thirds to double the national median.” In 2016, middle income households were those earning approximately \$45,000 to \$136,000 for a household of three.<sup>9</sup> However, in Berkeley, a similarly-sized family earning up to \$80,650 (80% Area Median Income) is considered low-income according to the U.S. Department of Housing and Urban Development.<sup>10</sup>

In the Bay Area, a family currently has to earn \$200,000 annually to afford the principal, interest, taxes and insurance payments on a median-priced home in the Bay Area (assuming they can pay 20 percent of the median home price of nearly \$1,000,000 up front).<sup>11</sup> This means that many City of Berkeley employees couldn’t afford to live where they work: a community health worker (making \$63,600) and a janitor (making \$58,300) wouldn’t be able to afford a home. Neither would a fire captain (making \$142,000) with a

<sup>6</sup> Zuk, M., & Chapple, K. (2015). Urban Displacement Project.

[http://www.urbandisplacement.org/sites/default/files/images/alameda\\_final.pdf](http://www.urbandisplacement.org/sites/default/files/images/alameda_final.pdf)

<sup>7</sup> “The Cost of Building Housing” *The Turner Center* <https://turnercenter.berkeley.edu/construction-costs-series>

<sup>8</sup> Flood, Lucy. (1/18/2018). “Berkeley low-income seniors get a fresh start at Harper Crossing.”

<https://www.berkeleyside.com/2018/01/18/berkeley-low-income-seniors-get-fresh-start-harper-crossing>

<sup>9</sup> Kochhar, Rakesh. “The American middle class is stable in size, but losing ground financially to upper-income families,” 9/16/2018, Pew Research Center. <http://www.pewresearch.org/fact-tank/2018/09/06/the-american-middle-class-is-stable-in-size-but-losing-ground-financially-to-upper-income-families/>

<sup>10</sup> Berkeley Housing Authority, HUD Income Guidelines, effective April 1, 2018. [https://www.cityofberkeley.info/BHA/Home/Payment\\_Standards,\\_Income\\_Limits,\\_and\\_Utility\\_Allowance.aspx](https://www.cityofberkeley.info/BHA/Home/Payment_Standards,_Income_Limits,_and_Utility_Allowance.aspx)

<sup>11</sup> “The salary you must earn to buy a home in the 50 largest metros” (10/14/2018). HSH.com <https://www.hsh.com/finance/mortgage/salary-home-buying-25-cities.html#>



stay at home spouse. Even a police officer (making \$122,600) and a groundskeeper (making \$69,300), or two librarians (making \$71,700) couldn't buy a house.<sup>12</sup>

### *Families*

Many families are fleeing the Bay Area due to the high cost of living. According to a recently released study by the Turner Center for Housing Innovation, the income and racial patterns out-migration and in-migration indicate that “the region risks backsliding on inclusion and diversity and displacing its economically vulnerable and minority residents to areas of more limited opportunity.”<sup>13</sup> Rent for a two bedroom apartment in Berkeley costs approximately \$3,200/month<sup>14</sup> while the median child care cost in Alameda County is \$1,824 a month, an increase of 36% in the past four years.<sup>15</sup> Consequently, many families are paying well over \$60,000 for living and childcare expenses alone.

### *Homelessness*

High housing costs also lead to California having among the highest rates of poverty in the nation at 19%.<sup>16</sup> Consequently, homelessness is on the rise throughout California. The Bay Area has one of the largest and least-sheltered homeless populations in North America.<sup>17</sup> The proliferation of homeless encampments—from select urban neighborhoods to locations across the region—is the most visible manifestation of the Bay Area's extreme housing affordability crisis. According to the 2017 point-in-time count, Berkeley had approximately 972 individuals experiencing homelessness on any given night.<sup>18</sup> In order to help homeless individuals get housed, the City needs to create more homes. Tighter housing markets are associated with higher rates of homelessness, indicating that the creation of additional housing for all income levels is key to mitigating the crisis.<sup>19</sup>

<sup>12</sup> City of Berkeley Human Resources, “Job Descriptions” accessed 2.4.2019

<http://agency.governmentjobs.com/berkeley/default.cfm?action=agencyspecs&agencyID=1568>

<sup>13</sup> Romem, Issa and Elizabeth Kneebone, 2018. “Disparity in Departure: Who Leaves the Bay Area and Where Do They Go?” <https://turnercenter.berkeley.edu/disparity-in-departure>

<sup>14</sup> Berkeley Rentals, <https://www.zillow.com/berkeley-ca/home-values/>

<sup>15</sup> D'Souza, Karen, 2/3/19. “You think Bay Area housing is expensive? Child care costs are rising, too.” <https://www.mercurynews.com/2019/02/03/you-think-bay-area-housing-is-expensive-childcare-costs-are-rising-too/amp/>

<sup>16</sup> The U.S. Census The Supplemental Poverty Measure adjusts thresholds based on cost of living indexes.

<sup>17</sup> SPUR: Ideas and Action for a Better City. “Homelessness in the Bay Area: Solving the problem of homelessness is arguably our region's greatest challenge.” Molly Turner, Urbanist Article, October 23, 2017 <https://www.spur.org/publications/urbanist-article/2017-10-23/homelessness-bay-area>

<sup>18</sup> Berkeley Homeless Point-in-Time Count and Survey Data, 2017. [https://www.cityofberkeley.info/Clerk/City\\_Council/2017/07\\_Jul/Documents/2017-07-25\\_Item\\_53\\_2017\\_Berkeley\\_Homeless.aspxn](https://www.cityofberkeley.info/Clerk/City_Council/2017/07_Jul/Documents/2017-07-25_Item_53_2017_Berkeley_Homeless.aspxn)

<sup>19</sup> *Homeless in America, Homeless in California*. John M. Quigley, Steven Raphael, and Eugene Smolensky. The Review of Economics and Statistics, February 2001, 83(1): 37–51 © 2001 by the

## **BACKGROUND**

### **Missing Middle**

*What is missing middle housing?*

Missing middle housing is a term used to describe:

1. a range of clustered or multi-unit housing types compatible in scale with single family homes<sup>20</sup> and/or
2. housing types naturally affordable to those earning between 80-120% of the area median income.

While this legislation aims to address the former, by definition and design, missing middle housing will always be less expensive than comparable single family homes in the same neighborhood, leading to greater accessibility to those earning median, middle, or lower incomes. Currently, the median price of a single family home in Berkeley is \$1.2 million dollars, which is out of reach for the majority of working people.<sup>21</sup> Approximately half of Berkeley's housing stock consists of single family units<sup>22</sup> and more than half of Berkeley's residential land is zoned in ways that preclude most missing middle housing. As a result, today, only wealthy households can afford homes in Berkeley.

---

President and Fellows of Harvard College and the Massachusetts Institute of Technology.  
[https://urbanpolicy.berkeley.edu/pdf/qrs\\_restat01pb.pdf](https://urbanpolicy.berkeley.edu/pdf/qrs_restat01pb.pdf)

<sup>20</sup> Parolek, Dan. Opticos Design. <http://missingmiddlehousing.com/>

<sup>21</sup> Berkeley Home Prices and Values, <https://www.zillow.com/berkeley-ca/home-values/>

<sup>22</sup> City of Berkeley 2015 -2023 Housing Element.

[https://www.cityofberkeley.info/uploadedFiles/Planning\\_and\\_Development/Level\\_3\\_-\\_Commissions/Commission\\_for\\_Planning/2015-2023%20Berkeley%20Housing%20Element\\_FINAL.pdf](https://www.cityofberkeley.info/uploadedFiles/Planning_and_Development/Level_3_-_Commissions/Commission_for_Planning/2015-2023%20Berkeley%20Housing%20Element_FINAL.pdf)

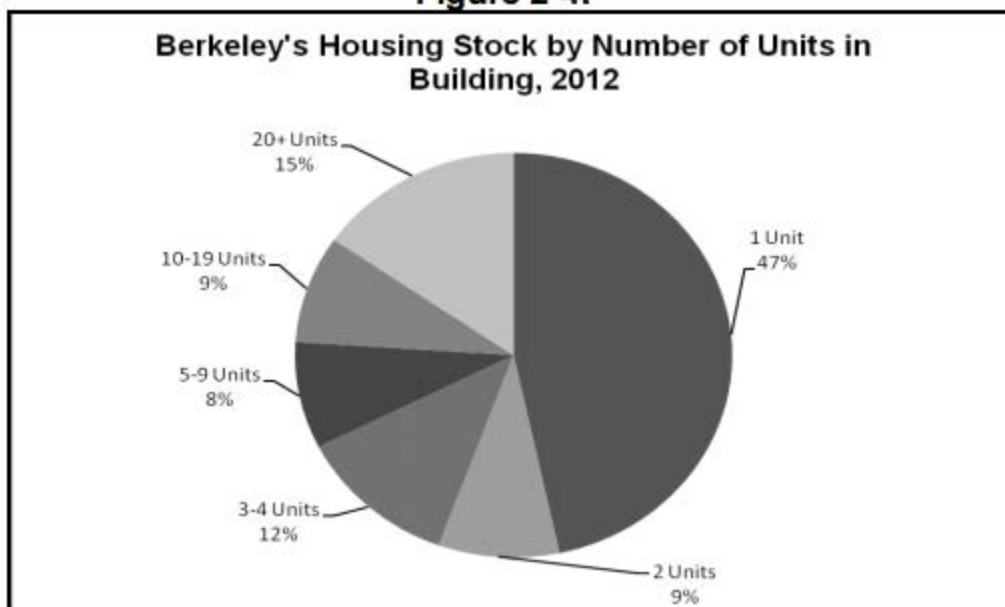
**Figure 2-4:**

Source: US Census, ACS 2008-2012 5-Year Estimate., Table B25024

Missing middle housing includes duplexes, triplexes, courtyard apartments, bungalow courts, and multiplexes that often house people with a variety of incomes. These housing types generally have small- to medium-sized footprints and are often three stories or less, allowing them to blend into the existing neighborhood while still encouraging greater socioeconomic diversity. These types of homes exist in every district of Berkeley, having been built before they were banned in districts only allowing single family homes. Missing middle homes were severely limited in other districts by zoning changes initiated in 1973.

One study found that individuals trying to create missing middle housing cannot compete financially with larger projects in areas zoned for higher density, noting “many smaller developers have difficulty obtaining the necessary resources (including the competitive funding) required to offset the high initial per-unit development costs, and larger developers with deeper pockets and more experience navigating complex regulatory systems will almost always opt to build projects that are large enough to achieve the bulk per-unit development rate.”<sup>23</sup> Additionally, missing middle housing is not permitted in areas zoned R1 (single family family only). Other factors that may prevent the creation of missing middle housing include onerous lot coverage ratios and excessive setback and parking requirements.<sup>24</sup>

<sup>23</sup> The Montgomery Planning Dept., “The Missing Middle Housing Study,” September 2018. [http://montgomeryplanning.org/wp-content/uploads/2018/09/MissingMiddleHousingStudy\\_9-2018.pdf](http://montgomeryplanning.org/wp-content/uploads/2018/09/MissingMiddleHousingStudy_9-2018.pdf)

<sup>24</sup> Ibid.

## History of Exclusionary Zoning, Racial and Economic Segregation and Current Zoning

Prior to the 1970s, a variety of missing middle housing was still being produced and made available to families throughout the Bay Area, particularly in Berkeley. Many triplexes, etc exist in areas now zoned for single family residential (R-1), limited two-family residential (R-1A), and restricted two-family residential (R-2). These areas are now some of the most expensive parts of our city—especially on a per-unit basis.

Until 1984, Martin Luther King Jr Way was known as Grove Street. For decades, Grove Street created a wall of segregation down the center of Berkeley. Asian-Americans and African-Americans could not live east of Grove Street due to race-restrictive covenants that barred them from purchasing or leasing property.<sup>25</sup> While many people are aware of this sordid piece of Berkeley history, less know about Mason-McDuffie Company's use of zoning laws and racially-restrictive property deeds and covenants to prevent people of color from living in east Berkeley.

Mason-McDuffie race-restrictive covenants state: "if prior to the first day of January 1930 any person of African or Mongolian descent shall be allowed to purchase or lease said property or any part thereof, then this conveyance shall be and become void..."<sup>26</sup> In 1916, McDuffie began lobbying for the exclusionary zoning ordinances in Berkeley to protect against the "disastrous effects of uncontrolled development"<sup>27</sup> and restrict Chinese laundromats and African American dance halls, particularly in the Elmwood and Claremont neighborhoods.<sup>28</sup>

After *Buchanan v Wareley* in 1917, explicit racially restrictive zoning became illegal. However, consideration to maintaining the character of districts became paramount and Mason-McDuffie contracts still stipulated that property owners must be white.

In 1933, the federal government created a Home Owners Loan Corporation (HOLC), which produced residential maps of neighborhoods to identify mortgage lending risks for real estate agents, lenders, etc. These maps were based on racial composition, quality of housing stock, access to amenities, etc. and were color coded to identify best (green), still desirable (blue), definitely declining (yellow), and hazardous (red)

---

<sup>25</sup> Wollenberg, *Berkeley, A City in History*, 2008.

<sup>26</sup> Claremont Park Company Indenture, 1910

<sup>27</sup> Lory, Maya Tulip. "A History of Racial Segregation, 1878–1960." *The Concord Review*, 2013. <http://www.schoolinfosystem.org/pdf/2014/06/04SegregationinCA24-2.pdf>

<sup>28</sup> Weiss, M. A. (1986). Urban Land Developers and the Origins of Zoning Laws: The Case of Berkeley. *Berkeley Planning Journal*, 3(1). Retrieved from <https://escholarship.org/uc/item/26b8d8zh>

neighborhoods. These maps enabled discriminatory lending practices (later called 'redlining') and allowed lenders to enforce local segregation standards.<sup>29</sup>

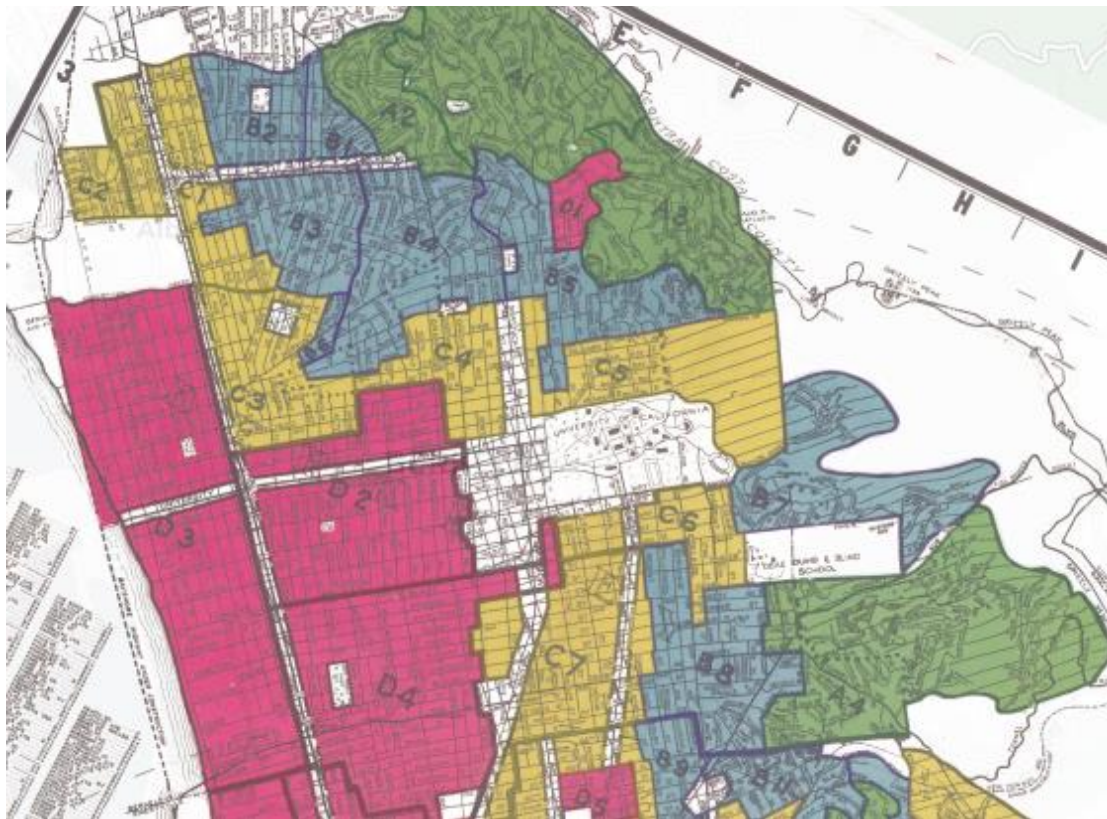

Thomas Bros Map of Oakland, Berkeley, Alameda, San Leandro, Piedmont Emeryville Albany.  
<https://dsl.richmond.edu/panorama/redlining/#loc=10/37.8201/-122.4399&opacity=0.8&sort=17&city=oakland-ca&advview=full> in Robert K. Nelson, LaDale Winling, Richard Marciano, Nathan Connolly, et al., "Mapping Inequality," *American Panorama*, ed. Robert K. Nelson and Edward L. Ayers, accessed January 24, 2019.

<sup>29</sup> NCRC Opening Doors to Economic Opportunity, "HOLC "REDLINING" MAPS: The persistent structure of segregation and economic inequality." Bruce Mitchell and Juan Franco. [https://ncrc.org/wp-content/uploads/dlm\\_uploads/2018/02/NCRC-Research-HOLC-10.pdf](https://ncrc.org/wp-content/uploads/dlm_uploads/2018/02/NCRC-Research-HOLC-10.pdf)

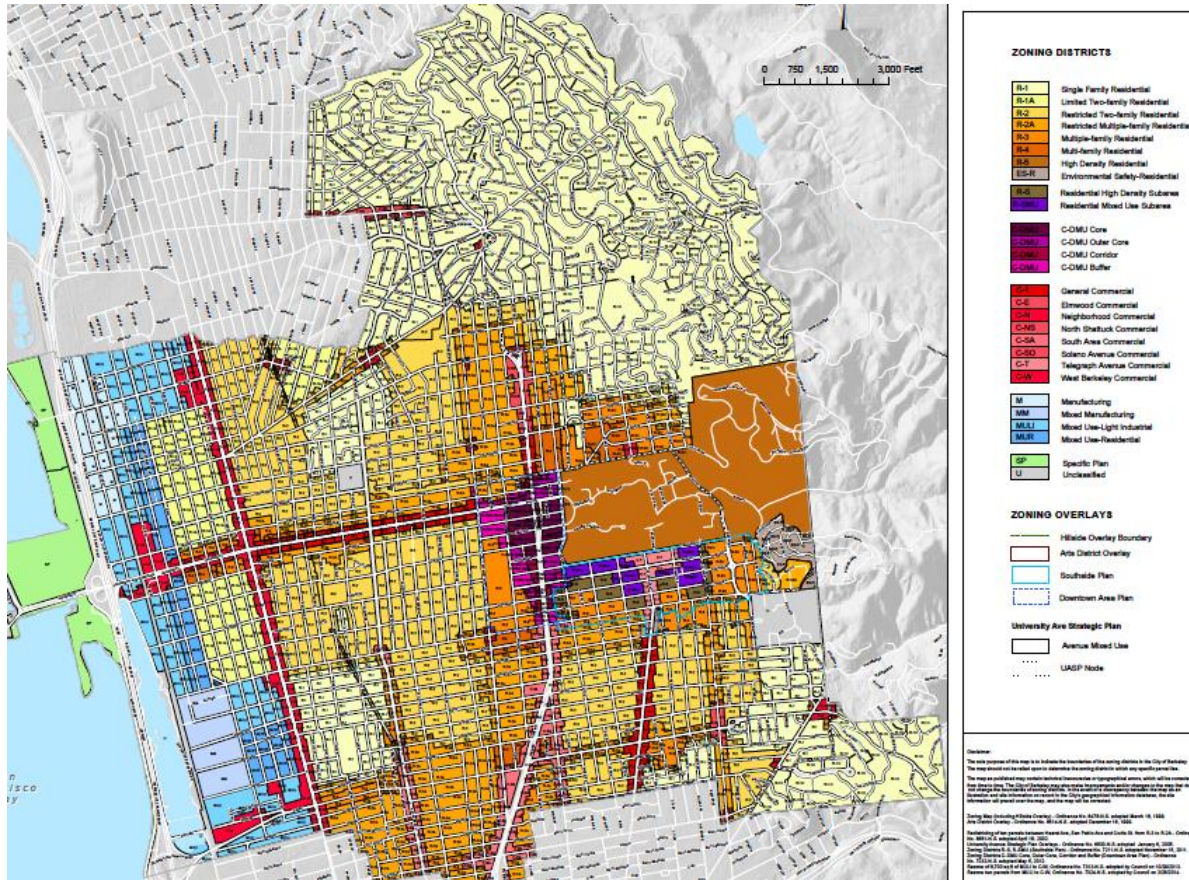

[The images above compare a HOLC-era map of Berkeley with a current zoning map. Neighborhoods identified as “best” in green on the HOLC-era map typically remain zoned as single family residential areas today. Red ‘hazardous’ neighborhoods in the first map are now largely zoned as manufacturing, mixed use, light industrial, or limited two family residential.]

Most cities still retain the vestiges of exclusionary zoning practices. By restricting desirable areas to single-family homes (and banning less expensive housing options, such as duplexes, tri-/four-plexes, courtyard apartments, bungalow courts, and townhouses), the current zoning map dictates that only wealthier families will be able to live or rent in Berkeley. Today, with the median sale price at \$1.2 million, this de-facto form of segregation is even more pronounced.

According to the data mapped by the Urban Displacement Project, most of the low-income tracts in Berkeley are at-risk or have ongoing displacement and gentrification. Higher-income tracts in Berkeley are classified as ‘at-risk of exclusion’, currently feature ‘ongoing exclusion’, or are at stages of ‘advanced exclusion’. Degrees of exclusion are measured by a combination of data: the loss of low-income households over time, presence of high income households, being considered in a ‘hot housing market,’ and migration patterns. The Urban Displacement Project’s findings indicate that exclusion is

more prevalent than gentrification in the Bay Area.<sup>30</sup> While Berkeley has created policies and designated funding to prevent gentrification, policies that focus on preventing exclusion have lagged.

### **TENANT AND ANTI-DISPLACEMENT STRATEGIES**

The types of zoning modifications that may result from the requested report could, as discussed above, significantly increase Berkeley’s housing stock with units that are more affordable to low- and middle-income residents. However, staff’s report should consider possible side effects and ways that policy can be crafted to prevent and mitigate negative externalities which could affect tenants and low-income homeowners. Steps must be taken to address the possibility that altering, demolishing, remodeling, or moving existing structures doesn’t result in the widespread displacement of Berkeley tenants or loss of rent-controlled units. Staff should consider what measures are needed in conjunction with these zoning changes (e.g. strengthening the demolition ordinance, tenant protections or assistance, no net loss requirements or prohibiting owners from applying if housing was occupied by tenants five years preceding date of application).

### **ALTERNATIVE ACTIONS CONSIDERED**

We considered an urgency ordinance but after consultation with City of Berkeley staff, we are recommending a report on potential zoning changes to inform future policy decisions, as opposed to immediate zoning revisions.

### **IMPLEMENTATION, ADMINISTRATION, AND ENFORCEMENT**

Not applicable as this item requests an analytical report.

### **FINANCIAL IMPLICATIONS**

Staffing or consulting costs to analyze zoning code and produce the report.

### **ENVIRONMENTAL SUSTAINABILITY**

Berkeley declared a climate emergency in 2018. Among other concerns, wildfires and sea level rise are constant ecological threats to our community. The City of Berkeley needs to act urgently to address this imminent danger. Last year, climate researchers in Berkeley quantified local and state opportunities to reduce greenhouse gases from a “comprehensive consumption-based perspective.”<sup>31</sup> The most impactful local policy to potentially reduce greenhouse gas consumption by 2030 is urban infill. In short,

<sup>30</sup> Zuk, M., & Chapple, K. (2015). Urban Displacement Project. <http://www.urbandisplacement.org/map/sf>

<sup>31</sup> “Carbon Footprint Planning: Quantifying Local and State Mitigation Opportunities for 700 California Cities.” Christopher M. Jones, Stephen M. Wheeler, and Daniel M. Kammen. Urban Planning (ISSN: 2183–7635) 2018, Volume 3, Issue 2. <https://rael.berkeley.edu/wp-content/uploads/2018/04/Jones-Wheeler-Kammen-700-California-Cities-Carbon-Footprint-2018.pdf>

Berkeley can meaningfully address climate change if we allow the production of more homes near job centers and transit.

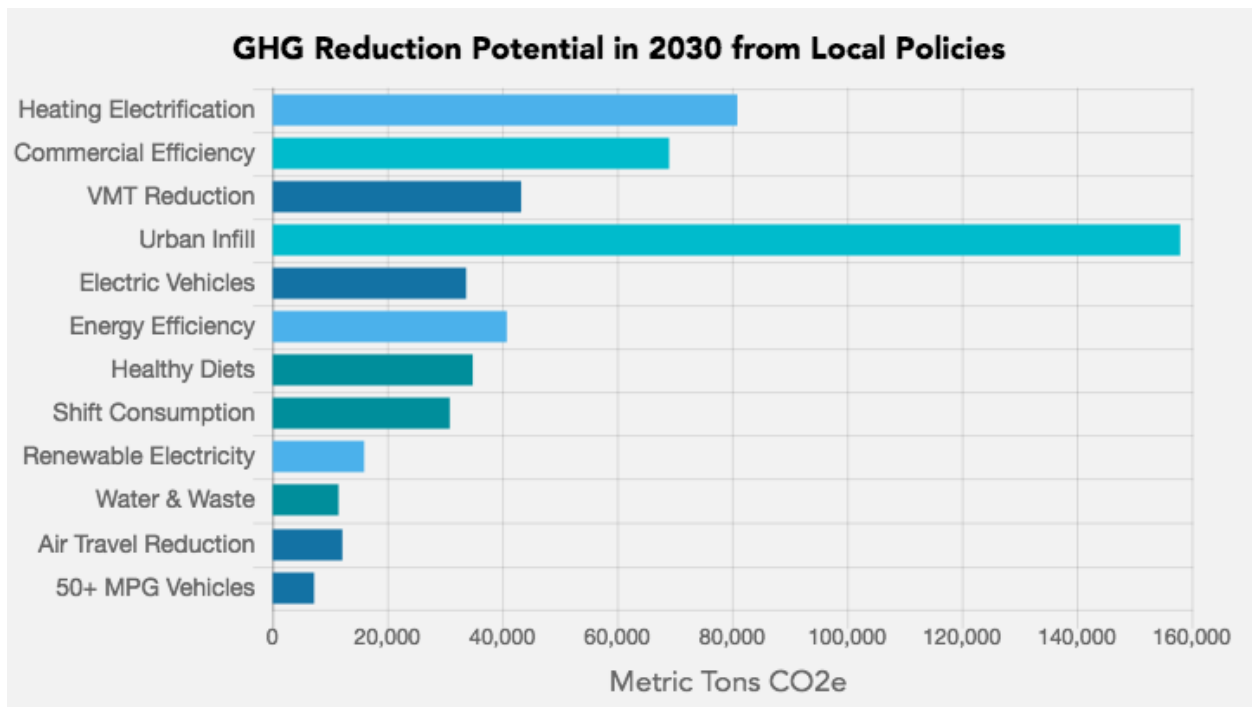

**CONTACT PERSON(S):**

Lori Droste, 510-981-7180

**ATTACHMENTS:**

Minneapolis Plan:

[https://minneapolis2040.com/media/1428/pdf\\_minneapolis2040\\_with\\_appendices.pdf](https://minneapolis2040.com/media/1428/pdf_minneapolis2040_with_appendices.pdf)

Seattle' Plan:

<http://www.seattle.gov/Documents/Departments/SeattlePlanningCommission/SPCNeighborhoodsForAllFINAL121318digital.pdf>



## **Berkeleyside**

### **Opinion: We can design our way out of Berkeley's housing crisis with 'missing middle' buildings**

*A Berkeley architect argues that Berkeley should build more small-scale, multi-unit buildings such as duplexes, bungalow courts, fourplexes, and small mansion apartments.*

By Daniel Parolek

Dec. 19, 2017

Berkeley's housing problems have gone national recently, as The New York Times' Conor Dougherty highlighted in a thought-provoking article, "The Great American Single-Family Home Problem." Dougherty examines the conflicting interests and regulations that threatened to halt the development of one lot on Haskell Street, and shows how those conflicting forces are contributing to the affordable housing crisis we are seeing in our state – and across the country.

As an architect and urban designer based in Berkeley for the past 20 years, I agree that California municipalities have an urgent need to deliver more housing. That said, just delivering more housing is not enough. We need to think about how this housing reinforces a high quality built environment and how to provide a range of housing for all segments of the market, including moderate and low-income households. More small-scale, multi-unit buildings such as duplexes, bungalow courts, fourplexes, and small mansion apartments, or what I call "Missing Middle Housing," should be a key focus of that housing.

Unfortunately, the design proposed for the Haskell Street site in Berkeley does not deliver on reinforcing a high quality built environment or affordability and, as the NYT article makes clear, does not deliver on any level of affordability. There are better design solutions that deliver a more compatible form, that have more and a broader range of housing units, and that can be more effective at building local support for this and similar infill projects.

For example, the 50' x 150' lot at 310 Haskell Street is big enough to accommodate a traditional fourplex, with two units down and two units above in a building that is the scale of a house (see image attached from our Missing Middle research). The units would typically be between 750-900 square feet each. An important characteristic of this housing type is that they do not go deeper onto the lot than a traditional house, thus eliminating the concern about privacy and shading and providing high-quality outdoor living spaces. These fourplex housing types exist all over Berkeley and are often successfully integrated onto blocks with single-family homes.

So how do we get there? Berkeley and most cities across the country need to sharpen their pencils on their outdated zoning codes, first to remove barriers for better solutions and secondly, to create a set of regulations that ensure that inappropriate design solutions like the one proposed for Haskell Street or even worse are not allowed on these sites. Lower densities do not equal better design solutions and higher densities do not need to mean larger or more buildings. This is a delicate balance that few zoning codes achieve and few code writers fully

understand.

We also need to change the way we communicate about housing needs in our communities. If we are using George Lakoff's rules for effective communication we would never go into a housing conversation with a community and use terms like "increasing density, adding multi-family, or upzoning a neighborhood." I can think of few neighborhoods that would feel good about saying yes to any of those options if they were framed in that way, but which can mostly get on board with thinking about aging within a neighborhood, or ensuring their kids or grandkids can afford to move back to the city they grew up in. Beginning this conversation by simply showing photographic and/or local existing documented examples of good Missing Middle housing types often disarms this conversation and leads to more fruitful results.

Berkeley's challenges related to housing are not going to go away anytime soon. We need to thoughtfully remove barriers to enable a broad range of solutions like the fourplex that have been a core part of choices provided in our communities already and learn how to effectively build consensus and support for good design solutions such as Missing Middle housing types.

*Daniel Parolek is an architect and urban designer who co-authored the book "Form-Based Codes," coined the term Missing Middle Housing ([www.missingmiddlehousing.com](http://www.missingmiddlehousing.com)) and speaks and consults nationally on these topics.*



Lori Droste  
Berkeley City Councilmember, District 8

## **ACTION CALENDAR**

April 23, 2019

*(Continued from March 26, 2019)*

**To:** Members of the City Council

**From:** Councilmember Lori Droste, Councilmember Ben Bartlett, Councilmember Rigel Robinson, and Councilmember Rashi Kesarwani

**Subject:** Missing Middle Report

### RECOMMENDATION

Refer to the City Manager to bring back to Council a report of potential revisions to the zoning code to foster a broader range of housing types across Berkeley, particularly missing middle housing types (duplexes, triplexes/fourplexes, courtyard apartments, bungalow courts, townhouses, etc.), in areas with access to essential components of livability like parks, schools, employment, transit, and other services.

Report should include, but is not limited to:

- Identifying where missing middle housing is optimal/should be permitted
- Allowing the possibility of existing houses/footprints/zoning envelopes to be divided up to 4 units
- Excluding very high fire severity zones as defined by the CalFire and/or the City of Berkeley
- Considering form-based zoning as a potential strategy<sup>1</sup>

---

<sup>1</sup> Form-Based Codes Institute at Smart Growth America, 1152 15th Street NW Ste. 450 Washington, DC 20005. <https://formbasedcodes.org/definition/>

- Creating incentives to maintain family-friendly housing stock while adding more diversity and range of smaller units
- Creating incentives for building more than one unit on larger than average lots
- Provision of tenant protections, demolition controls, and no net loss provisions

### **CURRENT PROBLEM AND ITS EFFECTS**

The nine-county Bay Area region is facing an extreme shortage of homes that are affordable for working families. The Metropolitan Transportation Commission illustrates the job-housing imbalance in a recently released a report showing that only one home is added for every 3.5 jobs created in the Bay Area region.<sup>2</sup> Governor Gavin Newsom has called for a “Marshall Plan for affordable housing” and has pledged to create millions of more homes in California to tackle the state’s affordability and homelessness crisis.

In Berkeley, the median sale price of a home is \$1.2 million (as of December 2018)—an increase of 65% over the median sale price in December 2013 of \$727,000. Similarly, Berkeley’s median rent index is \$3,663/month—a 54% increase since since December 2013.<sup>3</sup> The escalating rents coincide with an increase of 17% in Berkeley’s homeless population as documented in the 2015 and 2017 point-in-time counts.<sup>4</sup> These skyrocketing housing costs put extreme pressure on low-, moderate- and middle-income households, as they are forced to spend an increasing percentage share of their income on housing (leaving less for other necessities like food and medicine), live in overcrowded conditions, or endure super-commutes of 90 minutes or more in order to make ends meet.

#### *Low-Income Households*

Recently, low-income households experienced the greatest increases in rent as a portion of their monthly income. According to the Urban Displacement Project, households are considered to be “rent burdened” when more than a third of their income goes toward housing costs. In Alameda County, “Although rent burden increased across all income groups, it rose most substantially for low- and very low-income households. In both 2000 and 2015, extremely low-income renters were by far the most likely to experience severe rent burden, with nearly three quarters spending more than half their income on rent.”<sup>5</sup>

---

<sup>2</sup> Metropolitan Transportation Commission, 2018. <http://www.vitalsigns.mtc.ca.gov/>

<sup>3</sup> Berkeley Home Prices and Values, <https://www.zillow.com/berkeley-ca/home-values/>

<sup>4</sup> Berkeley Homeless Point-in-Time Count and Survey Data, 2017. [https://www.cityofberkeley.info/Clerk/City\\_Council/2017/07\\_Jul/Documents/2017-07-25\\_Item\\_53\\_2017\\_Berkeley\\_Homeless.aspx](https://www.cityofberkeley.info/Clerk/City_Council/2017/07_Jul/Documents/2017-07-25_Item_53_2017_Berkeley_Homeless.aspx)

<sup>5</sup> Zuk, M., & Chapple, K. (2015). Urban Displacement Project. [http://www.urbandisplacement.org/sites/default/files/images/alameda\\_final.pdf](http://www.urbandisplacement.org/sites/default/files/images/alameda_final.pdf)

Although residents of Berkeley recently passed Measure O which will substantially increase funding for affordable housing, low-income units are increasingly expensive to create. Low-income housing units typically cost well over \$500,000 to create and the demand for this type of affordable/subsidized housing exceeds the supply.<sup>6</sup> In Berkeley, roughly 700 seniors applied for the 42 affordable/subsidized units at Harpers Crossings.<sup>7</sup> Without a substantial additional increase in funding for affordable housing, the vast majority of low-income individuals have to rely on the market.

### *Middle-Income Households*

In the Bay Area, those earning middle incomes are facing similar challenges in finding affordable homes. The Pew Research Center classifies middle income households as those with “adults whose annual household income is two-thirds to double the national median.” In 2016, middle income households were those earning approximately \$45,000 to \$136,000 for a household of three.<sup>8</sup> However, in Berkeley, a similarly-sized family earning up to \$80,650 (80% Area Median Income) is considered low-income according to the U.S. Department of Housing and Urban Development.<sup>9</sup>

In the Bay Area, a family currently has to earn \$200,000 annually to afford the principal, interest, taxes and insurance payments on a median-priced home in the Bay Area (assuming they can pay 20 percent of the median home price of nearly \$1,000,000 up front).<sup>10</sup> This means that many City of Berkeley employees couldn’t afford to live where they work: a community health worker (making \$63,600) and a janitor (making \$58,300) wouldn’t be able to afford a home. Neither would a fire captain (making \$142,000) with a stay at home spouse. Even a police officer (making \$122,600) and a groundskeeper (making \$69,300), or two librarians (making \$71,700) couldn’t buy a house.<sup>11</sup>

### *Families*

---

<sup>6</sup> “The Cost of Building Housing” *The Turner Center* <https://turnercenter.berkeley.edu/construction-costs-series>

<sup>7</sup> Flood, Lucy. (1/18/2018). “Berkeley low-income seniors get a fresh start at Harper Crossing.” <https://www.berkeleyside.com/2018/01/18/berkeley-low-income-seniors-get-fresh-start-harper-crossing>

<sup>8</sup> Kochhar, Rakesh. “The American middle class is stable in size, but losing ground financially to upper-income families,” 9/16/2018, Pew Research Center. <http://www.pewresearch.org/fact-tank/2018/09/06/the-american-middle-class-is-stable-in-size-but-losing-ground-financially-to-upper-income-families/>

<sup>9</sup> Berkeley Housing Authority, HUD Income Guidelines, effective April 1, 2018. [https://www.cityofberkeley.info/BHA/Home/Payment\\_Standards,\\_Income\\_Limits,\\_and\\_Utility\\_Allowance.aspx](https://www.cityofberkeley.info/BHA/Home/Payment_Standards,_Income_Limits,_and_Utility_Allowance.aspx)

<sup>10</sup> “The salary you must earn to buy a home in the 50 largest metros” (10/14/2018). HSH.com <https://www.hsh.com/finance/mortgage/salary-home-buying-25-cities.html#>

<sup>11</sup> City of Berkeley Human Resources, “Job Descriptions” accessed 2.4.2019 <http://agency.governmentjobs.com/berkeley/default.cfm?action=agencyspecs&agencyID=1568>

Many families are fleeing the Bay Area due to the high cost of living. According to a recently released study by the Turner Center for Housing Innovation, the income and racial patterns out-migration and in-migration indicate that “the region risks backsliding on inclusion and diversity and displacing its economically vulnerable and minority residents to areas of more limited opportunity.”<sup>12</sup> Rent for a two bedroom apartment in Berkeley costs approximately \$3,200/month<sup>13</sup> while the median child care cost in Alameda County is \$1,824 a month, an increase of 36% in the past four years.<sup>14</sup> Consequently, many families are paying well over \$60,000 for living and childcare expenses alone.

### *Homelessness*

High housing costs also lead to California having among the highest rates of poverty in the nation at 19%.<sup>15</sup> Consequently, homelessness is on the rise throughout California. The Bay Area has one of the largest and least-sheltered homeless populations in North America.<sup>16</sup> The proliferation of homeless encampments—from select urban neighborhoods to locations across the region—is the most visible manifestation of the Bay Area’s extreme housing affordability crisis. According to the 2017 point-in-time count, Berkeley had approximately 972 individuals experiencing homelessness on any given night.<sup>17</sup> In order to help homeless individuals get housed, the City needs to create more homes. Tighter housing markets are associated with higher rates of homelessness, indicating that the creation of additional housing for all income levels is key to mitigating the crisis.<sup>18</sup>

## **BACKGROUND**

### **Missing Middle**

---

<sup>12</sup> Romem, Issa and Elizabeth Kneebone, 2018. “Disparity in Departure: Who Leaves the Bay Area and Where Do They Go?” <https://turnercenter.berkeley.edu/disparity-in-departure>

<sup>13</sup> Berkeley Rentals, <https://www.zillow.com/berkeley-ca/home-values/>

<sup>14</sup> D’Souza, Karen, 2/3/19. “You think Bay Area housing is expensive? Child care costs are rising, too.” <https://www.mercurynews.com/2019/02/03/you-think-bay-area-housing-is-expensive-childcare-costs-are-rising-too/amp/>

<sup>15</sup> The U.S. Census The Supplemental Poverty Measure adjusts thresholds based on cost of living indexes.

<sup>16</sup> SPUR: Ideas and Action for a Better City. “Homelessness in the Bay Area: Solving the problem of homelessness is arguably our region’s greatest challenge.” Molly Turner, Urbanist Article, October 23, 2017 <https://www.spur.org/publications/urbanist-article/2017-10-23/homelessness-bay-area>

<sup>17</sup> Berkeley Homeless Point-in-Time Count and Survey Data, 2017. [https://www.cityofberkeley.info/Clerk/City\\_Council/2017/07\\_Jul/Documents/2017-07-25\\_Item\\_53\\_2017\\_Berkeley\\_Homeless.aspx](https://www.cityofberkeley.info/Clerk/City_Council/2017/07_Jul/Documents/2017-07-25_Item_53_2017_Berkeley_Homeless.aspx)

<sup>18</sup> *Homeless in America, Homeless in California*. John M. Quigley, Steven Raphael, and Eugene Smolensky. The Review of Economics and Statistics, February 2001, 83(1): 37–51 © 2001 by the President and Fellows of Harvard College and the Massachusetts Institute of Technology. [https://urbanpolicy.berkeley.edu/pdf/qrs\\_restat01pb.pdf](https://urbanpolicy.berkeley.edu/pdf/qrs_restat01pb.pdf)

### *What is missing middle housing?*

Missing middle housing is a term used to describe:

1. a range of clustered or multi-unit housing types compatible in scale with single family homes<sup>19</sup> and/or
2. housing types naturally affordable to those earning between 80-120% of the area median income.

While this legislation aims to address the former, by definition and design, missing middle housing will always be less expensive than comparable single family homes in the same neighborhood, leading to greater accessibility to those earning median, middle, or lower incomes. Currently, the median price of a single family home in Berkeley is \$1.2 million dollars, which is out of reach for the majority of working people.<sup>20</sup> Approximately half of Berkeley's housing stock consists of single family units<sup>21</sup> and more than half of Berkeley's residential land is zoned in ways that preclude most missing middle housing. As a result, today, only wealthy households can afford homes in Berkeley.

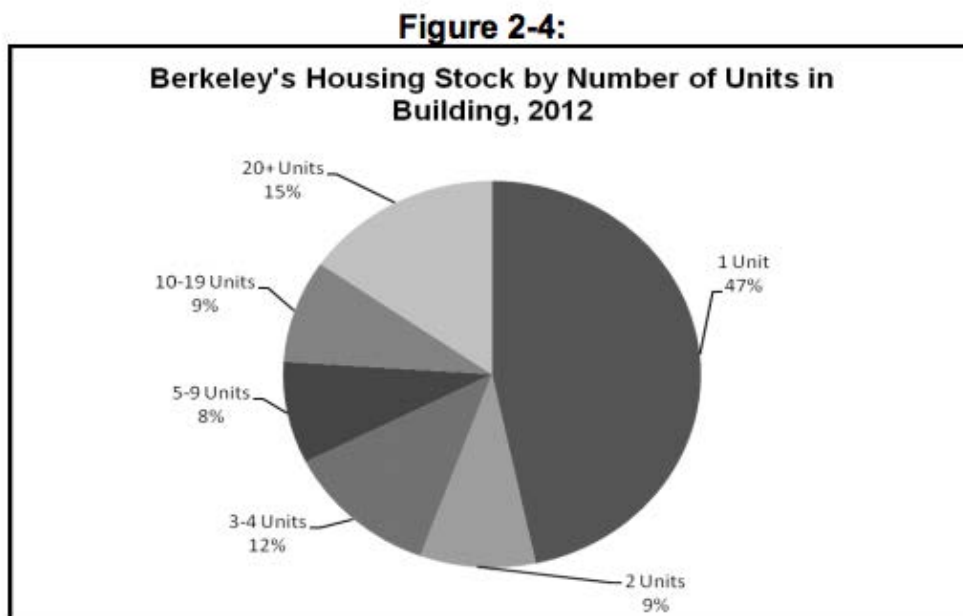

Source: US Census, ACS 2008-2012 5-Year Estimate., Table B25024

Missing middle housing includes duplexes, triplexes, courtyard apartments, bungalow courts, and multiplexes that often house people with a variety of incomes. These housing types generally have small- to medium-sized footprints and are often three

<sup>19</sup> Parolek, Dan. Opticos Design. <http://missingmiddlehousing.com/>

<sup>20</sup> Berkeley Home Prices and Values, <https://www.zillow.com/berkeley-ca/home-values/>

<sup>21</sup> City of Berkeley 2015 -2023 Housing Element.

[https://www.cityofberkeley.info/uploadedFiles/Planning\\_and\\_Development/Level\\_3\\_-\\_Commissions/Commission\\_for\\_Planning/2015-2023%20Berkeley%20Housing%20Element\\_FINAL.pdf](https://www.cityofberkeley.info/uploadedFiles/Planning_and_Development/Level_3_-_Commissions/Commission_for_Planning/2015-2023%20Berkeley%20Housing%20Element_FINAL.pdf)

stories or less, allowing them to blend into the existing neighborhood while still encouraging greater socioeconomic diversity. These types of homes exist in every district of Berkeley before they were banned in districts only allowing single family homes and missing middle homes were severely limited in other districts by zoning changes initiated in 1973.

One study found that individuals trying to create missing middle housing cannot compete financially with larger projects in areas zoned for higher density, noting “many smaller developers have difficulty obtaining the necessary resources (including the competitive funding) required to offset the high initial per-unit development costs, and larger developers with deeper pockets and more experience navigating complex regulatory systems will almost always opt to build projects that are large enough to achieve the bulk per-unit development rate.”<sup>22</sup> Additionally, missing middle housing is not permitted in areas zoned R1 (single family family only). Other factors that may prevent the creation of missing middle housing include onerous lot coverage ratios and excessive setback and parking requirements.<sup>23</sup>

### **History of Exclusionary Zoning, Racial and Economic Segregation and Current Zoning**

Prior to the 1970s, a variety of missing middle housing was still being produced and made available to families throughout the Bay Area, particularly in Berkeley. Many triplexes, etc exist in areas now zoned for single family residential (R-1), limited two-family residential (R-1A), and restricted two-family residential (R-2). These areas are now some of the most expensive parts of our city—especially on a per-unit basis.

Until 1984, Martin Luther King Jr Way was known as Grove Street. For decades, Grove Street created a wall of segregation down the center of Berkeley. Asian-Americans and African-Americans could not live east of Grove Street due to race-restrictive covenants that barred them from purchasing or leasing property.<sup>24</sup> While many people are aware of this sordid piece of Berkeley history, less know about Mason-McDuffie Company’s use of zoning laws and racially-restrictive property deeds and covenants to prevent people of color from living in east Berkeley.

Mason-McDuffie race-restrictive covenants state: “if prior to the first day of January 1930 any person of African or Mongolian descent shall be allowed to purchase or lease said property or any part thereof, then this conveyance shall be and become void...”<sup>25</sup> In

---

<sup>22</sup> The Montgomery Planning Dept., “The Missing Middle Housing Study,” September 2018. [http://montgomeryplanning.org/wp-content/uploads/2018/09/MissingMiddleHousingStudy\\_9-2018.pdf](http://montgomeryplanning.org/wp-content/uploads/2018/09/MissingMiddleHousingStudy_9-2018.pdf)

<sup>23</sup> Ibid.

<sup>24</sup> Wollenberg, *Berkeley, A City in History*, 2008.

<sup>25</sup> Claremont Park Company Indenture, 1910



1916, McDuffie began lobbying for the exclusionary zoning ordinances in Berkeley to protect against the “disastrous effects of uncontrolled development”<sup>26</sup> and restrict Chinese laundromats and African American dance halls, particularly in the Elmwood and Claremont neighborhoods.<sup>27</sup>

After *Buchanan v Wareley* in 1917, explicit racially restrictive zoning became illegal. However, consideration to maintaining the character of districts became paramount and Mason-McDuffie contracts still stipulated that property owners must be white.

In 1933, the federal government created a Home Owners Loan Corporation (HOLC), which produced residential maps of neighborhoods to identify mortgage lending risks for real estate agents, lenders, etc. These maps were based on racial composition, quality of housing stock, access to amenities, etc. and were color coded to identify best (green), still desirable (blue), definitely declining (yellow), and hazardous (red) neighborhoods. These maps enabled discriminatory lending practices (later called ‘redlining’) and allowed lenders to enforce local segregation standards.<sup>28</sup>

The images below compare a HOLC-era map of Berkeley with a current zoning map. Neighborhoods identified as “best” in green on the HOLC-era map typically remain zoned as single family residential areas today. Red ‘hazardous’ neighborhoods in the first map are now largely zoned as manufacturing, mixed use, light industrial, or limited two family residential.

---

<sup>26</sup> Lory, Maya Tulip. “A History of Racial Segregation, 1878–1960.” *The Concord Review*, 2013. <http://www.schoolinfosystem.org/pdf/2014/06/04SegregationinCA24-2.pdf>

<sup>27</sup> Weiss, M. A. (1986). Urban Land Developers and the Origins of Zoning Laws: The Case of Berkeley. *Berkeley Planning Journal*, 3(1). Retrieved from <https://escholarship.org/uc/item/26b8d8zh>

<sup>28</sup> NCRC Opening Doors to Economic Opportunity, “HOLC “REDLINING” MAPS: The persistent structure of segregation and economic inequality.” Bruce Mitchell and Juan Franco. [https://ncrc.org/wp-content/uploads/dlm\\_uploads/2018/02/NCRC-Research-HOLC-10.pdf](https://ncrc.org/wp-content/uploads/dlm_uploads/2018/02/NCRC-Research-HOLC-10.pdf)



Thomas Bros Map of Oakland, Berkeley, Alameda, San Leandro, Piedmont Emeryville Albany. <sup>29</sup>

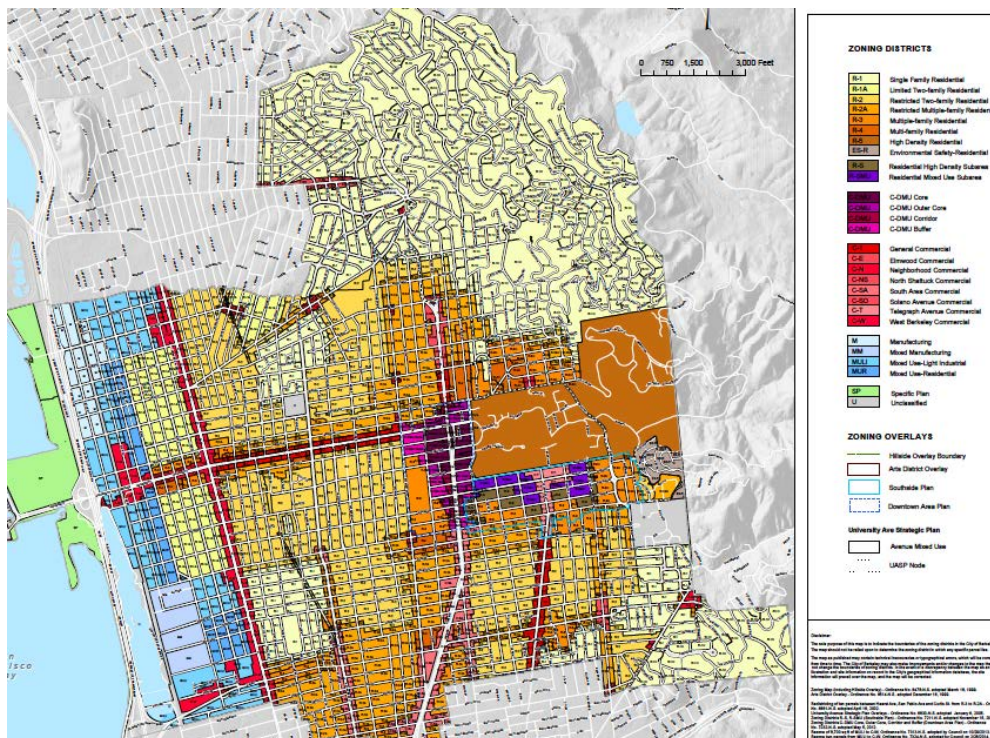

<sup>29</sup>Robert K. Nelson, LaDale Winling, Richard Marciano, Nathan Connolly, et al., "Mapping Inequality," *American Panorama*, ed. Robert K. Nelson and Edward L. Ayers, accessed January 24, 2019. <https://dsl.richmond.edu/panorama/redlining/#loc=10/37.8201/-122.4399&opacity=0.8&sort=17&city=oakland-ca&adviev=full in>

Most cities still retain the vestiges of exclusionary zoning practices. By restricting desirable areas to single-family homes (and banning less expensive housing options, such as duplexes, tri-/four-plexes, courtyard apartments, bungalow courts, and townhouses), the current zoning map dictates that only wealthier families will be able to live or rent in Berkeley. Today, with the median sale price at \$1.2 million, this de-facto form of segregation is even more pronounced.

According to the data mapped by the Urban Displacement Project, most of the low-income tracts in Berkeley are at-risk or have ongoing displacement and gentrification. Higher-income tracts in Berkeley are classified as ‘at-risk of exclusion’, currently feature ‘ongoing exclusion’, or are at stages of ‘advanced exclusion’. Degrees of exclusion are measured by a combination of data: the loss of low-income households over time, presence of high income households, being considered in a ‘hot housing market,’ and migration patterns. The Urban Displacement Project’s findings indicate that exclusion is more prevalent than gentrification in the Bay Area.<sup>30</sup> While Berkeley has created policies and designated funding to prevent gentrification, policies that focus on preventing exclusion have lagged.

### **ALTERNATIVE ACTIONS CONSIDERED**

We considered an urgency ordinance but after consultation with City of Berkeley staff, we are recommending a report on potential zoning changes to inform future policy decisions, as opposed to immediate zoning revisions.

### **IMPLEMENTATION, ADMINISTRATION, AND ENFORCEMENT**

Not applicable as this item requests an analytical report.

### **FINANCIAL IMPLICATIONS**

Staffing or consulting costs to analyze zoning code and produce the report.

### **ENVIRONMENTAL SUSTAINABILITY**

Berkeley declared a climate emergency in 2018. Among other concerns, wildfires and sea level rise are constant ecological threats to our community. The City of Berkeley needs to act urgently to address this imminent danger. Last year, climate researchers in Berkeley quantified local and state opportunities to reduce greenhouse gases from a “comprehensive consumption-based perspective.”<sup>31</sup> The most impactful local policy to

---

<sup>30</sup> Zuk, M., & Chapple, K. (2015). Urban Displacement Project. <http://www.urbandisplacement.org/map/sf>

<sup>31</sup> “Carbon Footprint Planning: Quantifying Local and State Mitigation Opportunities for 700 California Cities.” Christopher M. Jones, Stephen M. Wheeler, and Daniel M. Kammen. Urban Planning (ISSN: 2183–7635) 2018, Volume 3, Issue 2. <https://rael.berkeley.edu/wp-content/uploads/2018/04/Jones-Wheeler-Kammen-700-California-Cities-Carbon-Footprint-2018.pdf>

potentially reduce greenhouse gas consumption by 2030 is urban infill. In short, Berkeley can meaningfully address climate change if we allow the production of more homes near job centers and transit.

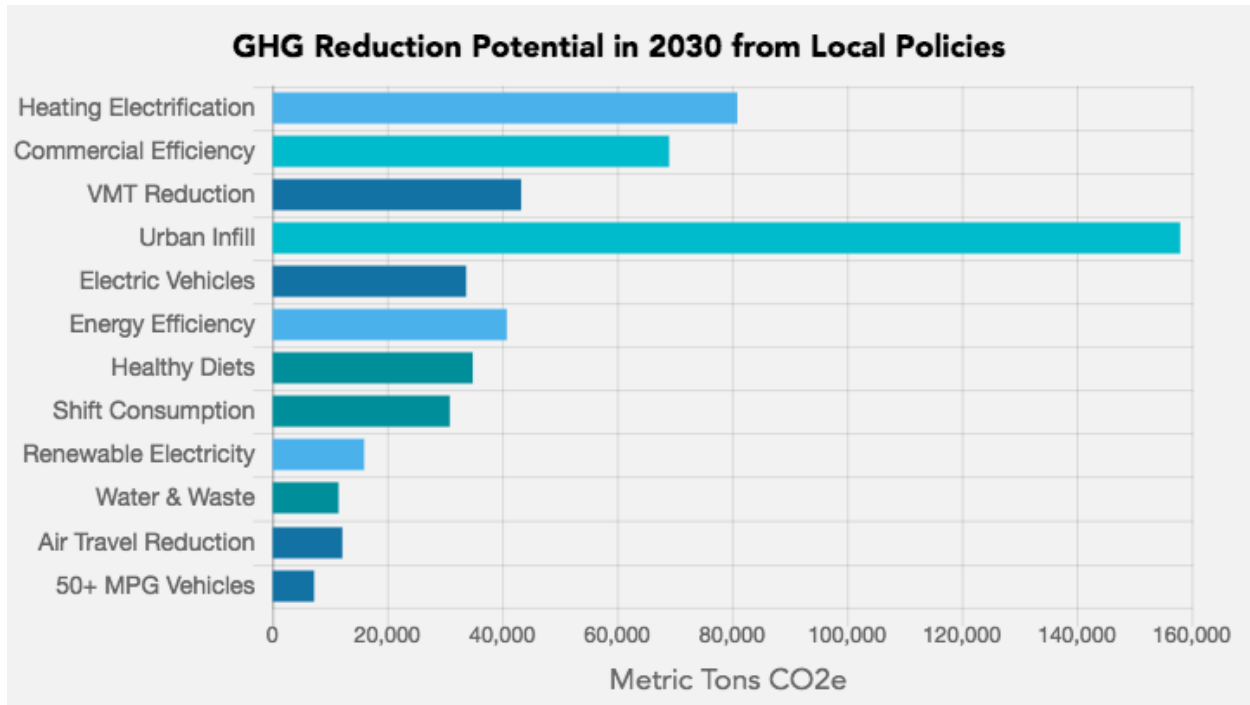

**CONTACT PERSON(S):**

Lori Droste, 510-981-7180

**ATTACHMENTS:**

Minneapolis Plan:

[https://minneapolis2040.com/media/1428/pdf\\_minneapolis2040\\_with\\_appendices.pdf](https://minneapolis2040.com/media/1428/pdf_minneapolis2040_with_appendices.pdf)

Seattle' Plan:

<http://www.seattle.gov/Documents/Departments/SeattlePlanningCommission/SPCNeighborhoodsForAllFINAL121318digital.pdf>

## **Berkeleyside**

### **Opinion: We can design our way out of Berkeley's housing crisis with 'missing middle' buildings**

*A Berkeley architect argues that Berkeley should build more small-scale, multi-unit buildings such as duplexes, bungalow courts, fourplexes, and small mansion apartments.*

By Daniel Parolek

Dec. 19, 2017

Berkeley's housing problems have gone national recently, as The New York Times' Conor Dougherty highlighted in a thought-provoking article, "The Great American Single-Family Home Problem." Dougherty examines the conflicting interests and regulations that threatened to halt the development of one lot on Haskell Street, and shows how those conflicting forces are contributing to the affordable housing crisis we are seeing in our state – and across the country.

As an architect and urban designer based in Berkeley for the past 20 years, I agree that California municipalities have an urgent need to deliver more housing. That said, just delivering more housing is not enough. We need to think about how this housing reinforces a high quality built environment and how to provide a range of housing for all segments of the market, including moderate and low-income households. More small-scale, multi-unit buildings such as duplexes, bungalow courts, fourplexes, and small mansion apartments, or what I call "Missing Middle Housing," should be a key focus of that housing.

Unfortunately, the design proposed for the Haskell Street site in Berkeley does not deliver on reinforcing a high quality built environment or affordability and, as the NYT article makes clear, does not deliver on any level of affordability. There are better design solutions that deliver a more compatible form, that have more and a broader range of housing units, and that can be more effective at building local support for this and similar infill projects.

For example, the 50' x 150' lot at 310 Haskell Street is big enough to accommodate a traditional fourplex, with two units down and two units above in a building that is the scale of a house (see image attached from our Missing Middle research). The units would typically be between 750-900 square feet each. An important characteristic of this housing type is that they do not go deeper onto the lot than a traditional house, thus eliminating the concern about privacy and shading and providing high-quality outdoor living spaces. These fourplex housing types exist all over Berkeley and are often successfully integrated onto blocks with single-family homes.

So how do we get there? Berkeley and most cities across the country need to sharpen their pencils on their outdated zoning codes, first to remove barriers for better solutions and secondly, to create a set of regulations that ensure that inappropriate design solutions like the one proposed for Haskell Street or even worse are not allowed on these sites. Lower densities do not equal better design solutions and higher densities do not need to mean larger or more buildings. This is a delicate balance that few zoning codes achieve and few code writers fully

understand.

We also need to change the way we communicate about housing needs in our communities. If we are using George Lakoff's rules for effective communication we would never go into a housing conversation with a community and use terms like "increasing density, adding multi-family, or upzoning a neighborhood." I can think of few neighborhoods that would feel good about saying yes to any of those options if they were framed in that way, but which can mostly get on board with thinking about aging within a neighborhood, or ensuring their kids or grandkids can afford to move back to the city they grew up in. Beginning this conversation by simply showing photographic and/or local existing documented examples of good Missing Middle housing types often disarms this conversation and leads to more fruitful results.

Berkeley's challenges related to housing are not going to go away anytime soon. We need to thoughtfully remove barriers to enable a broad range of solutions like the fourplex that have been a core part of choices provided in our communities already and learn how to effectively build consensus and support for good design solutions such as Missing Middle housing types.

*Daniel Parolek is an architect and urban designer who co-authored the book "Form-Based Codes," coined the term Missing Middle Housing ([www.missingmiddlehousing.com](http://www.missingmiddlehousing.com)) and speaks and consults nationally on these topics.*



Lori Droste  
Councilmember, District 8

### **Action Calendar**

April 23, 2019

*(Continued from April 2, 2019)*

To: Honorable Mayor and Members of City Council

From: Councilmember Lori Droste, Councilmember Rashi Kesarwani, and Councilmember Ben Bartlett

Subject: Adopt a Spot Initiative

### **Recommendation**

Refer to the Public Works Commission and Parks and Waterfront Commission to develop an Adopt A Spot initiative; specifically outlining potential environmental benefits, program costs, staffing.

#### *Rationale:*

- *Adopt a Spot programs enable a network of volunteer residents to assist in city maintenance and clean up efforts which have great impact using minimal City staff/funding.*
- *Vision 2050 will include stormwater and watershed management goals, both of which this program would support.*

### **Background**

The City of Berkeley currently maintains an Adopt A Drain program. An Adopt A Spot program would utilize volunteers to assist with activities including, but not limited to, storm drain maintenance, street beautification, trash cleanup, gardening initiatives, etc.

*The City of Oakland Adopt a Spot Program*

The City of Oakland coordinates hundreds of volunteers to clean, green, maintain, and beautify public spaces (such as parks, libraries, creeks) and infrastructure (such as signs, storm drains, litter containers, utility boxes and poles, street tree wells, and trees). Managed by the Environmental Stewardship Team within the Oakland Public Works Department, this volunteer program has been active throughout the city for over thirty years. The volunteer program supports community cleanups throughout the year, annual city-wide cleanups for Earth Day, Creek to Bay Day, MLK Day of Service, and “Adopt a Spot,” an ongoing volunteer stewardship program that includes a growing list of over 2,000 Oakland “spots.”

Volunteers contribute over 100,000 hours each year, contributing to a wide range of environmental sustainability impacts such as pollution cleanup and prevention; wildlife habitat protection, enhancement, and restoration; and stormwater management. Volunteerism also strengthens communities by connecting people to each other, to their neighborhoods, and to their environment. These benefits enhance Oakland’s economy, safety, and livability,

The City of Oakland Public Works’ *Adopt a Drain* program supports volunteer efforts to keep storm drain inlets clean and clear of trash and debris. Clear and clean inlets keep water flowing and ensure “only rain down the drain,” which is especially helpful during storm events when blocked storm drains can back up and cause flooding. Year-round storm drain maintenance helps intercept trash before it enters the storm drains and connecting creeks and water bodies.

The City of Oakland provides support for Adopt a Drain volunteers through instruction, tools and supplies, assistance with debris pickups, and notification of impending storm events.

Over 1,000 of Oakland’s approximately 12,000 storm drains have been adopted. The more than 800 Adopt a Drain volunteers greatly supplement the capacity of the twenty City staff servicing the storm drain system, with its more than 1,200 storm drains, 370 miles of drain pipe, seven pump stations and 40 miles of creeks. Volunteers can quickly and preemptively provide basic maintenance on drains and can have a far more extensive and immediate reach across the city than staff during storm and flooding emergencies.

Oakland uses a map interface at [www.AdoptaDrainOakland.com](http://www.AdoptaDrainOakland.com) for depicting the City’s storm drain inlets to the public for possible adoption. This easy to use interface has helped spur new volunteer registrations. Social media, word-of-mouth, and timely news



coverage prior to and during storm events has also contributed to volunteer registrations. More information is available at [www.oaklandadoptaspot.org](http://www.oaklandadoptaspot.org).

**Environmental Sustainability**

Helps Berkeley fulfill Watershed and Stormwater Management Plan goals.

**Financial Implications**

Staff time to coordinate volunteers and provide technical assistance.

**Contact**

Councilmember Lori Droste 510-981-7180





Office of the City Manager

ACTION CALENDAR

April 23, 2019

To: Honorable Mayor and Members of the City Council

From: Dee Williams-Ridley, City Manager

Submitted by: Mark Numainville, City Clerk  
Farimah Brown, City Attorney

Subject: Referral Response: Updated Policy for Emergency Standby Officers for the Mayor and Councilmembers

RECOMMENDATION

Adopt a Resolution updating the selection process and criteria for the appointment of Standby Officers for the Mayor and each Councilmember to serve in the event the elected official is unavailable during an emergency, and rescinding Resolution No. 57,906-N.S.

POLICY COMMITTEE RECOMMENDATION

On March 11, 2019, the Agenda and Rules Committee adopted the following action: M/S/C (Arreguin/Wengraf) to send the item to the full Council with a Positive Recommendation. Vote: All Ayes.

FISCAL IMPACTS OF RECOMMENDATION

None.

CURRENT SITUATION AND ITS EFFECTS

The item originally appeared on the February 19, 2018 agenda. The City Council referred the item to the Agenda and Rules Committee for further analysis. On March 11, 2019 the committee voted to send to Council with edits to add a requirement for filing Form 700, revise the city government experience requirement, and revise the due date for nominations.

This report responds to a short term referral that originally appeared on the agenda of the September 13, 2018 Council meeting and was sponsored by Councilmember Wengraf, Mayor Arreguin, and Councilmember Hahn.

The referral requested that the City Manager consider the following suggestions for eligibility requirements and qualifications for Emergency Standby Officers and return to Council within 90 days with recommendations.

- Trainings in roles and responsibilities to serve as a standby officer possibly including: ethics and workplace harassment.

- City government experience
- Council District residency
- Require standby officers to meet the same qualifications, including restrictions on conflict of interest, as required in the City Charter for City Councilmembers.
- In addition, consider requiring Councilmembers to nominate three people in a single action.

The proposed policy in the attached resolution incorporates all of these suggestions except for the requirement for Council District residency. The requirement for district residency was not included as it would conflict with the state codes governing standby officers. The code allows for standby officers to be residents of another political subdivision. The reason for this is that a severe local emergency event that results in the unavailability of a Councilmember will have a higher likelihood of impacting the availability of a standby officer if that standby officer is from the same immediate area.

***California Government Code Section 8639***

*The qualifications of each standby officer should be carefully investigated, and the governing body may request the Director of Emergency Services to aid in the investigation of any prospective appointee. No examination or investigation shall be made without the consent of the prospective appointee.*

*Consideration shall be given to places of residence and work, so that for each office for which standby officers are appointed there shall be the greatest probability of survivorship. Standby officers may be residents or officers of a political subdivision other than that to which they are appointed as standby officers.*

The policy includes trainings in the same areas as trainings that Councilmembers receive: AB1234 (Ethics), Harassment prevention, Brown Act, Conflict of Interest, and roles and responsibilities in an emergency.

The policy also now requires that the standby officer be 18 years of age or older and a registered voter.

If the updated policy is adopted by the Council, the City Clerk Department, City Attorney's Office, and the Human Resources Department will coordinate to ensure that the eligibility criteria are met and that the background checks and trainings are completed.

Previously approved standby officers will be required to meet all training requirements of the updated policy.

### BACKGROUND

On March 14, 1995, the Council adopted Resolution No. 57,906-N.S., designating a procedure for the selection of Standby Officers for City Councilmembers in the event of an emergency. This procedure is part of the City's emergency preparedness planning and ensures that in the case of a disaster or other catastrophic emergency causing the unavailability of one or more members of the Council (or Standby Officers where a Councilmember is unavailable), government can continue to function. Under state law, a Councilmember or Standby Officer is "unavailable" when he or she is "either killed, missing, or so seriously injured as to be unable to attend meetings and otherwise perform his [or her] duties." (Govt Code § 8636.)

### ENVIRONMENTAL SUSTAINABILITY

There are no identifiable environmental effects or opportunities associated with the subject of this report.

### RATIONALE FOR RECOMMENDATION

This recommendation is in response to a referral from the City Council. Standby Officers are an essential part of any fully developed emergency plan in order maintain the continuity of government in an emergency.

### CONTACT PERSON

Mark Numainville, City Clerk, 981-6900  
Farimah Brown, City Attorney, 981-6998

### Attachments:

1: Resolution

## RESOLUTION NO. ##,###-N.S.

## DESIGNATING PROCEDURE FOR SELECTION OF STANDBY OFFICERS FOR CITY COUNCILMEMBERS IN THE EVENT OF A DISASTER AND RESCINDING RESOLUTION NO. 57,906-N.S.

WHEREAS, the California Emergency Services Act, Government Code sections 8550, et seq., which sets out basic state procedures for declaration of emergency, includes a section "Preservation of Local Government," which provides various methods of insuring that in the case of a catastrophic emergency, in which it is possible that members of a governing body become unavailable, government can be reconstituted and continue until regular elections can be held; and

WHEREAS, the Act envisions reconstitution of the governing body through the predesignation of three standby officers for each Councilmember which may be appointed by the City Council, and who may substitute for the elected official if he or she were unavailable; and

WHEREAS, the Act provides some procedures but does not spell out the method of selection and ratification in all respects; and

WHEREAS, the Act further provides that the qualifications of each standby officer should be carefully investigated but does not mandate what the qualifications should be.

NOW THEREFORE BE IT RESOLVED by the Council of the City of Berkeley that the following procedure for appointment of Standby officers is adopted:

1. No person who has been convicted of the crimes of bribery, malfeasance in office, violation of Government Code Section 1090 or the Political Reform Act shall be eligible to be a Standby Officer.

2. Each Councilmember shall identify three potential standby officers for that Councilmember, shall obtain written consent for each person being named, shall designate each proposed officer as No. 1, 2 or 3, and shall submit the name of each person to the City Manager by July 15, 2019.

3. The initial nomination of all three standby officers must be done in a single action.

4. The City Manager shall investigate the qualification of each proposed standby officer, and shall submit the names of those proposed standby officers as to whom the investigation verified their qualifications to the City Council.

5. The names of the proposed, investigated and approved standby officers shall be submitted to the City Council as a whole for final approval.

6. Standby officers must be 18 years of age or older and a registered voter, and complete the following trainings within six months of his or her approval by the City Council:

- a. Training in roles and responsibilities to serve as a standby officer.
- b. Training in Ethics as mandated by AB 1234
- c. Training in Conflict of Interest restrictions and disclosures
- d. Training in the requirements of the Brown Act
- e. Training in Workplace Harassment Prevention.

7. Standby officers must file Form 700 Statement of Economic Interest at the time they are nominated.

8. The Mayor and Councilmembers shall nominate persons with experience in city government and/or disaster preparedness.

BE IT FURTHER RESOLVED that Resolution No. 57,906-N.S. is hereby rescinded.





Councilmember Ben Bartlett  
 City of Berkeley, District 3  
 2180 Milvia Street, 5<sup>th</sup> Floor  
 Berkeley, CA 94704  
 PHONE 510-981-7130  
 EMAIL: [bbartlett@cityofberkeley.info](mailto:bbartlett@cityofberkeley.info)

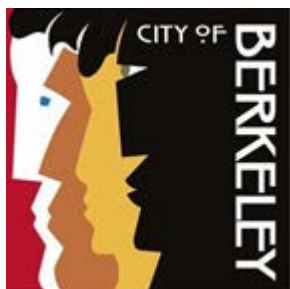

CONSENT CALENDAR  
 April 23rd, 2019

**To:** Honorable Mayor and Members of the City Council  
**From:** Paid Family Leave Subcommittee; Councilmember Bartlett, Hahn, Harrison, and Davila  
**Subject:** **Berkeley Paid Family Leave Policy**

TITLE

Paid Family Leave Policy in Berkeley to Supplement California Paid Family Leave Program

RECOMMENDATION

That the City Council adopt this policy and refer to the City Manager and City Attorney to amend the proposed ordinance based on the recommendations of the Paid Family Leave (PFL) Subcommittee and to conform to legal and code consistency requirements. Currently, California PFL compensates employees for only 60% to 70% of their regular salary. Berkeley PFL will obligate covered employers to supplement this compensation so that their covered employees can receive up to 100% of their gross weekly salary when taking time off, up to the State maximum weekly benefit amount:

- 1) To bond with a new child entering their life either by birth, adoption, or foster care placement
- 2) To care for an ailing family member including child, parent, sibling, spouse, grandparent, parent-in-law or domestic partner

Berkeley PFL will cover employees of:

- 1) Companies and organizations with more than 150 employees worldwide
- 2) Employers owning five or more owner-controlled franchise businesses worldwide
- 3) City of Berkeley non-benefited employees

These Employees at these will be eligible to utilize Berkeley PFL after 180 days of employment, and any employees utilizing Berkeley PFL will be protected from retaliation by their employer.

Two years after the effective date of the Berkeley PFL ordinance, staff shall prepare a report on the success and/or challenges of implementing Berkeley PFL and considering changes to the ordinance, including the possibility of lowering the threshold of applicability for employers, lowering the number of days before an employee is covered, conformance with new State law, if any, and any other changes staff may recommend.

In addition, the following specific changes are recommended:

Legislative Findings. REMOVE LEGISLATIVE FINDINGS FROM ORDINANCE, unless city attorney feels limited findings or purpose statement is required.

- Definitions: Look at definitions that are generic to BMC and make sure they conform to existing code, or remove them.

- Section .030 (B)(d)(i). In middle of paragraph, “for example” elements, remove from ordinance and include in implementation guidelines.
- .030(B)(d)(ii) “for example...” element, remove from ordinance and include in implementation guidelines.
- 030(B)(4): “unless covered employer...reason,” ADD “or reasons” after reason.
- 030(B)(5): “Unused Vacation Leave” change to “Unused Accrued Leave Benefit” whenever you see the first phrase replace it with the second throughout the document
- 060(D) change reason to “reason or reasons”...Parallel to 030(B)(4)
- 070(A) strike everything after the 2<sup>nd</sup> sentence.
- 9.90.080

Refer to the City Manager to review in particular implementation and enforcement provisions to ensure conformity with existing implementation and enforcement of similar measures, except that the terms under 9.90.080(A)(1)(a) and (b) and (c) the fines shall remain as stated in the ordinance as proposed. Under A(2) the city may pursue administrative remedies in accordance with Section 1.28. Strike the remainder of 0802

Short term referral to direct City Manager to return within 90 days staffing implications for launch phase and long term administration of Berkeley PFL.

### CURRENT SITUATION

The United States is the only industrialized nation that does not guarantee paid leave for new parents. Currently, California State law only replaces 60% to 70% of income for 6 weeks for parental leave, funded entirely by employee contributions. Numerous studies have linked longer parental leave to greater bonds with newborns, foster children, and adopted children, displaying a multitude of beneficial effects for both the child and the parents<sup>1</sup>.

The United States also has no legislation guaranteeing employees paid leave when taking care of ailing family members. This forces a balancing act on workers of maintaining their financial stability and caring for a family member such as a parent. Under current laws, workers must take sick time, vacation, or unpaid time off to care for a family member, adding stress and uncertainty to their own lives.

### BACKGROUND

Paid Family Leave assists and sometimes enables parents to bond with newborns. There is a multitude of research detailing how longer periods of leave from work lead to better health outcomes for newborns. A report published in the Journal of Delivery Science and Innovation in 2016 reviewed 20 years of data on the association between Paid Family Leave and health outcomes. Among the findings include:

---

<sup>1</sup> [http://libres.uncg.edu/ir/uncg/f/C\\_Ruhm\\_Parental\\_2000.pdf](http://libres.uncg.edu/ir/uncg/f/C_Ruhm_Parental_2000.pdf),  
[https://moneydotcomvip.files.wordpress.com/2015/01/hipfactsheet\\_2011.pdf](https://moneydotcomvip.files.wordpress.com/2015/01/hipfactsheet_2011.pdf)

“The United States has an infant mortality rate at least twice that of Sweden. About 39% of US excess infant mortality when compared to Sweden is due to our high preterm infant mortality rate. Lacking antenatal leave has been associated with a three-fold increase in risk of preterm delivery. Working longer into pregnancy has also been linked to delivery complications. Taking leave before the end of pregnancy has benefits to birthweight approaching the same magnitude as the harms seen in smoking during pregnancy. Examining 18 countries over more than 30 years, Tanaka found a statistically significant correlation between lower birthweight and lack of access to job-protected paid parental leave. Stearns found the treatment effects for even short maternity leaves meant a 12% reduction in LBW deliveries to mothers in the five American states with TDI programs. Rossin, examining the effects of unpaid leave for women believed most likely to take such leave, found a 47% reduction in the likelihood an infant born to one of these women died of an ‘ill-defined’ cause. SIDS, one of several causes of infant mortality in the ‘ill-defined’ category, makes up 21% of American infant mortality alone.”<sup>2</sup>

A 2012 survey by the US Department of Labor found that the main reason employees in the United States do not take unpaid leave under the federal Family Medical Leave Act is that they cannot afford to take it<sup>3</sup>. Further, studies show that low-wage workers in particular would benefit from expanded paid family leave policies. Giving employees the freedom to take leave has important effects on quality of life, especially for new mothers. Babies whose mothers work during the first three months of the baby’s life are less likely to be breastfed, taken to the doctor for well-baby visits, or be up to-date on immunizations<sup>4</sup>. According to a 2015 study, rates of breastfeeding through infancy in California increased by 10%-20% after California developed its Paid Family Leave program, which entitles employees to receive partial wage replacement while on leave<sup>5</sup>.

A Paid Family Leave program will also benefit caretakers and ailing family members. Giving employees the freedom to take leave to care for a sick family member has enormous implications for a large portion of our population. A 2012 survey of employees in the United States showed that 1.6% of all workers faced an unmet need for leave due to a parent’s, spouse’s, or child’s health condition<sup>6</sup>. The National Alliance for Caregiving (NAC) reports that there are at least 43.5 million unpaid family caregivers in the United States and that family caregivers provide an average of 20 hours of care per week. Moreover, caregiving often isn’t limited to a few months, or even a year — in fact, caregiving lasts an average of almost five years and 70% of all caregivers are working while caring for a loved one. Caregiving can cause significant financial, physical and emotional strain. NAC reports nearly 7 in 10 caregivers report having to make work accommodations while they are providing care to a loved one. Of caregivers who take time off to fulfill their responsibilities at home, 48% report losing income<sup>7</sup>. Of caregivers who leave the workforce, half (52%) said they did so because their jobs did not allow the flexibility they needed to work and provide elder care<sup>8</sup>. And caregiving takes more than a financial toll – It is widely documented that caregivers experience high levels of stress, depression, and suffer from higher rates of chronic disease, and diminished immune response. As our population ages and caregiving needs increase, paid leave will be even more critical to helping ensure working people can take care of their loved ones without risking their economic security.

<sup>2</sup> <http://www.nationalpartnership.org/our-work/workplace/paid-leave-resources.html#effect>

<sup>3</sup> <https://www.dol.gov/asp/evaluation/fmla/fmla-2012-technical-report.pdf>

<sup>4</sup> <http://cepr.net/documents/publications/paid-family-leave-1-2011.pdf>

<sup>5</sup> <https://www.ncbi.nlm.nih.gov/pubmed/24508006>

<sup>6</sup> <https://www.dol.gov/asp/evaluation/fmla/FMLA-2012-Technical-Report.pdf>

<sup>7</sup> [http://familiesandwork.org/site/research/reports/elder\\_care.pdf](http://familiesandwork.org/site/research/reports/elder_care.pdf)

<sup>8</sup> <http://www.familiesandwork.org/downloads/2014-Older-Adult-Caregiver-Study.pdf>

REVIEW OF EXISTING PLANS, PROGRAMS, POLICIES, LAWS

Currently, the State of California offers a 6 week Paid Family Leave plan that covers 60% to 70% of an employee's compensation based on their income. This amount is calculated using the highest quarterly earning for the employee during the previous year. An employee is eligible for California PFL only if they have paid more than \$300 to California Disability Insurance in the previous 12 months. California PFL covers the birth of a child or care for a seriously ill family member. California PFL lasts for a maximum of 6 weeks, and allows an employer to require the employee to use vacation or paid time off for 2 weeks before the benefits of California PFL begin.

ACTIONS/ALTERNATIVES CONSIDERED

Paid Family Leave policies from Washington State and San Francisco were both considered.

CONSULTATION/OUTREACH OVERVIEW AND RESULTS

The Ad-Hoc Subcommittee on Paid Family Leave has received proposals from the Commission on the Status of Women and the Commission on Labor.

RATIONALE FOR RECOMMENDATION

The goal is to ensure that concern over loss of income does not preclude Berkeley employees from bonding with their new child or taking care of a seriously ill family member. This item complements California's Paid Family Leave law to ensure that qualified employees can receive 100% compensation when taking paid family leave. This will provide Berkeley residents with more time to bond with their children or care for people close to them. We expect this to alleviate a number of social ailments.

FISCAL IMPACTS

Staff or contractor costs for the launch and ongoing administration of the program, for Outreach and education, enforcement, administration and analysis. Cost of covering currently unbenefitted city employees shall also be assessed, balanced against potential improvements in employee retention due to the added benefit.

ENVIRONMENTAL SUSTAINABILITY

No negative impact.

CONTACT PERSON

Councilmember Ben Bartlett: 510-981-7130  
Matt Napoli: 510-981-7131

ATTACHMENTS/SUPPORTING MATERIALS



Kate Harrison  
Councilmember District 4

ACTION CALENDAR  
April 23, 2019

To: Honorable Mayor and Members of the City Council  
 From: Councilmember Harrison and Mayor Arreguín  
 Subject: Allocate \$400,000 from the Street and Open Space Improvement Fund for the Design and Construction of a Protected Milvia Bikeway Pilot Project between University Avenue and Allston Way

RECOMMENDATION

Adopt a Resolution allocating \$400,000 from the Street and Open Space Improvement Fund (SOSIF) to design and construct a protected Milvia Bikeway pilot project between University Avenue and Allston Street.

BACKGROUND

The Department of Public Works is currently pursuing a 0.7 mile Milvia Street bikeway project with initial funding from a Measure B sales tax grant from the Alameda County Transportation Commission (Alameda CTC). This bikeway is a priority in the City's Bicycle Plan.<sup>1</sup> The project will make bicycle and pedestrian safety improvements that align with the city's bicycle, pedestrian, climate, and Vision Zero goals. Staff estimate that permanent upgrades for the entire bikeway extending between Hearst Avenue and Blake Street will cost approximately: \$350,000 to design, \$273,000 for consultant costs and a total of \$4,200,000 to build. The earliest the entire bikeway could be completed is in 2022.

This Resolution empowers the Council to accelerate the project by allocating SOSIF funding to the project, for design and construction of a critical pilot portion between University Avenue and Allston Way in the near-term. The intersection at Milvia and University has the highest collision rate for walking and cycling in the City and is tied with Milvia and Dwight for the highest number collisions involving cyclists.<sup>2</sup>

---

<sup>1</sup> Berkeley Bicycle Plan 2017, Berkeley Transportation Division, May 2, 2017, <https://www.cityofberkeley.info/berkeleybikeplan/>; See also, Milvia Street Bikeway Project Public Open House, City of Berkeley, January 30, 2019, [https://www.cityofberkeley.info/uploadedFiles/Public\\_Works/Level\\_3\\_-\\_Transportation/18055%20Berkeley%20Milvia%20Public%20Workshop%20Exhibits%202019201%20email.pdf](https://www.cityofberkeley.info/uploadedFiles/Public_Works/Level_3_-_Transportation/18055%20Berkeley%20Milvia%20Public%20Workshop%20Exhibits%202019201%20email.pdf), p. 2.

<sup>2</sup> *Id.*, p. 6.

The SOSIF is a depository for the in-lieu fees paid by developers for the “timely development of open space improvements that will serve the needs of both project residents and other people living in and using the downtown.” The Department reports that the SOSIF fund has a projected gross fund balance of \$1,230,951 in FY 2019 and \$432,592 in FY 2020. Council specified that these fees are to be used for projects in the 2012 Downtown Streets and Open Space Improvement Plan (SOSIP).<sup>3</sup> The Milvia Bikeway is designated as a project in the SOSIP.<sup>4</sup>

Public Works presented the bikeway project in both near and long-term phases spanning 2019-2022. Preliminary conversations (subject to change) with the community, impacted businesses and staff suggest that the City’s *Near-Term Option 2*, featuring one-way protected bicycle lanes in each travel direction and one-way southbound vehicle traffic from University Avenue to Addison Street, and one-way cycle tracks with two-way vehicle traffic between Addison Street and Allston Way may be a feasible near-term option for a Milvia cycle track pilot.<sup>5</sup> Berkeley Transportation Division staff indicate that pilot project construction could begin as early as spring 2020. In addition, staff would pursue the pilot project in coordination with an ongoing traffic study of the Milvia-University intersection and a PG&E electrification infrastructure upgrade project.

---

<sup>3</sup> Open Space In-Lieu Fee for New Downtown Buildings, Department of Public Works, June 13, 2017, [https://www.cityofberkeley.info/Clerk/City\\_Council/2017/06\\_June/Documents/2017-06-13\\_Item\\_56\\_Open\\_Space\\_In-Lieu\\_Fee.aspx](https://www.cityofberkeley.info/Clerk/City_Council/2017/06_June/Documents/2017-06-13_Item_56_Open_Space_In-Lieu_Fee.aspx).

<sup>4</sup> Streets and Open Space Improvement Plan Chapter 6: Bicycle Networks and Facilities, Department of Planning & Development, [https://www.cityofberkeley.info/uploadedFiles/Planning\\_and\\_Development/Level\\_3\\_-\\_DAP/Chapter%206%20Bicycle%20Networks%20and%20Facilities.pdf](https://www.cityofberkeley.info/uploadedFiles/Planning_and_Development/Level_3_-_DAP/Chapter%206%20Bicycle%20Networks%20and%20Facilities.pdf).

<sup>5</sup> “Milvia Street Bikeway Project Public Open House,” p. 6.

Allocate \$400,000 from the Street and Open Space Improvement Fund for the Design and Construction of a Protected Milvia Bikeway Pilot Project between University Avenue and Allston Way

ACTION CALENDAR  
April 23, 2019

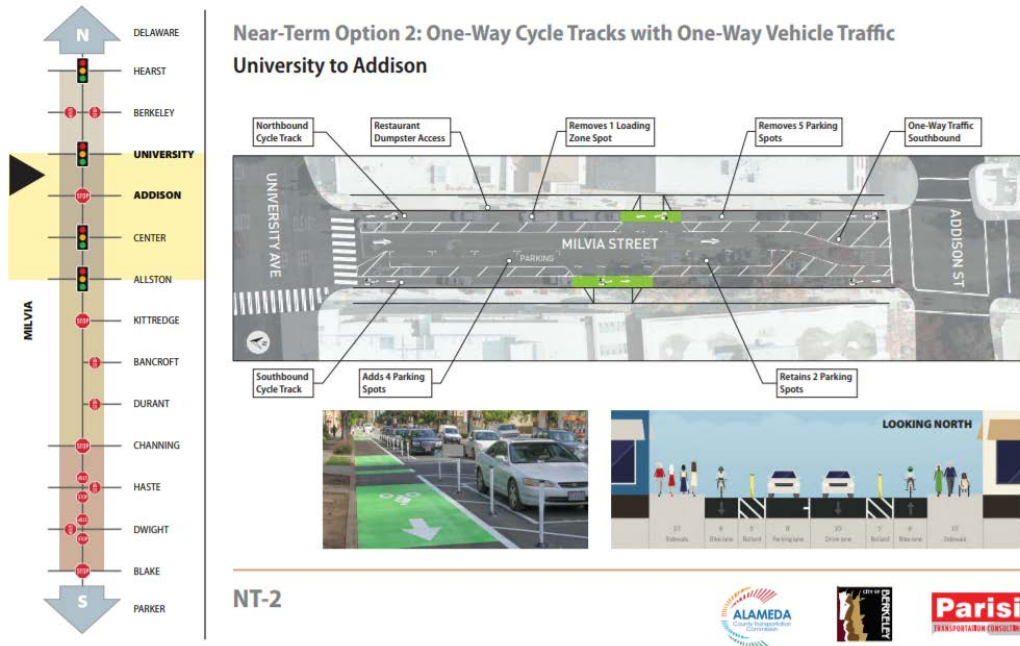

Figure 16

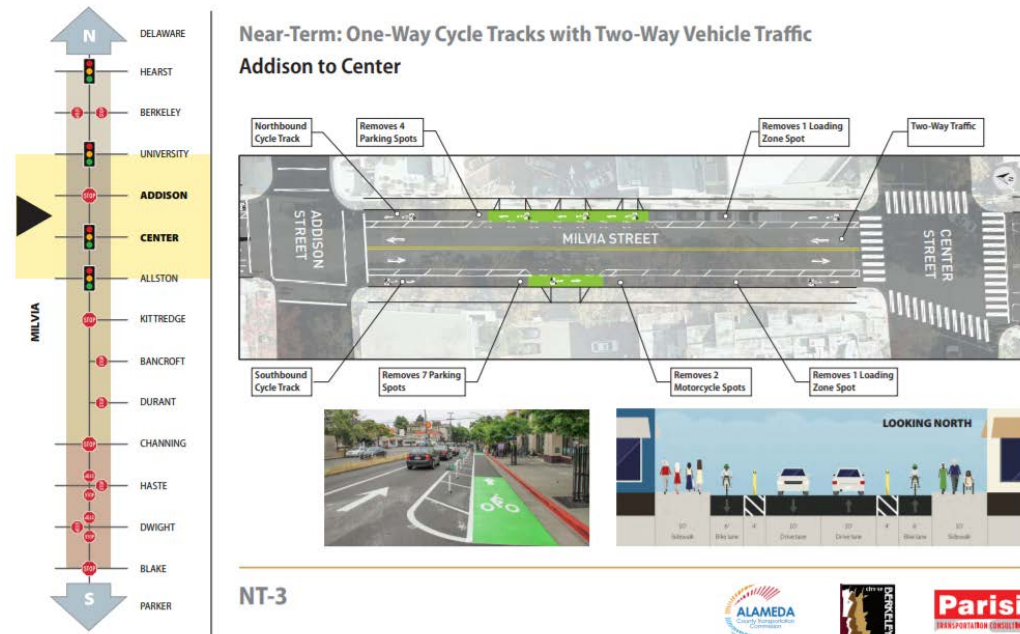

Figure 27

<sup>6</sup> *Id.*, p. 10.

<sup>7</sup> *Id.*, p. 11.

Allocate \$400,000 from the Street and Open Space Improvement Fund for the Design and Construction of a Protected Milvia Bikeway Pilot Project between University Avenue and Allston Way

ACTION CALENDAR  
April 23, 2019

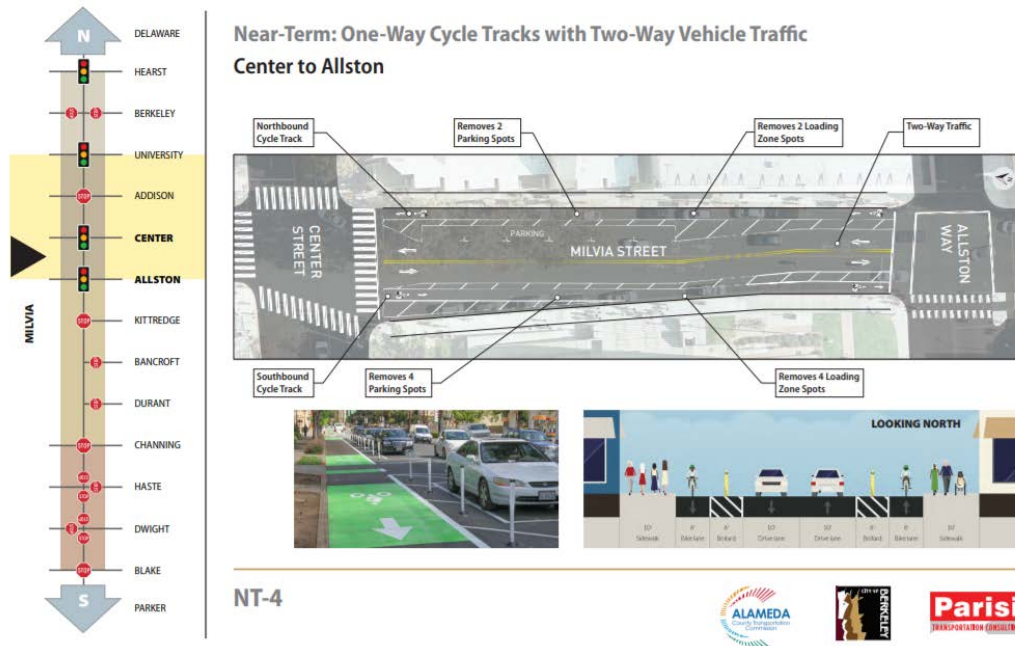

Figure 3<sup>8</sup>

It is in the public interest to allocate SOSIF funds for the near-term bikeway project, which is prominently featured in the 2012 SOSIP and is critical to the City’s health, safety and climate goals.

According to the City’s Transportation Division, Berkeley has the highest rate of bicycling to work in the U.S. of cities with greater than 100,000 residents. Berkeley’s Downtown area is the heart of Berkeley’s culture, economy, government, and education system. The Downtown’s Milvia bikeway is the city’s primary north-south bikeway, featuring intersections through which 400-500 cyclists pass during daily peak periods.<sup>9</sup>

Since 1971, the City of Berkeley has considered and planned to make Milvia Street safe and attractive for people riding bikes through Downtown. The bikeway was consistently referenced in the City Bicycle Plans (1999 and 2005), Streets and Open Space Plan (2012), and the Downtown Berkeley Area Plan (2012).<sup>10</sup> Unfortunately, today the Milvia bike corridor consists of a combination of rudimentary bike boulevards and bike lanes that fail to adequately protect cyclists.

<sup>8</sup> *Id.*, p. 12.

<sup>9</sup> Milvia Bikeway Project, Transportation Division, [https://www.cityofberkeley.info/Planning\\_and\\_Development/Downtown\\_Area\\_Plan/Streets\\_and\\_Open\\_Space\\_Improvement\\_Plan.aspx](https://www.cityofberkeley.info/Planning_and_Development/Downtown_Area_Plan/Streets_and_Open_Space_Improvement_Plan.aspx).

<sup>10</sup> “Milvia Street Bikeway Project Public Open House,” p. 3-8.



City bikeway research suggests that that individuals who may otherwise cycle across the Downtown are hesitant to do so because the route is deemed unsafe. The Department of Public Works found that the existing bike lanes and boulevards on Milvia feature the highest number of cycling collisions of any Berkeley bikeway. Furthermore, bicyclists consistently report that Milvia is one of the “most stressful” corridors to navigate and as a result are only suitable for the most “traffic-tolerant” cyclists. The Berkeley Strategic Transportation Plan (2015) and Bicycle Plan (2012) recommend replacing the existing Class III Bicycle Boulevard and Class II bicycle lanes on Milvia with a Class IV cycle track. Some 72% residents surveyed in September 2018 supported such a protected bikeway across Milvia Street.<sup>11</sup>

Beyond the basic health and safety necessity of this infrastructure, the City has a strong environmental interest in building infrastructure that offsets greenhouse gas emitting vehicles with zero carbon and low-carbon modes of transportation. The Energy Commission found in its 2019 Fossil Free report that expanding bicycle transportation infrastructure will be critical to addressing transportation emissions, which is the largest sector of Berkeley’s greenhouse gas emissions.<sup>12</sup> Further, transportation emissions in Berkeley have risen in recent years, unlike other emission sectors.<sup>13</sup>

### FINANCIAL IMPLICATIONS

This resolution results in an expenditure of \$400,000 in SOSIF fees for the design and construction of a pilot that is designated as a broader SOSIP project. The Department of Public Works projects a \$432,592 gross fund balance for FY 2020.

### ENVIRONMENTAL SUSTAINABILITY

Completing the Milvia Bikeway project is directly in line with the Climate Action Plan and subsequent plans as it has the potential to lower greenhouse gas emissions by encouraging residents to use bicycles and other low-carbon methods of transportation.

### CONTACT PERSON

Councilmember Kate Harrison, Council District 4, 510-981-7140

---

<sup>11</sup> *Id.*

<sup>12</sup> Fossil Free Berkeley Report, Berkeley Energy Commission, January 23, 2019, [https://www.cityofberkeley.info/uploadedFiles/Planning\\_and\\_Development/Level\\_3\\_-\\_Commissions/Commission\\_for\\_Energy/EC2019-1-23\\_Item%205\\_Fossil%20Fuel%20Subcommittee%20Report.pdf.pdf](https://www.cityofberkeley.info/uploadedFiles/Planning_and_Development/Level_3_-_Commissions/Commission_for_Energy/EC2019-1-23_Item%205_Fossil%20Fuel%20Subcommittee%20Report.pdf.pdf).

<sup>13</sup> 2018 Berkeley Climate Action Plan Update, Office of Energy and Sustainable Development, December 6, 2018, [https://www.cityofberkeley.info/Clerk/City\\_Council/2018/12\\_Dec/Documents/2018-12-06\\_WS\\_Item\\_01\\_Climate\\_Action\\_Plan\\_Update\\_pdf.aspx](https://www.cityofberkeley.info/Clerk/City_Council/2018/12_Dec/Documents/2018-12-06_WS_Item_01_Climate_Action_Plan_Update_pdf.aspx), p. 20.

RESOLUTION NO. ##,###-N.S.

ALLOCATE \$400,000 FROM THE STREET AND OPEN SPACE IMPROVEMENT FUND FOR THE DESIGN AND CONSTRUCTION OF A MILVIA BIKEWAY PILOT PROJECT BETWEEN UNIVERSITY AVENUE AND ALLSTON WAY

WHEREAS, Berkeley has the highest rate of bicycling to work in the United States among cities with over 100,000 residents, and the Downtown Milvia bike corridor is the City's primary north-south bikeway; and

WHEREAS, Downtown Berkeley is the heart of Berkeley's culture, economy, government, and education system; and

WHEREAS, the City of Berkeley has considered Milvia Bikeway improvements since 1971, including references in the City Bicycle Plans (1999 and 2005), Streets and Open Space Plan (2012), and the Downtown Berkeley Area Plan (2012); and

WHEREAS, according to State data, the existing Milvia Street has the highest number of cycling collisions of any Berkeley bikeway; and

WHEREAS, today, the Milvia Street bikeway consists of a combination of rudimentary bike boulevards and bike lanes that fail to adequately protect cyclists; and

WHEREAS, the Berkeley Strategic Transportation Plan (2015) and Bicycle Plan (2012) recommend replacing the existing Class III Bicycle Boulevard and Class II bicycle lanes on Milvia with a Class IV cycle track; and

WHEREAS, the City has strong health, safety and environmental interest in building protected bikeway infrastructure on Milvia Street; and

WHEREAS, while initial funding for a protected bikeway has been provided by a Measure B sales tax grant from the Alameda County Transportation Commission, the City can leverage additional funding to accelerate the design and construction of a near-term protected bikeway pilot between University Avenue and Allston Way; and

WHEREAS, Streets and Open Space Improvement Fee (SOSIF) funds are available to cover the costs associated with the pilot; and

WHEREAS, the Department of Public Works projects a \$432,592 gross SOSIF fund balance for FY 2020; and

NOW THEREFORE, BE IT RESOLVED by the Council of the City of Berkeley that it hereby approves allocating \$400,000 in SOSIF funds for the design and construction of a protected Milvia Bikeway pilot project between University Avenue and Allston Way.



Office of the City Manager

INFORMATION CALENDAR

April 23, 2019

To: Honorable Mayor and Members of the City Council

From: Dee Williams-Ridley, City Manager

Submitted by: Paul Buddenhagen, Deputy City Manager

Subject: Ethical Climate Audit Status Report

INTRODUCTION

On March 14, 2017, the City Auditor submitted an Ethical Climate audit report<sup>1</sup> with recommendations to strengthen the City's commitment to improving its progress in maintaining a transparent, equitable, and ethical workplace. The purpose of this information item is to update City Council on the status of implementing the audit recommendations. This is the second status report regarding this audit. The City Manager's Office issued its first response on September 13, 2018.<sup>2</sup>

CURRENT SITUATION AND ITS EFFECTS

As of the writing of this report, one recommendation has been implemented, three recommendations have been partially implemented and two have not been implemented, but are in progress. The Human Resources Department has convened an interdepartmental, citywide ethics committee, which has met twice. This committee is the lead body that will support the citywide implementation of initiatives to build a transparent, equitable, and ethical workplace.

Please see Attachment 1 for a detailed table of audit report recommendations, corrective action plans, and implementation progress. The next status report to Council is expected to be provided October 15, 2019.

BACKGROUND

To help the City provide employees with a positive and supportive workplace, and the public with effective and efficient service delivery, the Office of the City Auditor (City Auditor) did an audit of the City's ethical climate. The City Auditor determined that the best way to understand how employees view the City's ethical climate was with a confidential survey, asking how they perceive their work environment and whether they believe management supports an ethical workplace.

---

<sup>1</sup> Audit Report: Berkeley's Ethical Climate Rated Strong Overall and Management Working to Make it Better, <https://bit.ly/2yviSNY>.

<sup>2</sup> Ethical Climate Audit Status Report, <https://bit.ly/2EVUadr>.

ENVIRONMENTAL SUSTAINABILITY

There are no identifiable environmental effects associated with the subject of this report.

POSSIBLE FUTURE ACTION

The City Manager's Office will continue to work with the Human Resources Department and the Ethics Committee to implement the audit recommendations.

FISCAL IMPACTS OF POSSIBLE FUTURE ACTION

None at this time.

CONTACT PERSON

Paul Buddenhagen, Deputy City Manager, City Manager's Office, 510 981-7014

Attachments:

1: Audit Findings, Recommendations, and Management Response Summary table

**City of Berkeley City Auditor’s Office  
Audit Findings and Recommendations Response Form**

| <b>Audit Title: Berkeley’s Ethical Climate Rated Strong Overall and Management Working to Make it Better</b>                           |                                                                                                                                                                                                                                                                                                                                                                                                                                                                                                                                            |                                                |                                               |                                                                                                                                                                                                                                                                                                                                                                                                                        |                                                                                                                                                                                                                                                                                                                                                                                                                                                                                                                                                                                                                                                                                                                                                                                                                                                                                                                                                                        |
|----------------------------------------------------------------------------------------------------------------------------------------|--------------------------------------------------------------------------------------------------------------------------------------------------------------------------------------------------------------------------------------------------------------------------------------------------------------------------------------------------------------------------------------------------------------------------------------------------------------------------------------------------------------------------------------------|------------------------------------------------|-----------------------------------------------|------------------------------------------------------------------------------------------------------------------------------------------------------------------------------------------------------------------------------------------------------------------------------------------------------------------------------------------------------------------------------------------------------------------------|------------------------------------------------------------------------------------------------------------------------------------------------------------------------------------------------------------------------------------------------------------------------------------------------------------------------------------------------------------------------------------------------------------------------------------------------------------------------------------------------------------------------------------------------------------------------------------------------------------------------------------------------------------------------------------------------------------------------------------------------------------------------------------------------------------------------------------------------------------------------------------------------------------------------------------------------------------------------|
| <b>Findings and Recommendations</b>                                                                                                    | <b>Lead Dept.</b>                                                                                                                                                                                                                                                                                                                                                                                                                                                                                                                          | <b>Agree, Partially Agree, or Do Not Agree</b> | <b>Expected or Actual Implementation Date</b> | <b>Status of Audit Recommendations, Corrective Action Plan, and Progress Summary</b>                                                                                                                                                                                                                                                                                                                                   |                                                                                                                                                                                                                                                                                                                                                                                                                                                                                                                                                                                                                                                                                                                                                                                                                                                                                                                                                                        |
| <b>Finding 1</b> The City can improve service delivery, employee morale, and public trust by further strengthening its ethical climate |                                                                                                                                                                                                                                                                                                                                                                                                                                                                                                                                            |                                                |                                               |                                                                                                                                                                                                                                                                                                                                                                                                                        |                                                                                                                                                                                                                                                                                                                                                                                                                                                                                                                                                                                                                                                                                                                                                                                                                                                                                                                                                                        |
| 1.1                                                                                                                                    | Establish a formal, public-sector-values based, ethics program by:<br>1) Adopting a code of ethics that identifies important ethical principles or values and how to integrate the code into day to day practices.<br>2) Designating high-level personnel (a specific individual or individuals) to ensure the organization has an effective ethics program<br>3) Identifying City staff member(s) or external resource to whom employees can turn for ethics advice<br>4) Providing staff with guidance on how to tackle ethical dilemmas | City Manager’s Office                          | Agree                                         | <p><u>Various</u></p> <p>1) Sept. 2017: Establishment of Code of Ethics<br/>Updated: Dec. 2018</p> <p>2) Sept. 2017: Personnel designation<br/>Updated: Dec. 2018</p> <p>3) Dec. 2017: Identification of staff or external resources<br/>Updated: Dec. 2018</p> <p>4) June 2018: Staff guidance on tackling ethical dilemmas (while some components may come sooner, this recommendation will be fully implemented</p> | <p>In progress (Deputy City Manager is the lead with major support from Human Resources)</p> <p><b>Status Update 9/11/18:</b> Partially Implemented.</p> <p>1.1.1 The Deputy City Manager conducted brainstorming of principles and values and discussions with directors and managers on how ethical dilemmas have manifested during their careers.</p> <p>1.1.2 The Deputy City Manager and the Director of the Human Resources Department are leading the effort. Additionally there is an ethic program workgroup has been established that consists of staff from the following departments: Attorney, Clerk, Information Technology, Human Resources and City Manager.</p> <p>1.1.3 Staff can turn to supervisors and managers for ethics advice. This will be formally announced when the City’s ethics program is completed.</p> <p>1.1.4 This will be informed by the City’s Ethics Code once complete.</p> <p><b>Status Update 4/23/19:</b> Implemented.</p> |

| Audit Title: Berkeley's Ethical Climate Rated Strong Overall and Management Working to Make it Better |  |            |                                         |                                                                          |                                                                                                                                                                                                                                                                                                                                                                                                                                                                                                                                                                                                                                                                                                                                                                                                                                                                                                                                                                                                                                                                                                                                                                                                                                                                                                                                                                                                       |
|-------------------------------------------------------------------------------------------------------|--|------------|-----------------------------------------|--------------------------------------------------------------------------|-------------------------------------------------------------------------------------------------------------------------------------------------------------------------------------------------------------------------------------------------------------------------------------------------------------------------------------------------------------------------------------------------------------------------------------------------------------------------------------------------------------------------------------------------------------------------------------------------------------------------------------------------------------------------------------------------------------------------------------------------------------------------------------------------------------------------------------------------------------------------------------------------------------------------------------------------------------------------------------------------------------------------------------------------------------------------------------------------------------------------------------------------------------------------------------------------------------------------------------------------------------------------------------------------------------------------------------------------------------------------------------------------------|
| Findings and Recommendations                                                                          |  | Lead Dept. | Agree, Partially Agree, or Do Not Agree | Expected or Actual Implementation Date                                   | Status of Audit Recommendations, Corrective Action Plan, and Progress Summary                                                                                                                                                                                                                                                                                                                                                                                                                                                                                                                                                                                                                                                                                                                                                                                                                                                                                                                                                                                                                                                                                                                                                                                                                                                                                                                         |
|                                                                                                       |  |            |                                         | with full program implementation)<br>Actual Implementation<br>March 2019 | <p>1.1.1 The new code of ethics for the City of Berkeley was revised and distributed citywide on February 15, 2019 via a Berkeley Matters newsletter and included as a part of a new hire orientation. The revised code identifies important ethical principles (e.g., fairness, equality, respect, etc) and contains language identifying ethical actions in daily practices (e.g., not wasting City property, not borrowing property for City use, contributing to a trustworthy team, etc).</p> <p>1.1.2 A formal ethics committee led by the HR Director was created and began monthly meetings in December 2018. The aforementioned ethics committee was convened at the joint direction of the Deputy City Manager and Director of the Human Resources Department. Department Directors identified staff to serve on the committee and represent their respective departments.</p> <p>1.1.3 The February 15, 2019 Berkeley Matters newsletter announced the Ethics Committee as “a resource to route different ethics issues appropriately” and noted that “when in doubt or feel concerned” staff “can speak to any of the Committee members or call a confidential ethics hotline. The newsletter also provided names, email address, and departments for all Ethics Committee member, as well as 1-800 number for the hotline. Additionally, staff may turn to supervisors for guidance.</p> |

| Audit Title: Berkeley's Ethical Climate Rated Strong Overall and Management Working to Make it Better |                                                                                                                                                                                                                                                                                                                                                                                                                                                                                                                                                                                                                                                                                                                                                                                                                 |                       |                                         |                                                                                                                                                                                                                                                                                                                                                                                                              |                                                                                                                                                                                                                                                                                                                                                                                                                                                                                                                                                                                                                                                                                                                                                                                                                                                                                                 |
|-------------------------------------------------------------------------------------------------------|-----------------------------------------------------------------------------------------------------------------------------------------------------------------------------------------------------------------------------------------------------------------------------------------------------------------------------------------------------------------------------------------------------------------------------------------------------------------------------------------------------------------------------------------------------------------------------------------------------------------------------------------------------------------------------------------------------------------------------------------------------------------------------------------------------------------|-----------------------|-----------------------------------------|--------------------------------------------------------------------------------------------------------------------------------------------------------------------------------------------------------------------------------------------------------------------------------------------------------------------------------------------------------------------------------------------------------------|-------------------------------------------------------------------------------------------------------------------------------------------------------------------------------------------------------------------------------------------------------------------------------------------------------------------------------------------------------------------------------------------------------------------------------------------------------------------------------------------------------------------------------------------------------------------------------------------------------------------------------------------------------------------------------------------------------------------------------------------------------------------------------------------------------------------------------------------------------------------------------------------------|
| Findings and Recommendations                                                                          |                                                                                                                                                                                                                                                                                                                                                                                                                                                                                                                                                                                                                                                                                                                                                                                                                 | Lead Dept.            | Agree, Partially Agree, or Do Not Agree | Expected or Actual Implementation Date                                                                                                                                                                                                                                                                                                                                                                       | Status of Audit Recommendations, Corrective Action Plan, and Progress Summary                                                                                                                                                                                                                                                                                                                                                                                                                                                                                                                                                                                                                                                                                                                                                                                                                   |
|                                                                                                       |                                                                                                                                                                                                                                                                                                                                                                                                                                                                                                                                                                                                                                                                                                                                                                                                                 |                       |                                         |                                                                                                                                                                                                                                                                                                                                                                                                              | 1.1.4 The February 15, 2019 Berkeley Matters newsletter and the revised code of ethics provide a variety of ways to gain guidance on ethical dilemmas: attending 3Cs trainings, reading administrative regulations, contacting an Ethics Committee member, or call the ethics hotline. Additionally, staff may turn to supervisors for guidance.                                                                                                                                                                                                                                                                                                                                                                                                                                                                                                                                                |
| 1.2                                                                                                   | <p>Promote ethical standards to employees and the public by:</p> <ol style="list-style-type: none"> <li>1) Including the City's ethics statement in the new employee packet and discussing the City's commitment to ethical standards in new employee orientation</li> <li>2) Providing all employees with training covering the City's ethics-related policies and incorporating key aspects of the Fair Political Practices Commission ethics training</li> <li>3) Providing a variety of ways to access ethics information and resources for employees, including those with no regular computer access at work, such as:                             <ul style="list-style-type: none"> <li>• Posters and wallet cards</li> <li>• Centralized, intranet-based ethics resource center</li> </ul> </li> </ol> | City Manager's Office | Agree                                   | <p><u>Various</u></p> <ol style="list-style-type: none"> <li>1) Sept. 2017: Ethics inclusion in employee orientation materials<br/>Updated: March 2019</li> <li>2) June 2018: Establishment of ethics training for all employees<br/>Updated: March 2019</li> <li>3) June 2018 or sooner: Providing access to ethical information for employees without regular computer access (portions of this</li> </ol> | <p>Work on this recommendation will begin in June 2017 (or sooner) when the Code of Ethics is established. (Deputy City Manager is the lead with major support from Human Resources)</p> <p><b>Status Update 9/11/18:</b> Not Implemented. In progress.</p> <p><b>Status Update 4/23/19:</b> Partially Implemented.</p> <p>1.2.1 As of October 2018, the <i>New Hire Orientation</i> includes an ethics overview and a review of the City of Berkeley ethics statement.</p> <p>1.2.2 As of October 2018, the Training Division has worked to incorporate ethics training modules citywide.</p> <p>1.2.3 In December 2018, the ethics committee identified different communication channels, including posters, an 800 number, and messages in the citywide biweekly e-newsletter, <i>Berkeley Matters</i>. The committee plans to begin using these channels during the first half of 2019.</p> |

| <b>Audit Title: Berkeley's Ethical Climate Rated Strong Overall and Management Working to Make it Better</b>                                                                                                                                                                                                                                                                                                                                                   |                   |                                                |                                                                                                                                                                                                                                                                                                                                                                                                                                           |                                                                                      |
|----------------------------------------------------------------------------------------------------------------------------------------------------------------------------------------------------------------------------------------------------------------------------------------------------------------------------------------------------------------------------------------------------------------------------------------------------------------|-------------------|------------------------------------------------|-------------------------------------------------------------------------------------------------------------------------------------------------------------------------------------------------------------------------------------------------------------------------------------------------------------------------------------------------------------------------------------------------------------------------------------------|--------------------------------------------------------------------------------------|
| <b>Findings and Recommendations</b>                                                                                                                                                                                                                                                                                                                                                                                                                            | <b>Lead Dept.</b> | <b>Agree, Partially Agree, or Do Not Agree</b> | <b>Expected or Actual Implementation Date</b>                                                                                                                                                                                                                                                                                                                                                                                             | <b>Status of Audit Recommendations, Corrective Action Plan, and Progress Summary</b> |
| <ul style="list-style-type: none"> <li>• Periodic inclusion of ethics statement in Berkeley Matters</li> </ul> <p>4) Emphasizing the City's commitment to workplace ethics during formal meetings, informal staff discussions, and regular communications with outside parties</p> <p>5) Making the code of ethics available to the public, such as including the ethics code and related material in a centralized location on the City's public internet</p> |                   |                                                | <p>will be completed with other recommendation, but completion will simultaneous with full ethics program implementation)</p> <p>Updated: March 2019</p> <p>4) September 2017: emphasizing ethical commitment (started with 4-13-18 work plan meeting. To be formalized with full program implementation)</p> <p>Updated: April 2018, on-going</p> <p>5) Sept. 2017: Code of Ethics on the public internet</p> <p>Updated: March 2019</p> | <p>1.2.4 See 9/11/18 update.</p> <p>1.2.5 See 9/11/18 update.</p>                    |



| Audit Title: Berkeley’s Ethical Climate Rated Strong Overall and Management Working to Make it Better |                                                                                                                                                                                                                                                                                                                                                                                                                                                         |                       |                                         |                                                                                                                                                                                                                              |                                                                                                                                                                                                                                                                                                                                                                                                                                                                                                                                                                                                                                                                                                                                                                                                                                                                                                                                                                                                                                                                                                                                                                                                                                                                                                                                                                                                            |
|-------------------------------------------------------------------------------------------------------|---------------------------------------------------------------------------------------------------------------------------------------------------------------------------------------------------------------------------------------------------------------------------------------------------------------------------------------------------------------------------------------------------------------------------------------------------------|-----------------------|-----------------------------------------|------------------------------------------------------------------------------------------------------------------------------------------------------------------------------------------------------------------------------|------------------------------------------------------------------------------------------------------------------------------------------------------------------------------------------------------------------------------------------------------------------------------------------------------------------------------------------------------------------------------------------------------------------------------------------------------------------------------------------------------------------------------------------------------------------------------------------------------------------------------------------------------------------------------------------------------------------------------------------------------------------------------------------------------------------------------------------------------------------------------------------------------------------------------------------------------------------------------------------------------------------------------------------------------------------------------------------------------------------------------------------------------------------------------------------------------------------------------------------------------------------------------------------------------------------------------------------------------------------------------------------------------------|
| Findings and Recommendations                                                                          |                                                                                                                                                                                                                                                                                                                                                                                                                                                         | Lead Dept.            | Agree, Partially Agree, or Do Not Agree | Expected or Actual Implementation Date                                                                                                                                                                                       | Status of Audit Recommendations, Corrective Action Plan, and Progress Summary                                                                                                                                                                                                                                                                                                                                                                                                                                                                                                                                                                                                                                                                                                                                                                                                                                                                                                                                                                                                                                                                                                                                                                                                                                                                                                                              |
|                                                                                                       |                                                                                                                                                                                                                                                                                                                                                                                                                                                         |                       |                                         | Expected Implementation December 2019                                                                                                                                                                                        |                                                                                                                                                                                                                                                                                                                                                                                                                                                                                                                                                                                                                                                                                                                                                                                                                                                                                                                                                                                                                                                                                                                                                                                                                                                                                                                                                                                                            |
| 1.3                                                                                                   | <p>Provide supervisors and midlevel management with written guidance and training on how to:</p> <ul style="list-style-type: none"> <li>• Initiate and encourage discussions of ethical issues to help dispel misconceptions and alert management to actual problems</li> <li>• Report concerns or complaints to management or external resource, and conduct investigations of ethics related complaints according to the City’s procedures</li> </ul> | City Manager’s Office | Agree                                   | <p>June 2018: Provide supervisors and midlevel management with written guidance and training (this will be combined with full program implementation)</p> <p>Updated: Dec. 2018</p> <p>Expected Implementation Dec. 2019</p> | <p>Work on this recommendation will begin in June 2017 (or sooner) when the Code of Ethics is established. (Deputy City Manager is the lead with major support from Human Resources)</p> <p><b>Status Update 9/11/18:</b> Not Implemented. In progress. The department directors and managers have identified key components to include in the City’s ethical standards. These components will need to be further shaped and formalized into a Code of Ethics. Implementation was delayed due to staff workload. Going forward, development of the Code of Ethics and the ethics program will lead by the Deputy City Manager and Human Resources Director.</p> <p><b>Status Update 4/23/19:</b> Partially Implemented. At the first ethics committee meeting, in December 2018, each committee member received written guidance (i.e., <i>Developing a Local Agency Ethics Code</i> by the Institute for Local Self Government and <i>Understanding the Basics of Public Service Ethics</i> by the Institute for Local Government). Also, the Leadership Development Program, a training for midlevel managers and supervisors, now incorporates an ethics section in the training. Additionally, the Human Resources department provides a New Supervisors training to all new supervisors/managers and supervisors/managers who are new-to-the-city. This training includes guidance on the ethical</p> |

| Audit Title: Berkeley's Ethical Climate Rated Strong Overall and Management Working to Make it Better |                                                                                                                                                                           |                       |                                         |                                                                           |                                                                                                                                                                                                                                                                                                                                                                                                                                                                                                                                                                                                                                                                                                                                                                                                                                                                                                                                                                                                         |
|-------------------------------------------------------------------------------------------------------|---------------------------------------------------------------------------------------------------------------------------------------------------------------------------|-----------------------|-----------------------------------------|---------------------------------------------------------------------------|---------------------------------------------------------------------------------------------------------------------------------------------------------------------------------------------------------------------------------------------------------------------------------------------------------------------------------------------------------------------------------------------------------------------------------------------------------------------------------------------------------------------------------------------------------------------------------------------------------------------------------------------------------------------------------------------------------------------------------------------------------------------------------------------------------------------------------------------------------------------------------------------------------------------------------------------------------------------------------------------------------|
| Findings and Recommendations                                                                          |                                                                                                                                                                           | Lead Dept.            | Agree, Partially Agree, or Do Not Agree | Expected or Actual Implementation Date                                    | Status of Audit Recommendations, Corrective Action Plan, and Progress Summary                                                                                                                                                                                                                                                                                                                                                                                                                                                                                                                                                                                                                                                                                                                                                                                                                                                                                                                           |
|                                                                                                       |                                                                                                                                                                           |                       |                                         |                                                                           | expectations for public employees and city policies relating to ethics.                                                                                                                                                                                                                                                                                                                                                                                                                                                                                                                                                                                                                                                                                                                                                                                                                                                                                                                                 |
| 1.4                                                                                                   | Develop a system for tracking, analyzing, and reporting on suspected misconduct, including written guidance and forms (or similar) to assist employees in making reports. | City Manager's Office | Agree                                   | Dec. 2017<br>Updated: March 2019<br>Expected Implementation December 2019 | In progress (Deputy City Manager is the lead with major support from Human Resources)<br><b>Status Update 9/11/18:</b> Not Implemented. In progress. The ethics program working group will assess current practices, develop enhancements to the current system for tracking, analyzing, and reporting on suspected ethics misconduct.<br><b>Status Update 4/23/19:</b> Not Implemented. In progress. In December 2018, the ethics committee identified different communication channels, including posters, an 800 number (i.e., for reporting), and messages in the citywide biweekly e-newsletter, <i>Berkeley Matters</i> . The committee plans to begin using these channels during the first half of 2019 for increasing staff awareness of how to report suspected misconduct. Currently, the City relies on Microsoft Excel to track reports of suspected misconduct. The Human Resources department is working with the IT department to identify and procure a modern case management system. |
| 1.5                                                                                                   | Provide employees and the City Council with summary reports about investigation and resolution of employee ethics complaints, such                                        | City Manager's Office | Partially Agree                         | n/a                                                                       | While providing summary information to employees and the City Council can be beneficial, at this time (without the full ethics program established), it is not possible to determine if a summary                                                                                                                                                                                                                                                                                                                                                                                                                                                                                                                                                                                                                                                                                                                                                                                                       |

| Audit Title: Berkeley's Ethical Climate Rated Strong Overall and Management Working to Make it Better |                                                                                                                        |                       |                                         |                                                                                                                                         |                                                                                                                                                                                                                                                                                                                                                                                                                                                                                                                                                                                                                                                                                                                                       |
|-------------------------------------------------------------------------------------------------------|------------------------------------------------------------------------------------------------------------------------|-----------------------|-----------------------------------------|-----------------------------------------------------------------------------------------------------------------------------------------|---------------------------------------------------------------------------------------------------------------------------------------------------------------------------------------------------------------------------------------------------------------------------------------------------------------------------------------------------------------------------------------------------------------------------------------------------------------------------------------------------------------------------------------------------------------------------------------------------------------------------------------------------------------------------------------------------------------------------------------|
| Findings and Recommendations                                                                          |                                                                                                                        | Lead Dept.            | Agree, Partially Agree, or Do Not Agree | Expected or Actual Implementation Date                                                                                                  | Status of Audit Recommendations, Corrective Action Plan, and Progress Summary                                                                                                                                                                                                                                                                                                                                                                                                                                                                                                                                                                                                                                                         |
|                                                                                                       | as the reports already provided about EEO complaints, taking care to protect confidential and identifying information. |                       |                                         |                                                                                                                                         | <p>report can be established in a manner that is detailed enough to be informative to employees and the City Council, and also non-specific enough to protect the confidentiality of personnel issues. CMO will assess after implementation of the full ethics program.</p> <p><b>Status Update 9/11/18:</b> Not Implemented.<br/>After the City has established a formal ethics program, the City Manager's Office will assess the feasibility of a summary report.</p> <p><b>Status Update 4/23/19:</b> Not Implemented.<br/>See 9/11/18 update.</p>                                                                                                                                                                                |
| 1.6                                                                                                   | Monitor and regularly evaluate the effectiveness of the ethics program and make improvements based on results.         | City Manager's Office | Agree                                   | <p>June 2018 (this will follow full program implementation)</p> <p>Updated: March 2019</p> <p>Expected Implementation December 2019</p> | <p>Not started</p> <p><b>Status Update 9/11/18:</b> Not Implemented.<br/>After the City has established a formal ethics program, the City Manager's Office will monitor and evaluate its effectiveness and make improvements based on results.</p> <p><b>Status Update 4/23/19:</b> Partially Implemented.<br/>In an October memorandum to the Senior Executive Team, the Training Officer summarized the tasks of the ethics committee, including evaluation (i.e., metrics, analysis, and reporting), quality control, and continuous improvement. The Human Resources department is working with the IT department to identify and procure a modern case management system which will aide in analysis and evaluation efforts.</p> |





Office of the City Manager

INFORMATION CALENDAR

April 23, 2019

To: Honorable Mayor and Members of the City Council

From: Dee Williams-Ridley, City Manager

Submitted by: Dave Brannigan, Fire Chief, Fire Department

Subject: Ambulance Billing Follow-up Audit Status Report

INTRODUCTION

On March 28, 2017, the City Auditor submitted an [Ambulance Billing Follow-up](#) audit report<sup>1</sup> to the City Council with recommendations to improve the Berkeley Fire Department's ambulance billing and collection efforts and to write off receivables that were determined to be uncollectible. This information item updates City Council on the status of implementation of the audit report's recommendations. This is the second and final status report regarding this audit. The first status report was submitted on October 3, 2017.

CURRENT SITUATION AND ITS EFFECTS

The audit included ten recommendations. As of the writing of this report, all ten recommendations are implemented (7 "implemented", 3 "alternatively implemented.")

Please see Attachment 1 for a detailed table of audit report recommendations, corrective action plans, and implementation progress.

BACKGROUND

The Berkeley Fire Department responds to medical emergency calls, provides medical treatment, and transports Berkeley residents to appropriate medical facilities. The department staffed three ambulances around the clock with two trained paramedics on each ambulance to provide necessary medical care. Due to the surging demand for ambulance services, effective July 1, 2017, one ambulance was added to provide services twenty-four hours a day, seven days a week. The Berkeley Fire Department engaged a third party contractor (Intermedix) to bill for the service and to collect fees.

---

<sup>1</sup> Audit: Berkeley Fire Department Ambulance Billing Follow-Up (3/28/17):  
[https://www.cityofberkeley.info/Clerk/City\\_Council/2017/03\\_Mar/City\\_Council\\_03-28-2017\\_-\\_Regular\\_Meeting\\_Agenda.aspx](https://www.cityofberkeley.info/Clerk/City_Council/2017/03_Mar/City_Council_03-28-2017_-_Regular_Meeting_Agenda.aspx)

Ambulance Billing Follow-up Audit Status Report

Effective January 1, 2019, the billing services are provided by a new vendor, Wittman Enterprises, LLC.

ENVIRONMENTAL SUSTAINABILITY

There are no identifiable environmental impacts associated with the subject of this report.

POSSIBLE FUTURE ACTION

The Berkeley Fire Department will continue to work with the existing ambulance billing contractor, Wittman Enterprises, LLC, to improve its billing and collection efforts.

FISCAL IMPACTS OF POSSIBLE FUTURE ACTION

The collection on ambulance fees may be improved as a result of implementing the audit recommendations.

CONTACT PERSON

Dave Brannigan, Fire Chief, Fire Department, (510) 981-3473

Attachment:

1 Audit Report Form

**City of Berkeley City Auditor's Office**  
**Audit Findings and Recommendations Response Form**

Attachment 1

| Audit Title: Berkeley Fire Department Ambulance Billing Follow-Up Audit 2016                                         |                                                                                                                                                                                                                                                                                                                                                                                                                                                                                                                                                                                                                                                       |                                         |                                        |                                                                                                                                                                                                                                                                                                                                                                                                                                                                                                                                                                                                                                                                                                                                                                                                                                                                                                                                                                                                                                                                                                                                                                                                                                                                                                                                                                             |
|----------------------------------------------------------------------------------------------------------------------|-------------------------------------------------------------------------------------------------------------------------------------------------------------------------------------------------------------------------------------------------------------------------------------------------------------------------------------------------------------------------------------------------------------------------------------------------------------------------------------------------------------------------------------------------------------------------------------------------------------------------------------------------------|-----------------------------------------|----------------------------------------|-----------------------------------------------------------------------------------------------------------------------------------------------------------------------------------------------------------------------------------------------------------------------------------------------------------------------------------------------------------------------------------------------------------------------------------------------------------------------------------------------------------------------------------------------------------------------------------------------------------------------------------------------------------------------------------------------------------------------------------------------------------------------------------------------------------------------------------------------------------------------------------------------------------------------------------------------------------------------------------------------------------------------------------------------------------------------------------------------------------------------------------------------------------------------------------------------------------------------------------------------------------------------------------------------------------------------------------------------------------------------------|
| Findings and Recommendations                                                                                         | Lead Dept.                                                                                                                                                                                                                                                                                                                                                                                                                                                                                                                                                                                                                                            | Agree, Partially Agree, or Do Not Agree | Expected or Actual Implementation Date | Status of Audit Recommendations, Corrective Action Plan, and Progress Summary                                                                                                                                                                                                                                                                                                                                                                                                                                                                                                                                                                                                                                                                                                                                                                                                                                                                                                                                                                                                                                                                                                                                                                                                                                                                                               |
| <b>Finding 1: Billing efforts made more efficient but collection efforts and write-off practices remain concerns</b> |                                                                                                                                                                                                                                                                                                                                                                                                                                                                                                                                                                                                                                                       |                                         |                                        |                                                                                                                                                                                                                                                                                                                                                                                                                                                                                                                                                                                                                                                                                                                                                                                                                                                                                                                                                                                                                                                                                                                                                                                                                                                                                                                                                                             |
| 1.1                                                                                                                  | Work with Intermedix to expand collection methods: <ul style="list-style-type: none"> <li>▪ Amend the progressive language on billing notices for clarity, e.g., first notice, second notice</li> <li>▪ Increase the number of billing notices sent to patients, e.g., four or five</li> <li>▪ Add information to billing notices about installment plan options and, if approved, the sliding-fee scale program (see also recommendations 1.4 and 1.5)</li> <li>▪ Call patients to discuss payment options</li> <li>▪ Continue to make attempts to form working relationships with local hospitals to collect patient billing information</li> </ul> | Fire Department                         | Agree                                  | <p>Initial Target Date: 6-30-2017</p> <p style="text-align: center;">12-31-2017</p> <p><b><u>Initial Status 3-28-2017: Partially Implemented.</u></b></p> <ul style="list-style-type: none"> <li>• Berkeley Fire Department (BFD) will work with Intermedix to send a 4<sup>th</sup> notice with BFD's letterhead. If the City Council approves the use of a collection agency, patients will be informed on the notice that the outstanding balance will be sent to a collection agency if a payment is not made within 15 days or within a timeframe recommended by the collection agency.</li> <li>• Intermedix and BFD is in the process of executing a Data Provision Agreement with Dignity Health to gain limited access to patient information that may help to improve collections. The agreement is drafted and provided by Dignity Health. The City Attorney Office has reviewed and made changes to the agreement. The revised agreement has been forwarded to Intermedix for review and processing on 1/26/2017.</li> <li>• Currently, Intermedix offers payment options to patients by phone if the patients can be reached by phone.</li> </ul> <p><b><u>1<sup>st</sup> Status update 10-3-2017: Partially Implemented.</u></b><br/> BFD met with representatives from Kaiser Permanente of Northern California to explore the possibility for Kaiser to</p> |

**Audit Findings and Recommendations Response Form**

**Attachment 1**

| Audit Title: Berkeley Fire Department Ambulance Billing Follow-Up Audit 2016 |            |                                         |                                        |                                                                                                                                                                                                                                                                                                                                                                                                                                                                                                                                                                                                                                                                                                                                                                                                                                                                                                                                                                                                                                                                                                                                                                                                                                                                                                                                                                                                                                                                                                                                                                       |
|------------------------------------------------------------------------------|------------|-----------------------------------------|----------------------------------------|-----------------------------------------------------------------------------------------------------------------------------------------------------------------------------------------------------------------------------------------------------------------------------------------------------------------------------------------------------------------------------------------------------------------------------------------------------------------------------------------------------------------------------------------------------------------------------------------------------------------------------------------------------------------------------------------------------------------------------------------------------------------------------------------------------------------------------------------------------------------------------------------------------------------------------------------------------------------------------------------------------------------------------------------------------------------------------------------------------------------------------------------------------------------------------------------------------------------------------------------------------------------------------------------------------------------------------------------------------------------------------------------------------------------------------------------------------------------------------------------------------------------------------------------------------------------------|
| Findings and Recommendations                                                 | Lead Dept. | Agree, Partially Agree, or Do Not Agree | Expected or Actual Implementation Date | Status of Audit Recommendations, Corrective Action Plan, and Progress Summary                                                                                                                                                                                                                                                                                                                                                                                                                                                                                                                                                                                                                                                                                                                                                                                                                                                                                                                                                                                                                                                                                                                                                                                                                                                                                                                                                                                                                                                                                         |
|                                                                              |            |                                         | Actual Implementation Date: 3-1-2019   | <p>provide Intermedix with essential billing information periodically. Kaiser will bring this proposal to their Legal &amp; IT department and get back to us.</p> <p><b><u>2<sup>nd</sup> Status Update 4-23-2019: Alternative Implemented.</u></b></p> <p>The Fire Department selected a new billing service provider, Wittman Enterprises, LLC. The contract started on January 1, 2019 and the following processes have been implemented:</p> <ol style="list-style-type: none"> <li>3 invoices are sent. Patients are called 5 to 10 days after an invoice is sent if there is no responses from the patients: <ul style="list-style-type: none"> <li>1st Invoice stamped "INVOICE"</li> <li>Follow-up phone call if no response</li> <li>2<sup>nd</sup> invoice stamped "PAST DUE"</li> <li>Follow-up phone call if no response</li> <li>3<sup>rd</sup> Invoice stamped "FINAL DEMAND"</li> </ul> </li> </ol> <p>If there is no insurance information on file, an information letter with "Balance Due" is sent prior to the first invoice, followed by a phone call if there is no response.</p> <ol style="list-style-type: none"> <li>A phone number for setting up a payment plan is printed on the invoices. Patients can determine a payment arrangement that best fits their needs. After a patient agrees to a payment arrangement, a "Promise to Pay" letter is sent to the patient. The patient signs the letter and returns it to Wittman. Upon request, Wittman also assists patients to set up recurring payments on their credit cards.</li> </ol> |



## Audit Findings and Recommendations Response Form

**Attachment 1**

| Audit Title: Berkeley Fire Department Ambulance Billing Follow-Up Audit 2016 |                                                                                                                                                                                                                                                                                                                                |                                         |                                        |                                                                                                                                                                                                                                                                                                                                                                                                                                                                            |                                                                                                                                                                                                                                                                                                                                                 |
|------------------------------------------------------------------------------|--------------------------------------------------------------------------------------------------------------------------------------------------------------------------------------------------------------------------------------------------------------------------------------------------------------------------------|-----------------------------------------|----------------------------------------|----------------------------------------------------------------------------------------------------------------------------------------------------------------------------------------------------------------------------------------------------------------------------------------------------------------------------------------------------------------------------------------------------------------------------------------------------------------------------|-------------------------------------------------------------------------------------------------------------------------------------------------------------------------------------------------------------------------------------------------------------------------------------------------------------------------------------------------|
| Findings and Recommendations                                                 | Lead Dept.                                                                                                                                                                                                                                                                                                                     | Agree, Partially Agree, or Do Not Agree | Expected or Actual Implementation Date | Status of Audit Recommendations, Corrective Action Plan, and Progress Summary                                                                                                                                                                                                                                                                                                                                                                                              |                                                                                                                                                                                                                                                                                                                                                 |
|                                                                              |                                                                                                                                                                                                                                                                                                                                |                                         |                                        | 3. Wittman has relationships with Kaiser and Sutter (Nor Cal). It is currently receiving patient billing information via fax from both hospitals' systems. All parties are working to automate this process as either a "data dump" directly into Wittman's billing system or a VPN login where Wittman can retrieve data directly from the records database(s). The Fire Department will be working with Wittman to implement similar relationships with local hospitals. |                                                                                                                                                                                                                                                                                                                                                 |
| 1.2                                                                          | Submit a request to the Finance Department to write off the uncollectible account balance that is, at a minimum, over two years old. Include documentation as required by City Administrative Regulation 3.15: Write Offs of Uncollectible Receivables. Continue this practice annually. See also recommendations 1.8 and 1.9. | Fire Department                         | Agree                                  | Actual Implementation Date: 11-18-2016                                                                                                                                                                                                                                                                                                                                                                                                                                     | <b><u>Initial Status 3-28-2017: Implemented.</u></b><br>A request for write-off was submitted to Finance on 11/18/2016. The request has been approved by Finance. See Finance's response to Recommendation 1.8 below. A write-off request will be submitted to Finance annually in June as recommended.                                         |
| 1.3                                                                          | Once Finance approves and completes the ambulance fee uncollectible accounts write offs, inform Intermedix that the contractor may update its records accordingly. Instruct Intermedix to exclude from the write off Medicare and Medi-Cal accounts,                                                                           | Fire Department                         | Agree                                  | Initial Target Date: 3-21-2017                                                                                                                                                                                                                                                                                                                                                                                                                                             | <b><u>Initial Status 3-28-2017: Not Implemented</u></b><br>BFD will send Intermedix the list of written-off accounts by 3/21/2017 provided the write-off is approved by the City Council on 3/14/2017 as indicated in Finance's response to Recommendation 1.9 below.<br><br><b><u>1<sup>st</sup> Status Update 10-3-2017: Implemented.</u></b> |

## Audit Findings and Recommendations Response Form

**Attachment 1**

| Audit Title: Berkeley Fire Department Ambulance Billing Follow-Up Audit 2016 |                                                                                                                                                                                                                                                                                                                                                                                  |                 |                                         |                                                                                        |                                                                                                                                                                                                                                                                                                                                                                                                                                                                                                                                                                                                                                                      |
|------------------------------------------------------------------------------|----------------------------------------------------------------------------------------------------------------------------------------------------------------------------------------------------------------------------------------------------------------------------------------------------------------------------------------------------------------------------------|-----------------|-----------------------------------------|----------------------------------------------------------------------------------------|------------------------------------------------------------------------------------------------------------------------------------------------------------------------------------------------------------------------------------------------------------------------------------------------------------------------------------------------------------------------------------------------------------------------------------------------------------------------------------------------------------------------------------------------------------------------------------------------------------------------------------------------------|
| Findings and Recommendations                                                 |                                                                                                                                                                                                                                                                                                                                                                                  | Lead Dept.      | Agree, Partially Agree, or Do Not Agree | Expected or Actual Implementation Date                                                 | Status of Audit Recommendations, Corrective Action Plan, and Progress Summary                                                                                                                                                                                                                                                                                                                                                                                                                                                                                                                                                                        |
|                                                                              | if appropriate. Repeat this process each time write offs are completed.                                                                                                                                                                                                                                                                                                          |                 |                                         | Actual Implementation Date:<br>3-28-2017                                               | <p>The list of accounts being written off, approved by Council Resolution 67,874 on March 28, 2017, was sent to Intermedix on April 6, 2017. The written off accounts were closed. Uncollectible receivables will be written off by August each year based on the following three criteria. A list of accounts being written off will be sent to Intermedix and Finance.</p> <ul style="list-style-type: none"> <li>• 100% of Indigent/Homeless if Over 1 Year at year-end.</li> <li>• 100% of Bad Address if Over 2 Years at year-end</li> <li>• 100% of Outstanding Receivables If Over 3 Years at year-end</li> </ul>                             |
| 1.4                                                                          | In collaboration with the City Manager's Office, develop and propose to City Council a sliding-fee scale pilot program that would allow patients to pay a discounted rate based on income levels within defined low-income ranges. This would apply to only the portion of the ambulance fee for which a patient is responsible after Medicare, Medi-Cal, or insurance coverage. | Fire Department | Partially Agree                         | <p>Initial Target Date:<br/>8-31-2017</p> <p style="text-align: right;">12-31-2017</p> | <p><b><u>Initial Status 3-28-2017: Alternative Will Be Implemented.</u></b></p> <p>Due to the uncertainty over the changes to the Affordable Care Act and the intensive efforts required from staff to implement a sliding-fee scale program, the costs will outweigh the benefits.</p> <p>As alternatives: 1) BFD will offer <b>MediCare/MediCal</b> patients, who have co-pay requirements, various payment plan options through Intermedix, and 2) will explore the feasibility of engaging a collection agency to pursue collection for receivables that are outstanding for 120 days to 3 years or as recommended by the collection agency.</p> |

## Audit Findings and Recommendations Response Form

**Attachment 1**

| Audit Title: Berkeley Fire Department Ambulance Billing Follow-Up Audit 2016 |                                                                                                                                                                                                                                                                                                                     |                                         |                                         |                                                                                                                                                                                                                                                                                                                                                                                                                                                                                                                                                                                                                                                                                                                                                                                                                                                                                                                                                                             |                                                                                                                                                                                                                                                                                                                                                                                                                             |
|------------------------------------------------------------------------------|---------------------------------------------------------------------------------------------------------------------------------------------------------------------------------------------------------------------------------------------------------------------------------------------------------------------|-----------------------------------------|-----------------------------------------|-----------------------------------------------------------------------------------------------------------------------------------------------------------------------------------------------------------------------------------------------------------------------------------------------------------------------------------------------------------------------------------------------------------------------------------------------------------------------------------------------------------------------------------------------------------------------------------------------------------------------------------------------------------------------------------------------------------------------------------------------------------------------------------------------------------------------------------------------------------------------------------------------------------------------------------------------------------------------------|-----------------------------------------------------------------------------------------------------------------------------------------------------------------------------------------------------------------------------------------------------------------------------------------------------------------------------------------------------------------------------------------------------------------------------|
| Findings and Recommendations                                                 | Lead Dept.                                                                                                                                                                                                                                                                                                          | Agree, Partially Agree, or Do Not Agree | Expected or Actual Implementation Date  | Status of Audit Recommendations, Corrective Action Plan, and Progress Summary                                                                                                                                                                                                                                                                                                                                                                                                                                                                                                                                                                                                                                                                                                                                                                                                                                                                                               |                                                                                                                                                                                                                                                                                                                                                                                                                             |
|                                                                              |                                                                                                                                                                                                                                                                                                                     |                                         | Actual Implementation Date:<br>3-1-2019 | <p><b><u>1<sup>st</sup> Status Update 10-3-2017: Alternative Will Be Implemented.</u></b><br/>           BFD is currently working with Intermedix to develop a protocol to offer MediCare/MediCal patients, who have co-pay requirements, various payment plan options through Intermedix.<br/>           BFD will continue to explore the feasibility of engaging a collection agency to pursue collection for receivables that are outstanding for 120 days to 3 years or as recommended by the collection agency.</p> <p><b><u>2<sup>nd</sup> Status Update 4-23-2019: Alternative Implemented.</u></b><br/>           As an alternative to a sliding-fee scale program or engaging a collection agency, the new contractor Wittman will assess patients' ability to pay and offer payment extension, reduced payments, or payment plan option to patients who cannot not make a full payment on-time due to financial hardship (Also see responses to Finding 1.1).</p> |                                                                                                                                                                                                                                                                                                                                                                                                                             |
| 1.5                                                                          | If City Council approves the sliding-fee scale pilot program: <ul style="list-style-type: none"> <li>▪ Begin offering it to patients and monitor its success rate. If successful, i.e., if revenues increase with minimal additional costs, obtain City Council approval to continue the program. If not</li> </ul> | Fire Department                         | Partially agree                         | Initial Target Date:<br>8-31-2017                                                                                                                                                                                                                                                                                                                                                                                                                                                                                                                                                                                                                                                                                                                                                                                                                                                                                                                                           | <p><b><u>Initial Status 3-28-2017: Alternative Will Be Implemented.</u></b><br/>           Due to the uncertainty over the changes to the Affordable Care Act and the intensive efforts required from staff to implement a sliding-fee scale program, the costs will outweigh the benefits.<br/>           As an alternative, BFD will explore the feasibility of engaging a collection agency to pursue collection for</p> |

## Audit Findings and Recommendations Response Form

**Attachment 1**

| Audit Title: Berkeley Fire Department Ambulance Billing Follow-Up Audit 2016                                                                                                                                                                                                                                                                                                                                                  |                 |                                         |                                                                                                                           |                                                                                                                                                                                                                                                                                                                                                                                                                                                                                                                                                                                                                                                                                                                                                                                                                                                                                                                                                                                |
|-------------------------------------------------------------------------------------------------------------------------------------------------------------------------------------------------------------------------------------------------------------------------------------------------------------------------------------------------------------------------------------------------------------------------------|-----------------|-----------------------------------------|---------------------------------------------------------------------------------------------------------------------------|--------------------------------------------------------------------------------------------------------------------------------------------------------------------------------------------------------------------------------------------------------------------------------------------------------------------------------------------------------------------------------------------------------------------------------------------------------------------------------------------------------------------------------------------------------------------------------------------------------------------------------------------------------------------------------------------------------------------------------------------------------------------------------------------------------------------------------------------------------------------------------------------------------------------------------------------------------------------------------|
| Findings and Recommendations                                                                                                                                                                                                                                                                                                                                                                                                  | Lead Dept.      | Agree, Partially Agree, or Do Not Agree | Expected or Actual Implementation Date                                                                                    | Status of Audit Recommendations, Corrective Action Plan, and Progress Summary                                                                                                                                                                                                                                                                                                                                                                                                                                                                                                                                                                                                                                                                                                                                                                                                                                                                                                  |
| <p>successful, cease the program and provide City Council with the cost-benefit analysis explaining why the program is not achieving the desired results.</p> <ul style="list-style-type: none"> <li>▪ Promote the sliding-fee scale pilot program using various methods, e.g., introduce program on the Fire Department’s website; provide handouts to the Department of Health, Housing, and Community Services.</li> </ul> |                 |                                         | <p style="text-align: center;">12-31-2017</p> <p style="text-align: center;">Actual Implementation Date:<br/>1-1-2019</p> | <p>receivables that are outstanding for 120 days to 3 years or as recommended by the collection agency.</p> <p><b><u>1<sup>st</sup> Status Update 10-3-2017: Alternative Will Be Implemented.</u></b></p> <p>BFD will continue to explore the feasibility of engaging a collection agency to pursue collection for receivables that are outstanding for 120 days to 3 years or as recommended by the collection agency.</p> <p><b><u>2<sup>nd</sup> Status Update 4-23-2019: Alternative Implemented</u></b></p> <p>As an alternative to a sliding-fee scale program or engaging a collection agency, the new contract requires Wittman to assess patients’ ability to pay and to offer payment extension or reduced payments based on the patient’s ability and/or payment plan options to the patients as necessary. In addition, Wittman will Provide annual report showing patient opting for payment plans &amp; amount collected from payment plans during the year.</p> |
| <p>1.6 Update and reissue General Order 19.6. Include the following in the update:</p> <ul style="list-style-type: none"> <li>▪ Procedures for completing ePCR reconciliations, and obtaining and</li> </ul>                                                                                                                                                                                                                  | Fire Department | Agree                                   | <p style="text-align: center;">Initial Target Date:<br/>6-1-2017</p>                                                      | <p><b><u>Initial Status 3-28-2017: Partially implemented.</u></b></p> <p>The General Order has been updated and is now going through the internal review processes. General order is renamed to “Ambulance Billing Procedures”</p>                                                                                                                                                                                                                                                                                                                                                                                                                                                                                                                                                                                                                                                                                                                                             |

## Audit Findings and Recommendations Response Form

**Attachment 1**

| Audit Title: Berkeley Fire Department Ambulance Billing Follow-Up Audit 2016 |                                                                                                                                                                                                                                                                                                                                                                                     |                 |                                         |                                        |                                                                                                                                                                                                                                                                                                                                                                                                                                                                                                                 |  |
|------------------------------------------------------------------------------|-------------------------------------------------------------------------------------------------------------------------------------------------------------------------------------------------------------------------------------------------------------------------------------------------------------------------------------------------------------------------------------|-----------------|-----------------------------------------|----------------------------------------|-----------------------------------------------------------------------------------------------------------------------------------------------------------------------------------------------------------------------------------------------------------------------------------------------------------------------------------------------------------------------------------------------------------------------------------------------------------------------------------------------------------------|--|
| Findings and Recommendations                                                 |                                                                                                                                                                                                                                                                                                                                                                                     | Lead Dept.      | Agree, Partially Agree, or Do Not Agree | Expected or Actual Implementation Date | Status of Audit Recommendations, Corrective Action Plan, and Progress Summary                                                                                                                                                                                                                                                                                                                                                                                                                                   |  |
|                                                                              | <p>documenting supervisor's approval</p> <ul style="list-style-type: none"> <li>▪ Practices for periodic reminders to EMS personnel on the ePCR requirements</li> <li>▪ Practices for monitoring Intermedix bills and collections</li> <li>▪ Procedures for following up on open ePCRs</li> <li>▪ Collection methodologies implemented in response to recommendation 1.1</li> </ul> |                 |                                         | Actual Date:<br>7-1-2017               | <p><b><u>1<sup>st</sup> Status Update 10-3-2017: Implemented.</u></b><br/>The General Order has been updated and released.</p>                                                                                                                                                                                                                                                                                                                                                                                  |  |
| 1.7                                                                          | <p>In collaboration with Intermedix, and with input as needed by Finance, perform an accounts receivable aging analysis to determine a cut-off point for which ambulance fee accounts are deemed uncollectible. Use the result of the analysis to establish a standard process for writing off the accounts when that period has elapsed.</p>                                       | Fire Department | Agree                                   | Initial Target Date:<br>4-1-2017       | <p><b><u>Initial Status 3-28-2017: Partially Implemented.</u></b><br/>On a quarterly basis, Intermedix will send to BFD the accounts that are to be written off. Outstanding balances over 3 years will be written off. A write-off less than 3 years has to be accompanied with a justification from Intermedix. The information will be reviewed by the Administrative and Fiscal Services Manager. A request to write off account balances will be submitted to Finance annually in June as recommended.</p> |  |

## Audit Findings and Recommendations Response Form

**Attachment 1**

| Audit Title: Berkeley Fire Department Ambulance Billing Follow-Up Audit 2016 |                                                                                                                                                                                                                                                                                 |                                         |                                         |                                                                                                                                                                                                                                                                                                                                                                                                                     |                                                                                                                                                                                                                                                            |
|------------------------------------------------------------------------------|---------------------------------------------------------------------------------------------------------------------------------------------------------------------------------------------------------------------------------------------------------------------------------|-----------------------------------------|-----------------------------------------|---------------------------------------------------------------------------------------------------------------------------------------------------------------------------------------------------------------------------------------------------------------------------------------------------------------------------------------------------------------------------------------------------------------------|------------------------------------------------------------------------------------------------------------------------------------------------------------------------------------------------------------------------------------------------------------|
| Findings and Recommendations                                                 | Lead Dept.                                                                                                                                                                                                                                                                      | Agree, Partially Agree, or Do Not Agree | Expected or Actual Implementation Date  | Status of Audit Recommendations, Corrective Action Plan, and Progress Summary                                                                                                                                                                                                                                                                                                                                       |                                                                                                                                                                                                                                                            |
|                                                                              |                                                                                                                                                                                                                                                                                 |                                         | Actual Implementation Date:<br>8-1-2017 | <b><u>1<sup>st</sup> Status Update 10-3-2017: Implemented.</u></b><br>Intermedix provides an aging report to BFD on a quarterly basis. At year end, BFD & Intermedix work together to identify uncollectible accounts to be written off based on pre-established criteria. Around the end of August each year, BFD sends a detailed write-off report, with account numbers, to Finance for recording the write-off. |                                                                                                                                                                                                                                                            |
| 1.8                                                                          | Work with the Berkeley Fire Department to identify, specifically, what information is required, in accordance with City Administrative Regulation 3.15: Write Offs of Uncollectible Receivables, to write off the uncollectible accounts. See also recommendations 1.2 and 1.9. | Finance Department                      | Agree                                   | Actual Implementation Date:<br>12/20/2017                                                                                                                                                                                                                                                                                                                                                                           | <b><u>Initial Status 3-28-2017: Implemented.</u></b><br>Finance already worked with Fire and obtained the necessary supporting documentation for the write off. The write off is going to City Council on March 14, 2017.                                  |
| 1.9                                                                          | Write off the ambulance fee uncollectible balance older than the cut-off period established as result of the accounts receivable aging analysis. See also recommendation 1.2, 1.7, and 1.8. Exclude from the write off Medicare and Medi-Cal accounts, if appropriate.          | Finance Department                      | Agree                                   | Actual Implementation Date:<br>3/15/2017                                                                                                                                                                                                                                                                                                                                                                            | <b><u>Initial Status 3-28-2017: Implemented.</u></b><br>Finance approved the write off request from Fire. Finance will be going to obtain Council approval (on the 3/14/17 Council Meeting) for this write off since the total amount is material \$18.6M. |

## Audit Findings and Recommendations Response Form

**Attachment 1**

| Audit Title: Berkeley Fire Department Ambulance Billing Follow-Up Audit 2016 |                                                                                                |                                         |                                        |                                                                               |                                                      |
|------------------------------------------------------------------------------|------------------------------------------------------------------------------------------------|-----------------------------------------|----------------------------------------|-------------------------------------------------------------------------------|------------------------------------------------------|
| Findings and Recommendations                                                 | Lead Dept.                                                                                     | Agree, Partially Agree, or Do Not Agree | Expected or Actual Implementation Date | Status of Audit Recommendations, Corrective Action Plan, and Progress Summary |                                                      |
| 1.10                                                                         | Require staff use the signature section on the waiver form to demonstrate review and approval. | Finance Department                      | Agree                                  | Actual Implementation Date:<br>1/30/2017                                      | <b><u>Initial Status 3-28-2017: Implemented.</u></b> |







Office of the City Manager

INFORMATION CALENDAR  
April 23, 2019

To: Honorable Mayor and Members of the City Council

From: Dee Williams-Ridley, City Manager

Submitted by: Savita Chaudhary, Director, Department of Information Technology

Subject: Status Report: City at Crossroads as Long-Standing Need for Structured Approach to Line of Business Experts Function Intersects with ERP Implementation

#### INTRODUCTION

On January 24, 2017, the City Auditor's Office issued its report City at Crossroads as Long-Standing Need for Structured Approach to Line of Business Experts Function Intersects with ERP Implementation

([http://www.cityofberkeley.info/uploadedFiles/Auditor/Level\\_3\\_-\\_General/A.4\\_CNCL\\_Line%20of%20Business%20Experts\\_Consent%20Item.pdf](http://www.cityofberkeley.info/uploadedFiles/Auditor/Level_3_-_General/A.4_CNCL_Line%20of%20Business%20Experts_Consent%20Item.pdf)).

The audit resulted in recommendations aimed at providing a structured approach to the line of business experts' function by implementing policy and procedural guidance that defines the purpose of the function, delineates responsibilities, establishes minimum qualifications, and provides for training and development of line of business experts. The City Auditor requested the City Manager continue to report to Council on the status of those recommendations until all were fully implemented or otherwise addressed. The first status report was provided on July 25, 2017 and the department of Information Technology agreed to implement the recommendations as the FUNDS\$ replacement project is deployed. This is the second status report on Department of Information Technology progress to implement the audit recommendations since the audit report was presented to Council. Another report will be provided to Council in February 25, 2020.

#### CURRENT SITUATION AND ITS EFFECTS

The Audit Report included five recommendations, two of the five recommendations have been implemented and the remaining three will be implemented with the Enterprise Resource Planning (ERP) project which is the FUNDS\$ replacement system. Complete detail on the original recommendation and progress taken to address those recommendations is provided in the attachment to this report.

## BACKGROUND

The Department of Information Technology (IT) oversees project implementation of the City's technology systems. Project implementation often includes collaboration between a portfolio coordinator in IT and a line of business expert in the client department. The City's line of business experts' role has been in existence for approximately two decades. Coined initially as module leaders, then as application experts, the City now uses the term line of business experts. Despite changing terminology, the City has not clearly defined the business line of experts' function, roles, and responsibilities. Because of this, the resource needs to train and develop these experts are not clearly understood.

In contrast to line of business experts, the portfolio coordinator's role is more clearly defined. The portfolio coordinator acts as a project manager for the different systems and applications and is responsible for helping client departments maximize their return on technology investments. This can include helping departments prioritize, design, improve, and implement workflow systems, as well as serving as the points of contact in IT for line of business experts. Portfolio coordinators work closely with line of business experts on system implementations and upgrades.

The Portfolio Coordinator plays a critical role in the City's management of its IT application infrastructure. While the Information Technology Department's Help Desk provides front-line support for the City's software systems and computer equipment, portfolio coordinators function more as project managers for the City's integrated and standalone systems. The portfolio coordinator is responsible for helping departments maximize their return on technology investments. Portfolio coordinators accomplish this task by:

- Assisting in prioritization, design, improvement, and implementation of workflow systems,
- Conducting business analysis,
- Programming, and
- Project management.

Information Technology's portfolio coordinators serve as points of contact for line of business experts, and work closely with these individuals on system implementations and upgrades.

## ENVIRONMENTAL SUSTAINABILITY

There are no identifiable environmental effects or opportunities associated with the subject of this report.

## POSSIBLE FUTURE ACTION

The Department of Information Technology continues to review its functions and develop service level agreements with departments with defined roles and responsibilities, provisions for monitoring and amending the agreement and to identify the areas of improvement.

FISCAL IMPACTS OF POSSIBLE FUTURE ACTION

None at this time.

CONTACT PERSON

Savita Chaudhary, Director, Information Technology, 981-6541

Attachments:

1: Information Technology Audit Recommendations Summary Table

**Attachment 1:** Audit Status Report: City at Crossroads as Long-Standing Need for Structured Approach to Line of Business Experts Function Intersects with ERP Implementation

| <b>Audit Title: City at crossroads as long-standing need for structured approach to line of business experts function intersects with ERP implementation</b> |                                                                                                                                            |                   |                                                |                                                            |                                                                                                                                                                                                                                                                                                                                                                                                                                                                                                                                                                                                                 |  |
|--------------------------------------------------------------------------------------------------------------------------------------------------------------|--------------------------------------------------------------------------------------------------------------------------------------------|-------------------|------------------------------------------------|------------------------------------------------------------|-----------------------------------------------------------------------------------------------------------------------------------------------------------------------------------------------------------------------------------------------------------------------------------------------------------------------------------------------------------------------------------------------------------------------------------------------------------------------------------------------------------------------------------------------------------------------------------------------------------------|--|
| <b>Finding and Recommendations</b>                                                                                                                           |                                                                                                                                            | <b>Lead Dept.</b> | <b>Agree, Partially Agree, or Do Not Agree</b> | <b>Expected or Actual Implementation Date</b>              | <b>Status of Audit Recommendations, Corrective Action Plan, and Progress Summary</b>                                                                                                                                                                                                                                                                                                                                                                                                                                                                                                                            |  |
| <b>Finding 1: Underdeveloped line of business experts function poses risks for City’s ERP implementation</b>                                                 |                                                                                                                                            |                   |                                                |                                                            |                                                                                                                                                                                                                                                                                                                                                                                                                                                                                                                                                                                                                 |  |
| 1.1                                                                                                                                                          | Clearly define the purpose, responsibilities, minimum qualifications, and training requirements for the line of business experts function. | City Manager      | Agree                                          | June 2020<br><br><b>Status Update 4/23/19: In Progress</b> | <p><b>Status at time of audit issuance 01/24/17: In Progress –</b><br/>City Manager’s Office will work with Director of Information Technology and the Enterprise Resource Planning (ERP) Project Manager to clearly define the purpose, responsibilities, minimum qualifications, and training requirements for the line of business experts function.</p> <p>Director of IT and ERP Business Project Manager will work with Client departments to identify roles and responsibilities for business experts function as we implement the Tyler Munis ERP System for Core Financials and HR Payroll modules</p> |  |

**Attachment 1: Audit Status Report: City at Crossroads as Long-Standing Need for Structured Approach to Line of Business Experts Function Intersects with ERP Implementation**

| <b>Audit Title: City at crossroads as long-standing need for structured approach to line of business experts function intersects with ERP implementation</b> |                   |                                                |                                               |                                                                                                                                                                                                                                                                                                                                                                                                                                                                                                                                                                                                                                                                                                                                                     |
|--------------------------------------------------------------------------------------------------------------------------------------------------------------|-------------------|------------------------------------------------|-----------------------------------------------|-----------------------------------------------------------------------------------------------------------------------------------------------------------------------------------------------------------------------------------------------------------------------------------------------------------------------------------------------------------------------------------------------------------------------------------------------------------------------------------------------------------------------------------------------------------------------------------------------------------------------------------------------------------------------------------------------------------------------------------------------------|
| <b>Finding and Recommendations</b>                                                                                                                           | <b>Lead Dept.</b> | <b>Agree, Partially Agree, or Do Not Agree</b> | <b>Expected or Actual Implementation Date</b> | <b>Status of Audit Recommendations, Corrective Action Plan, and Progress Summary</b>                                                                                                                                                                                                                                                                                                                                                                                                                                                                                                                                                                                                                                                                |
|                                                                                                                                                              |                   |                                                |                                               | <p>and as various other phases of the project are implemented.</p> <p><b>Status Update 7/25/17: In progress</b><br/>To be implemented with ERP Project implementation<br/>The City selected the Tyler MUNIS in FEB 2017 and the Project Kickoff is scheduled for Jul 25, 2017 thru Jul 27, 2017</p> <p><b>Status Update 4/23/19: In Progress</b><br/>The first phase of erma included Chart of Accounts, Accounts Payable, Purchasing, Contracts and Projects went live on November 1, 2018. As training was conducted, detailed needs for future training were identified. The erma Steering Committee plans to further define the impacts to business processes as a result of changing technology and training needs. This data will help to</p> |

**Attachment 1: Audit Status Report: City at Crossroads as Long-Standing Need for Structured Approach to Line of Business Experts Function Intersects with ERP Implementation**

| <b>Audit Title: City at crossroads as long-standing need for structured approach to line of business experts function intersects with ERP implementation</b> |                   |                                                |                                               |                                                                                                                                                                                                                                                                                                                                                                                                                                                                                                                                                                                                                                                                                                                    |
|--------------------------------------------------------------------------------------------------------------------------------------------------------------|-------------------|------------------------------------------------|-----------------------------------------------|--------------------------------------------------------------------------------------------------------------------------------------------------------------------------------------------------------------------------------------------------------------------------------------------------------------------------------------------------------------------------------------------------------------------------------------------------------------------------------------------------------------------------------------------------------------------------------------------------------------------------------------------------------------------------------------------------------------------|
| <b>Finding and Recommendations</b>                                                                                                                           | <b>Lead Dept.</b> | <b>Agree, Partially Agree, or Do Not Agree</b> | <b>Expected or Actual Implementation Date</b> | <b>Status of Audit Recommendations, Corrective Action Plan, and Progress Summary</b>                                                                                                                                                                                                                                                                                                                                                                                                                                                                                                                                                                                                                               |
|                                                                                                                                                              |                   |                                                |                                               | <p>identify the roles and responsibilities for the line of business experts who will conduct future trainings to address identified training needs and convey business process changes.</p> <p>The department of IT is working to define templates for roles and responsibilities for the projects as the new systems are implemented.</p> <p>For the overall application inventory a business impact assessment (BIA) is in progress as part of Cyber Resilience efforts which will take about 18-24 months to complete the initial inventory.</p> <p>The BIA will identify the priority for support, roles and responsibilities and disaster recovery priorities for each application supported. IT staff is</p> |

**Attachment 1: Audit Status Report: City at Crossroads as Long-Standing Need for Structured Approach to Line of Business Experts Function Intersects with ERP Implementation**

| <b>Audit Title: City at crossroads as long-standing need for structured approach to line of business experts function intersects with ERP implementation</b> |                                                                                                                                                                                                                                    |                   |                                                |                                                            |                                                                                                                                                                                                                                                                                                                                                                                                                                                                                                                                                                                                |  |
|--------------------------------------------------------------------------------------------------------------------------------------------------------------|------------------------------------------------------------------------------------------------------------------------------------------------------------------------------------------------------------------------------------|-------------------|------------------------------------------------|------------------------------------------------------------|------------------------------------------------------------------------------------------------------------------------------------------------------------------------------------------------------------------------------------------------------------------------------------------------------------------------------------------------------------------------------------------------------------------------------------------------------------------------------------------------------------------------------------------------------------------------------------------------|--|
| <b>Finding and Recommendations</b>                                                                                                                           |                                                                                                                                                                                                                                    | <b>Lead Dept.</b> | <b>Agree, Partially Agree, or Do Not Agree</b> | <b>Expected or Actual Implementation Date</b>              | <b>Status of Audit Recommendations, Corrective Action Plan, and Progress Summary</b>                                                                                                                                                                                                                                                                                                                                                                                                                                                                                                           |  |
|                                                                                                                                                              |                                                                                                                                                                                                                                    |                   |                                                |                                                            | working with business departments to collect the application inventory.                                                                                                                                                                                                                                                                                                                                                                                                                                                                                                                        |  |
| 1.2                                                                                                                                                          | Work with Information Technology to establish written policies and procedures for the line of business experts function at the appropriate organizational level based on the guiding principles established in Recommendation 1.1. | City Manager      | Agree                                          | June 2020<br><br><b>Status Update 4/23/19: In Progress</b> | <p><b>Status at time of audit issuance 01/24/17: In Progress – To be implemented with ERP Project implementation</b></p> <p>City Manager’s Office will work with Director of Information Technology and the Enterprise Resource Planning (ERP) Project Manager to establish written policies and procedures for the line of business experts at the appropriate organizational level based on the guiding principles established in Recommendation 1.1.</p> <p>Director of IT and ERP Project Manager will work with the City Attorney’s Office, Finance, and Human Resources to establish</p> |  |

**Attachment 1:** Audit Status Report: City at Crossroads as Long-Standing Need for Structured Approach to Line of Business Experts Function Intersects with ERP Implementation

| <b>Audit Title: City at crossroads as long-standing need for structured approach to line of business experts function intersects with ERP implementation</b> |                   |                                                |                                               |                                                                                                                                                                                                                                                                                                                                                                                                                                                                                                                                                                                                                                                  |
|--------------------------------------------------------------------------------------------------------------------------------------------------------------|-------------------|------------------------------------------------|-----------------------------------------------|--------------------------------------------------------------------------------------------------------------------------------------------------------------------------------------------------------------------------------------------------------------------------------------------------------------------------------------------------------------------------------------------------------------------------------------------------------------------------------------------------------------------------------------------------------------------------------------------------------------------------------------------------|
| <b>Finding and Recommendations</b>                                                                                                                           | <b>Lead Dept.</b> | <b>Agree, Partially Agree, or Do Not Agree</b> | <b>Expected or Actual Implementation Date</b> | <b>Status of Audit Recommendations, Corrective Action Plan, and Progress Summary</b>                                                                                                                                                                                                                                                                                                                                                                                                                                                                                                                                                             |
|                                                                                                                                                              |                   |                                                |                                               | <p>written policies and procedures for the line of business experts as various phases of the ERP project are implemented. These policies and procedures will need to be approved by City Manager’s Office and Council as needed.</p> <p><b>Status Updated 7/25/17:</b><br/>In Progress – To be implemented with ERP Project implementation</p> <p><b>Status Update 4/23/19: In Progress</b><br/>The first phase of erma including Chart of Accounts, Accounts Payable, Purchasing, Contracts and Projects went live on November 1, 2018.</p> <p>Policies and Procedures: The internal process changes are documented in the training manuals</p> |



**Attachment 1:** Audit Status Report: City at Crossroads as Long-Standing Need for Structured Approach to Line of Business Experts Function Intersects with ERP Implementation

| <b>Audit Title: City at crossroads as long-standing need for structured approach to line of business experts function intersects with ERP implementation</b> |                                                                                                                                                                          |                        |                                                |                                                                                               |                                                                                                                                                                                                                                                                                                                                                                                                                                           |  |
|--------------------------------------------------------------------------------------------------------------------------------------------------------------|--------------------------------------------------------------------------------------------------------------------------------------------------------------------------|------------------------|------------------------------------------------|-----------------------------------------------------------------------------------------------|-------------------------------------------------------------------------------------------------------------------------------------------------------------------------------------------------------------------------------------------------------------------------------------------------------------------------------------------------------------------------------------------------------------------------------------------|--|
| <b>Finding and Recommendations</b>                                                                                                                           |                                                                                                                                                                          | <b>Lead Dept.</b>      | <b>Agree, Partially Agree, or Do Not Agree</b> | <b>Expected or Actual Implementation Date</b>                                                 | <b>Status of Audit Recommendations, Corrective Action Plan, and Progress Summary</b>                                                                                                                                                                                                                                                                                                                                                      |  |
|                                                                                                                                                              |                                                                                                                                                                          |                        |                                                |                                                                                               | <p>Training: As training was conducted the need for future training was identified and erma Steering Committee plans to identify the impacts to business processes as a result of changing technology and training needs. This data will help to identify the roles and responsibilities for the line of business experts who will conduct future trainings to address identified training needs and convey business process changes.</p> |  |
| 1.3                                                                                                                                                          | <p>Create boilerplate service level agreements that, at a minimum, define the:</p> <ul style="list-style-type: none"> <li>▪ general purpose of the agreement;</li> </ul> | Information Technology | Agree                                          | <p><b>Status Update</b><br/> <b>4/23/19:</b><br/> <b>Completed</b><br/> <b>07/01/2018</b></p> | <p><b>Status at time of audit issuance</b><br/> <b>01/24/17: In Progress – To be implemented with ERP Project implementation</b><br/>                     Information Technology department is working on replacing its Help Desk system and the new IT Service</p>                                                                                                                                                                       |  |

**Attachment 1: Audit Status Report: City at Crossroads as Long-Standing Need for Structured Approach to Line of Business Experts Function Intersects with ERP Implementation**

| <b>Audit Title: City at crossroads as long-standing need for structured approach to line of business experts function intersects with ERP implementation</b>                                                                                                                                                                                                                                                                                  |                   |                                                |                                               |                                                                                                                                                                                                                                                                                                                                                                                                                                                                                                                                                                                                                                                                                           |
|-----------------------------------------------------------------------------------------------------------------------------------------------------------------------------------------------------------------------------------------------------------------------------------------------------------------------------------------------------------------------------------------------------------------------------------------------|-------------------|------------------------------------------------|-----------------------------------------------|-------------------------------------------------------------------------------------------------------------------------------------------------------------------------------------------------------------------------------------------------------------------------------------------------------------------------------------------------------------------------------------------------------------------------------------------------------------------------------------------------------------------------------------------------------------------------------------------------------------------------------------------------------------------------------------------|
| <b>Finding and Recommendations</b>                                                                                                                                                                                                                                                                                                                                                                                                            | <b>Lead Dept.</b> | <b>Agree, Partially Agree, or Do Not Agree</b> | <b>Expected or Actual Implementation Date</b> | <b>Status of Audit Recommendations, Corrective Action Plan, and Progress Summary</b>                                                                                                                                                                                                                                                                                                                                                                                                                                                                                                                                                                                                      |
| <ul style="list-style-type: none"> <li>▪ roles and responsibilities of the parties involved;</li> <li>▪ goals and objectives;</li> <li>▪ provisions for monitoring the agreement; and</li> <li>▪ procedures for amending the agreement.</li> </ul> <p>The standard boilerplate should also include a cost section that allows for quantifying service charges and payment provisions in as much detail as possible to help justify costs.</p> |                   |                                                |                                               | <p>Management system will include the capabilities to setup and monitor the Service Level Agreements (SLA's) for the various applications supported by IT.</p> <p>IT will work with client departments to define these SLA's for the applications based on the priority and acceptable criteria as agreed by client departments. The criteria mentioned in the recommendations will be considered to create the boiler plate agreements.</p> <p><b>Status Update 7/25/17:</b><br/>In progress – To be implemented with ERP Project implementation</p> <p><b>Status Update 4/23/19: Completed 07/01/2018</b><br/>IT deployed a Cost Allocation plan including Service Level Agreements</p> |

**Attachment 1: Audit Status Report: City at Crossroads as Long-Standing Need for Structured Approach to Line of Business Experts Function Intersects with ERP Implementation**

| <b>Audit Title: City at crossroads as long-standing need for structured approach to line of business experts function intersects with ERP implementation</b> |                   |                                                |                                               |                                                                                                                                                                                                                                                                                                                                                                                                                                                                                                                                                                                                                                                                         |
|--------------------------------------------------------------------------------------------------------------------------------------------------------------|-------------------|------------------------------------------------|-----------------------------------------------|-------------------------------------------------------------------------------------------------------------------------------------------------------------------------------------------------------------------------------------------------------------------------------------------------------------------------------------------------------------------------------------------------------------------------------------------------------------------------------------------------------------------------------------------------------------------------------------------------------------------------------------------------------------------------|
| <b>Finding and Recommendations</b>                                                                                                                           | <b>Lead Dept.</b> | <b>Agree, Partially Agree, or Do Not Agree</b> | <b>Expected or Actual Implementation Date</b> | <b>Status of Audit Recommendations, Corrective Action Plan, and Progress Summary</b>                                                                                                                                                                                                                                                                                                                                                                                                                                                                                                                                                                                    |
|                                                                                                                                                              |                   |                                                |                                               | <p>for all departments in FY 19 and has started collecting data. IT presented the plan and Service Level Agreements at a Senior Executive Team meeting and answered questions, in addition to providing all directors with electronic copies of the documents. The Service Level Agreements included the description of services provided by each division, service hours, resources in each division and contact information during and after hours. The SLA's also included the description of services along with Service Level agreements based on impact and urgency.</p> <p>Starting FY20 IT department will provide annual SLA reporting to the departments.</p> |

**Attachment 1:** Audit Status Report: City at Crossroads as Long-Standing Need for Structured Approach to Line of Business Experts Function Intersects with ERP Implementation

| <b>Audit Title: City at crossroads as long-standing need for structured approach to line of business experts function intersects with ERP implementation</b> |                                                                         |                        |                                                |                                                           |                                                                                                                                                                                                                                                                                                                                                                                                                                                                                                                                                                                                                                                                                                                              |
|--------------------------------------------------------------------------------------------------------------------------------------------------------------|-------------------------------------------------------------------------|------------------------|------------------------------------------------|-----------------------------------------------------------|------------------------------------------------------------------------------------------------------------------------------------------------------------------------------------------------------------------------------------------------------------------------------------------------------------------------------------------------------------------------------------------------------------------------------------------------------------------------------------------------------------------------------------------------------------------------------------------------------------------------------------------------------------------------------------------------------------------------------|
| <b>Finding and Recommendations</b>                                                                                                                           |                                                                         | <b>Lead Dept.</b>      | <b>Agree, Partially Agree, or Do Not Agree</b> | <b>Expected or Actual Implementation Date</b>             | <b>Status of Audit Recommendations, Corrective Action Plan, and Progress Summary</b>                                                                                                                                                                                                                                                                                                                                                                                                                                                                                                                                                                                                                                         |
| 1.4                                                                                                                                                          | Negotiate and execute service level agreements with client departments. | Information Technology | Agree                                          | <p><b>Status Update 4/23/19: Completed 07/01/2018</b></p> | <p><b>Status at time of audit issuance 01/24/17: In Progress</b><br/>                     Information Technology department is working on replacing its Help Desk system and the new IT Service Management system will include the capabilities to setup and monitor progress of the Service Level Agreements (SLA's) for the various applications supported by IT. IT will work with client departments to define these SLA's for the applications based on the priority and acceptable criteria as agreed by client departments.</p> <p><b>Status Update 7/25/17: In progress</b><br/>                     To be implemented with ERP Project implementation</p> <p><b>Status Update 4/23/19: Completed 07/01/2018</b></p> |

**Attachment 1:** Audit Status Report: City at Crossroads as Long-Standing Need for Structured Approach to Line of Business Experts Function Intersects with ERP Implementation

| <b>Audit Title: City at crossroads as long-standing need for structured approach to line of business experts function intersects with ERP implementation</b> |                   |                                                |                                               |                                                                                                                                                                                                                                                                                                                                                                                                                                                                                                                                                                                                                                                |
|--------------------------------------------------------------------------------------------------------------------------------------------------------------|-------------------|------------------------------------------------|-----------------------------------------------|------------------------------------------------------------------------------------------------------------------------------------------------------------------------------------------------------------------------------------------------------------------------------------------------------------------------------------------------------------------------------------------------------------------------------------------------------------------------------------------------------------------------------------------------------------------------------------------------------------------------------------------------|
| <b>Finding and Recommendations</b>                                                                                                                           | <b>Lead Dept.</b> | <b>Agree, Partially Agree, or Do Not Agree</b> | <b>Expected or Actual Implementation Date</b> | <b>Status of Audit Recommendations, Corrective Action Plan, and Progress Summary</b>                                                                                                                                                                                                                                                                                                                                                                                                                                                                                                                                                           |
|                                                                                                                                                              |                   |                                                |                                               | <p>IT deployed a Cost Allocation plan including Service Level Agreements for all departments in FY 19 and has started collecting data. Starting FY20 IT department will provide annual SLA reporting to the departments.</p> <p>The Cost allocation was presented to all departments with staff from budget office, IT and department managers and fiscal team members. The complete plan was also presented to the Senior Executive Team meeting. The final cost and Service Level agreements were emailed to all departments in June 2018 and the budget was adjusted by budget office to reflect the cost allocation changes for FY 19.</p> |

**Attachment 1:** Audit Status Report: City at Crossroads as Long-Standing Need for Structured Approach to Line of Business Experts Function Intersects with ERP Implementation

| <b>Audit Title: City at crossroads as long-standing need for structured approach to line of business experts function intersects with ERP implementation</b> |                                                                                                                                                                                                                                                                                                                                                                                                                                                                               |                        |                                                                                                              |                                                                                                                                  |                                                                                                                                                                                                                                                                                                                                                                                                                                                                                                                                                                                                                                                                                                                                                     |
|--------------------------------------------------------------------------------------------------------------------------------------------------------------|-------------------------------------------------------------------------------------------------------------------------------------------------------------------------------------------------------------------------------------------------------------------------------------------------------------------------------------------------------------------------------------------------------------------------------------------------------------------------------|------------------------|--------------------------------------------------------------------------------------------------------------|----------------------------------------------------------------------------------------------------------------------------------|-----------------------------------------------------------------------------------------------------------------------------------------------------------------------------------------------------------------------------------------------------------------------------------------------------------------------------------------------------------------------------------------------------------------------------------------------------------------------------------------------------------------------------------------------------------------------------------------------------------------------------------------------------------------------------------------------------------------------------------------------------|
| <b>Finding and Recommendations</b>                                                                                                                           |                                                                                                                                                                                                                                                                                                                                                                                                                                                                               | <b>Lead Dept.</b>      | <b>Agree, Partially Agree, or Do Not Agree</b>                                                               | <b>Expected or Actual Implementation Date</b>                                                                                    | <b>Status of Audit Recommendations, Corrective Action Plan, and Progress Summary</b>                                                                                                                                                                                                                                                                                                                                                                                                                                                                                                                                                                                                                                                                |
| 1.5                                                                                                                                                          | <p>Work with the Human Resources Department to revise the job classification used for the portfolio coordinator position. Minimum qualification factors might include, but are not limited to:</p> <ul style="list-style-type: none"> <li>▪ IT Governance/Portfolio Management experience;</li> <li>▪ Project Management Professional certification;</li> <li>▪ Project coordination experience; and</li> <li>▪ Excellent verbal and written communication skills.</li> </ul> | Information Technology | Agreed (at time of audit issuance 1/24/17); current status is Partially Agree – more study needed at 7/25/17 | <p>TBD, depending on consultant analysis. See status update in next column.</p> <p><b>Status Update 4/23/19: In Progress</b></p> | <p><b>Status at time of audit issuance 1/24/17: In Progress</b><br/>Information Technology department is working with Budget office to find one time budget to hire a consultant to work with Human Resources to review and classify the Information Technology Job Classifications including Application Programmer Analyst (Portfolio Coordinators Role). It will follow the City’s Admin regulation procedures and will need to be approved by Human Resources, Labor, and Personnel Board before changes are effective.</p> <p><b>Status Update 7/25/17: In progress</b><br/>To be implemented with ERP Project Implementation<br/>Any changes to the job classification must follow the City’s Personnel Ordinance and Personnel Rules and</p> |

**Attachment 1:** Audit Status Report: City at Crossroads as Long-Standing Need for Structured Approach to Line of Business Experts Function Intersects with ERP Implementation

| <b>Audit Title: City at crossroads as long-standing need for structured approach to line of business experts function intersects with ERP implementation</b> |                   |                                                |                                               |                                                                                                                                                                                                                                                                                                                                                                                                                                                                                                                                                                                                                                                                                                                               |
|--------------------------------------------------------------------------------------------------------------------------------------------------------------|-------------------|------------------------------------------------|-----------------------------------------------|-------------------------------------------------------------------------------------------------------------------------------------------------------------------------------------------------------------------------------------------------------------------------------------------------------------------------------------------------------------------------------------------------------------------------------------------------------------------------------------------------------------------------------------------------------------------------------------------------------------------------------------------------------------------------------------------------------------------------------|
| <b>Finding and Recommendations</b>                                                                                                                           | <b>Lead Dept.</b> | <b>Agree, Partially Agree, or Do Not Agree</b> | <b>Expected or Actual Implementation Date</b> | <b>Status of Audit Recommendations, Corrective Action Plan, and Progress Summary</b>                                                                                                                                                                                                                                                                                                                                                                                                                                                                                                                                                                                                                                          |
|                                                                                                                                                              |                   |                                                |                                               | <p>Regulations, which require meet and confer with the affected Union and approval by the Personnel Board before the changes are effective. IT no longer fully agrees with the recommendation. IT has re-evaluated the situation. Currently we have 16 Portfolio Coordinators, and not every one of them is involved in the project management activities. Based on the role, some are doing Programming and/or Business Analysis, while a select few are involved in project management. We'll work with HR, CMO and provide future updates after the Consultant evaluation to be scheduled.</p> <p><b>Status Update 4/23 /19: In Progress</b><br/>IT is working with human resources department to release an RFP to do</p> |

**Attachment 1:** Audit Status Report: City at Crossroads as Long-Standing Need for Structured Approach to Line of Business Experts Function Intersects with ERP Implementation

| <b>Audit Title: City at crossroads as long-standing need for structured approach to line of business experts function intersects with ERP implementation</b> |  |                   |                                                |                                               |                                                                                                                                      |  |
|--------------------------------------------------------------------------------------------------------------------------------------------------------------|--|-------------------|------------------------------------------------|-----------------------------------------------|--------------------------------------------------------------------------------------------------------------------------------------|--|
| <b>Finding and Recommendations</b>                                                                                                                           |  | <b>Lead Dept.</b> | <b>Agree, Partially Agree, or Do Not Agree</b> | <b>Expected or Actual Implementation Date</b> | <b>Status of Audit Recommendations, Corrective Action Plan, and Progress Summary</b>                                                 |  |
|                                                                                                                                                              |  |                   |                                                |                                               | classification study in Summer of 2019 and will report back based on the results of the classification study to identify next steps. |  |





Office of the City Manager

## INFORMATION CALENDAR

April 23, 2019

To: Honorable Mayor and Members of the City Council  
 From: Dee Williams-Ridley, City Manager  
 Submitted by: Timothy Burroughs, Director, Planning and Development Department  
 Subject: LPO NOD: 2300 Shattuck Avenue, #LMSAP2019-0001

### INTRODUCTION

The attached Landmarks Preservation Commission Notice of Decision (NOD) is presented to the Mayor and City Council pursuant to Berkeley Municipal Code/Landmarks Preservation Ordinance (BMC/LPO) Section 3.24.240.A, which requires that “a copy of the Notice of Decision shall be filed with the City Clerk, and the City Clerk shall present said copy to the City Council at its next regular meeting.”

### CURRENT SITUATION AND ITS EFFECTS

The Landmark Preservation Commission (LPC/Commission) has approved a Structural Alteration Permit (SAP) for the subject City Landmark property. This action is subject to a 15-day appeal period, which began on April 8, 2019.

### BACKGROUND

BMC/LPO Section 3.24.300 allows City Council to review any action of the Landmarks Preservation Commission in granting or denying a Structural Alteration Permit. In order for Council to review the decision on its merits, Council must appeal the Notice of Decision. To do so, a Council member must move this Information Item to Action and then move to set the matter for hearing on its own. Such action must be taken within 15 days of the mailing of the Notice of Decision, or by April 23, 2019. Such certification to Council shall stay all proceedings in the same manner as the filing of an appeal.

If the Council chooses to appeal the action of the Commission, then a public hearing will be set. The Council must rule on the application within 30 days of closing the hearing, otherwise the decision of the Commission is automatically deemed affirmed.

Unless the Council wishes to review the determination of the Commission and make its own decision, the attached NOD is deemed received and filed.

ENVIRONMENTAL SUSTAINABILITY

Landmark designation provides opportunities for the adaptive re-use and rehabilitation of historic resources within the City. The rehabilitation of these resources, rather than their removal, achieves construction and demolition waste diversion, and promotes investment in existing urban centers.

POSSIBLE FUTURE ACTION

The Council may choose to appeal the decision, in which case it would conduct a public hearing at a future date.

FISCAL IMPACTS OF POSSIBLE FUTURE ACTION

There are no known fiscal impacts associated with this action.

CONTACT PERSON

Fatema Crane, Landmarks Preservation Commission Secretary, Planning and Development, 510-981-7410

Attachments:

1: Notice of Decision – #LMSAP2019-0001 for 2300 Shattuck Avenue



L A N D M A R K S  
P R E S E R V A T I O N  
C O M M I S S I O N

---

N O T I C E O F D E C I S I O N

**DATE OF BOARD DECISION: March 7, 2019**  
**DATE NOTICE MAILED: April 8, 2019**  
**APPEAL PERIOD EXPIRATION: April 23, 2019**  
**EFFECTIVE DATE OF PERMIT (Barring Appeal or Certification): April 24, 2019<sup>1</sup>**

## **2300 Shattuck Avenue**

### **The Corder Building**

**Structural Alteration Permit #LMSAP2019-0001 to install new security fences and gates at the rear of, and to replace all upper-story windows on, a City Landmark building.**

The Landmarks Preservation Commission of the City of Berkeley, after conducting a public hearing, **APPROVED** the Structural Alteration Permit for this project.

**APPLICANT:** Andrea Chelotti, The Bay Architects, 1840B Alcatraz Avenue, Berkeley, CA 94703

**ZONING DISTRICT:** Commercial Downtown/Mixed Use (C-D/MU)

**ENVIRONMENTAL REVIEW STATUS:** Categorically exempt from environmental review pursuant to Section 15331 of the CEQA Guidelines for Historical Resource Rehabilitation.

**The Application materials for this project are available online at:**  
<http://www.cityofberkeley.info/zoningapplications>

---

**FINDINGS, CONDITIONS AND APPROVED PLANS ARE ATTACHED TO THIS NOTICE**

---

<sup>1</sup> Pursuant to BMC Section 1.04.070, if the close of the appeal period falls on a weekend or holiday, then the appeal period expires the following business day. Pursuant to BMC Section 3.24.190, the City Council may “certify” any decision of the LPC for review, within fifteen days from the mailing of the NOD. Such certification shall stay all proceedings in the same manner as the filing of a notice of appeal.

LANDMARKS PRESERVATION COMMISSION  
NOTICE OF DECISION  
LMSAP2019-0001  
2300 Shattuck Avenue  
April 8, 2019  
Page 2 of 4

**COMMISSION VOTE: 8-0-0-0 (one vacancy)**

**YES:** ABRACHAS DA SILVA, ADAMS, ALLEN, CHAGNON, CRANDALL, FINACOM,  
O'MALLEY, SCHWARTZ

**NO:** None

**ABSTAIN:** None

**ABSENT:** None

**TO APPEAL THIS DECISION (see Section 3.24.300 of the Berkeley Municipal Code):**

To appeal a decision of the Landmarks Preservation Commission to the City Council you must:

1. Submit a letter clearly and concisely setting forth the grounds for the appeal to the City Clerk, located at 2180 Milvia Street, 1<sup>st</sup> Floor, Berkeley; or by facsimile to (510) 981-6901. The City Clerk's telephone number is (510) 981-6900.
2. The appeal must be received prior to 5:00 p.m. on the "APPEAL PERIOD EXPIRATION" date shown above (if the close of the appeal period falls on a weekend or holiday, then the appeal period expires the following business day).
3. Submit the required fee (checks and money orders must be payable to 'City of Berkeley'):
  - a. The basic fee for persons other than the applicant is \$500. This fee may be reduced to \$100 if the appeal is signed by persons who lease or own at least 50 percent of the parcels or dwelling units within 300 feet of the project site, or at least 25 such persons (not including dependent children), whichever is less.
  - b. The fee for appeals of affordable housing projects (defined as projects which provide 50 percent or more affordable units for households earning 80% or less of Area Median Income) is \$500, which may not be reduced.
  - c. The fee for all appeals by Applicants is \$2500.

**STRUCTURAL ALTERATION PERMIT ISSUANCE:**

If no appeal is received, the Structural Alteration permit will be issued on the first business day following expiration of the appeal period, and the project may proceed at that time. Information about the Building Permit process can be found at the following link:

<http://www.ci.berkeley.ca.us/permitservicecenter/>.

LANDMARKS PRESERVATION COMMISSION  
NOTICE OF DECISION  
LMSAP2019-0001  
2300 Shattuck Avenue  
April 8, 2019  
Page 3 of 4

**NOTICE CONCERNING YOUR LEGAL RIGHTS:**

---

If you object to this decision, the following requirements and restrictions apply:

1. If you challenge this decision in court, you may be limited to raising only those issues you or someone else raised at the public hearing described in this notice, or in written correspondence delivered to the Landmarks Preservation Commission at, or prior to, the public hearing.
2. You must appeal to the City Council within fifteen (15) days after the Notice of Decision of the action of the Landmarks Preservation Commission is mailed. It is your obligation to notify the Land Use Planning Division in writing of your desire to receive a Notice of Decision when it is completed.
3. Pursuant to Code of Civil Procedure Section 1094.6(b) and Government Code Section 65009(c)(1), no lawsuit challenging a City Council decision, as defined by Code of Civil Procedure Section 1094.6(e), regarding a use permit, variance or other permit may be filed more than ninety (90) days after the date the decision becomes final, as defined in Code of Civil Procedure Section 1094.6(b). Any lawsuit not filed within that ninety (90) day period will be barred.
4. Pursuant to Government Code Section 66020(d)(1), notice is hereby given to the applicant that the 90-day protest period for any fees, dedications, reservations, or other exactions included in any permit approval begins upon final action by the City, and that any challenge must be filed within this 90-day period.
5. If you believe that this decision or any condition attached to it denies you any reasonable economic use of the subject property, was not sufficiently related to a legitimate public purpose, was not sufficiently proportional to any impact of the project, or for any other reason constitutes a "taking" of property for public use without just compensation under the California or United States Constitutions, your appeal of this decision must include the following information:
  - A. That this belief is a basis of your appeal.
  - B. Why you believe that the decision or condition constitutes a "taking" of property as set forth above.
  - C. All evidence and argument in support of your belief that the decision or condition constitutes a "taking" as set forth above.

If you do not do so, you will waive any legal right to claim that your property has been taken, both before the City Council and in court.

LANDMARKS PRESERVATION COMMISSION  
NOTICE OF DECISION  
LMSAP2019-0001  
2300 Shattuck Avenue  
April 8, 2019  
Page 4 of 4

**PUBLIC COMMENT:**

Communications to Berkeley boards, commissions or committees are public record and will become part of the City's electronic records, which are accessible through the City's website. **Please note: e-mail addresses, names, addresses, and other contact information are not required, but if included in any communication to a City board, commission or committee, will become part of the public record.** If you do not want your e-mail address or any other contact information to be made public, you may deliver communications via U.S. Postal Service or in person to the secretary of the relevant board, commission or committee. If you do not want your contact information included in the public record, please do not include that information in your communication. Please contact the secretary to the relevant board, commission or committee for further information.

**FURTHER INFORMATION:**

Questions about the project should be directed to the project planner, Fatema Crane, at (510) 981-7410 or fcrane@cityofberkeley.info. All project application materials, including full-size plans, may be viewed at the Permit Service Center (Zoning counter), 2120 Milvia Street, between 8 a.m. and 4 p.m., Monday through Friday.

**ATTACHMENTS:**

1. Approved Findings and Conditions
2. Project Plans, received **JANUARY 9, 2019**

ATTEST:   
Fatema Crane, Secretary  
Landmarks Preservation Commission

cc: City Clerk  
Applicant: Andrea Chelotti  
The Bay Architects  
1840B Alcatraz Avenue  
Berkeley, CA 94703  
  
Owner: Jay Lakireddy  
2278 Shattuck Avenue  
Berkeley, CA 94703

# ATTACHMENT 1

---

## FINDINGS AND CONDITIONS

### **2300 Shattuck Avenue The Corder Building**

#### **Structural Alteration Permit LMSAP#2019-0001**

**To install new security fences and gates at the rear of, and to replace all upper-story windows on, a City Landmark building.**

#### **CEQA FINDINGS**

---

1. The project is categorically exempt from the provisions of the California Environmental Quality Act (CEQA, Public Resources Code §21000, et seq. and California Code of Regulations, §15000, et seq.) pursuant to Section 15331 of the CEQA Guidelines (“Historic Resource Restoration/Rehabilitation”). Furthermore, none of the exceptions in CEQA Guidelines Section 15300.2 apply, as follows: (a) the site is not located in an environmentally sensitive area, (b) there are no cumulative impacts, (c) there are no significant effects, (d) the project is not located near a scenic highway, (e) the project site is not located on a hazardous waste site pursuant to Government Code Section 65962.5, and (f) the project will not cause a substantial adverse change to the significance of a historical resource.

#### **SECRETARY OF THE INTERIOR’S STANDARDS FINDINGS**

---

Regarding the Secretary of the Interior’s Standards for Rehabilitation, the Landmarks Preservation Commission of the City of Berkeley makes the following findings:

1. This property will be used as it was historically with no change to its distinctive materials, features, spaces, and spatial relationships.
2. The historic character of this property will be retained and preserved. The removal of distinctive materials or alteration of features, spaces, and spatial relationships that characterize this property has been avoided in the approved design.
3. This property will continue to be recognized as a physical record of its time, place, and use as a result of the approved project. No changes that would create a false sense of historical development, such as adding conjectural features or elements from other historic properties, will be undertaken.
4. No changes to this property that have acquired historic significance in their own right are proposed.
5. This project will not affect distinctive materials, features, finishes, and construction techniques or examples of craftsmanship that characterize this property. The

proposed window replacement is limited to deteriorated window sashes, which will be replaced with sashes of a similar design.

6. Any deteriorated historic features will be repaired rather than replaced. Where the severity of deterioration requires replacement of a distinctive feature, the new feature will match the old in design, color, texture, and, where possible, materials. No replacement of missing features will occur and, therefore, no documentary and physical evidence will be required.
7. Chemical or physical treatments, if appropriate, would be undertaken using the gentlest means possible as a condition of this permit, though none are anticipated with this project.
8. Any archeological resources at this site will be unaffected by the proposed work which includes no excavation.
9. Exterior alterations, or related new construction will not destroy historic features, significant amounts of historic materials, or the spatial relationships that characterize the property. The new work (e.g. fence and gate installation) will be differentiated from the old and will be compatible with the historic materials, features, size, scale and proportion, and massing to protect the integrity of the property and its environment.
10. New additions and adjacent or related new construction (e.g. fence and gate installation) will be undertaken in such a manner that, if removed in the future, the essential form and integrity of the historic property and its environment would be unimpaired.

#### **LANDMARK PRESERVATION ORDINANCE FINDINGS**

---

1. As required by Section 3.24.260 of the Landmarks Preservation Ordinance, the Commission finds that proposed work is appropriate for and consistent with the purposes of the Ordinance, and will preserve and enhance the characteristics and features specified in the designation for this property. Specifically:
  - The proposed installation of new fences and gates at the rear of the property will not result permanent or irreparable damage to the Coder Building. These new security features are designed with differentiated materials and muted color(s), and are modest in scale. Owing to these qualities, this project will no adversely affect the exterior architectural features, special character, or the special historical, architectural and aesthetic interests and value of this City Landmark building.



## STANDARD CONDITIONS

---

The following conditions, as well as all other applicable provisions of the Landmarks Preservation Ordinance, apply to this Permit:

### 1. Conditions Shall be Printed on Plans

The conditions of this Permit shall be printed on the *second* sheet of each plan set submitted for a building permit pursuant to this Permit, under the title 'Structural Alteration Permit Conditions'. *Additional sheets* may also be used if the *second* sheet is not of sufficient size to list all of the conditions. The sheet(s) containing the conditions shall be of the same size as those sheets containing the construction drawings; 8-1/2" by 11" sheets are not acceptable.

### 2. Plans and Representations Become Conditions

Except as specified herein, the site plan, floor plans, building elevations and/or any additional information or representations, whether oral or written, indicating the proposed structure or manner of operation submitted with an application or during the approval process are deemed conditions of approval.

### 3. Subject to All Applicable Laws and Regulations

The approved use and/or construction is subject to, and shall comply with, all applicable City Ordinances and laws and regulations of other governmental agencies. Prior to construction, the applicant shall identify and secure all applicable permits from the Zoning Adjustments Board or Zoning Officer, Building and Safety Division, Public Works Department and other affected City divisions and departments.

### 4. Exercise and Lapse of Permits (Section 23B.56.100)

- B. A permit for the construction of a building or structure is deemed exercised when a valid City building permit, if required, is issued, and construction has lawfully commenced.
- A. A permit may be declared lapsed and of no further force and effect if it is not exercised within one year of its issuance, except that permits for construction or alteration of structures or buildings may not be declared lapsed if the permittee has:
  - (1) applied for a building permit; or,
  - (2) made substantial good faith efforts to obtain a building permit and begin construction, even if a building permit has not been issued and/or construction has not begun.

### 5. Indemnification Agreement

The applicant shall hold the City of Berkeley and its officers harmless in the event of any legal action related to the granting of this Permit, shall cooperate with the City in defense of such action, and shall indemnify the City for any award of damages or attorneys fees that may result.

**ADDITIONAL CONDITIONS**

---

The following additional conditions are attached to this Permit:

6. **Chemical Treatments.** Any chemical treatments needed as construction progresses will be undertaken using the gentlest means possible.
7. **Landscape and planting elements.** Prior to submittal of any building permit for this project, the applicant shall revise the project plans to include landscape screening and plantings adjacent to Durant Avenue public right-of-way (south) and the abutting property at 2037 Durant (west), in accordance with the Downtown Berkeley Design Guidelines (2012) for *Parking Lots* and in alignment with Berkeley Municipal Code Section 23E.28.070.D and E for Location and Screening of *Parking Spaces and Driveways*.
8. **Automatic landscape irrigation.** Prior to submittal of any building permit for this project, the applicant shall prepare and submit project plans that include automatic irrigation for the new, required planting areas.
9. **Final window design.** Prior to submittal of any building permit for this project, the applicant shall submit revised project plans that include: 1) clear glazing for all windows on the north, east and south facades; and 2) new windows to match the existing style and details, including ogees. The applicant shall provide a sample or model window for final approval by staff.
10. **Administrative Use Permit approval.** Prior to submittal of any building permit for this project, the applicant shall obtain an Administrative Use Permit for, at a minimum, the proposed fence located on a property line which exceeds six feet in height (Berkeley Municipal Code Section 23E.04.040 – *Fences and Other Unenclosed Accessory Structures*).
11. **Traffic Engineering review.** Prior to issuance of any building permit for this project, the applicant shall obtain plan check approval by the City's Traffic Engineer (TE) to determine compliance with the TE's minimum safety and engineering standards.

**AT ALL TIMES**

12. **Irrigated, water efficient landscape.** The property owner shall maintain automatic irrigation and drainage facilities adequate to assure healthy growing conditions for all required planting and landscape. The landscape shall be drought-tolerant, where appropriate, and achieve maximum water efficiency.

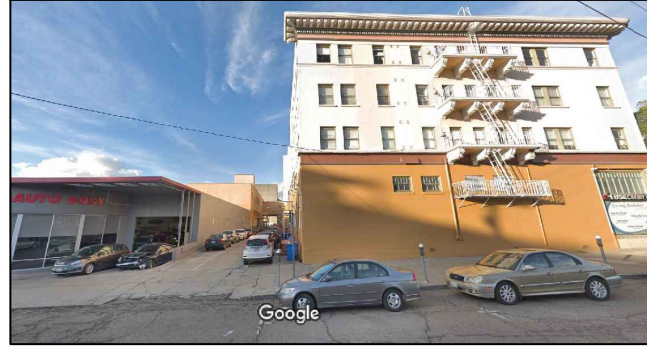

EXISTING DURANT AVENUE ELEVATION (9) NTS



EXISTING SHATTUCK AVENUE ELEVATION (6) NTS



EXISTING BANCROFT WAY ELEVATION (3) NTS

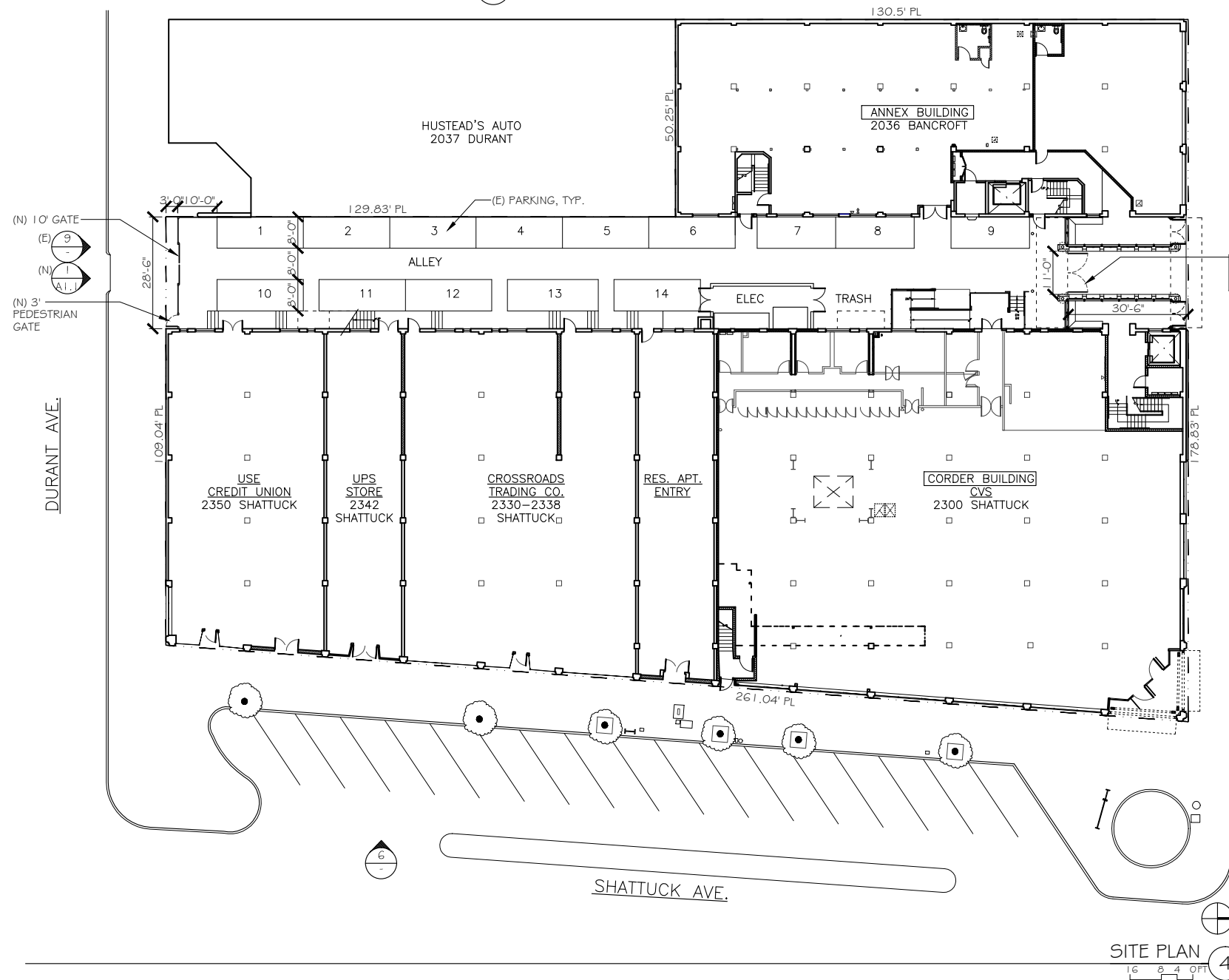

SITE PLAN (4) NTS

ZONING / LPC INFORMATION

THE CORDER BUILDING, CITY OF BERKELEY LANDMARK #44 (1981)  
C-DMU CORRIDOR ZONING DISTRICT  
37,515 SF LOT  
THE CORDER BUILDING IS A CITY LANDMARK #44, DESIGNATED IN 1981, AND IT IS ALSO LISTED ON THE NATIONAL REGISTRY OF HISTORIC PLACES. THE FIRST FLOOR WAS CONSTRUCTED IN 1921, AND THE UPPER RESIDENTIAL FLOORS WERE ADDED IN 1926. A REAR, THREE STORY BUILDING KNOWN AS THE ANNEX WAS CONSTRUCTED SOMETIME IN THE 1930S ALONG BANCROFT WAY AND PARALLEL TO AN ALLEY IMMEDIATELY BEHIND THE CORDER. A PEDESTRIAN BRIDGE LINKS THE CORDER'S SECOND AND THE ANNEX'S THIRD FLOORS.

PROJECT DESCRIPTION

THE CORDER BUILDING IS A 4-STORY BUILDING CONTAINING 3 FLOORS OF RESIDENTIAL APARTMENTS & OFFICES ABOVE GROUND FLOOR RETAIL. THE ANNEX BUILDING IS A 3-STORY COMMERCIAL/OFFICE BUILDING. BEHIND THE CORDER BUILDING THERE IS A PRIVATE THROUGH-BLOCK ALLEY SPANNING FROM BANCROFT TO DURANT THAT PROVIDES PARKING FOR TENANTS. THE OWNERS HAVE HAD NUMEROUS TRESPASSING AND SECURITY ISSUES IN THE ALLEY AND THEREFORE PROPOSE INSTALLATION OF VEHICLE AND PEDESTRIAN GATES TO CONTROL ACCESS. THE GATES WILL ALSO ALLOW EGRESS FROM BOTH BUILDINGS. IN ADDITION, WINDOWS WILL BE REPLACED ON THE 2ND-4TH FLOORS OF THE CORDER BUILDING.

SCOPE OF WORK

1. NEW GATE AT BANCROFT: FOR COMBINED VEHICLE ACCESS AND PEDESTRIAN EGRESS.
2. NEW GATE AT DURANT: SEPARATE VEHICLE GATE AND PEDESTRIAN EGRESS GATE.
3. WINDOW REPLACEMENT AT THE CORDER BUILDING'S 2ND-4TH FLOORS.

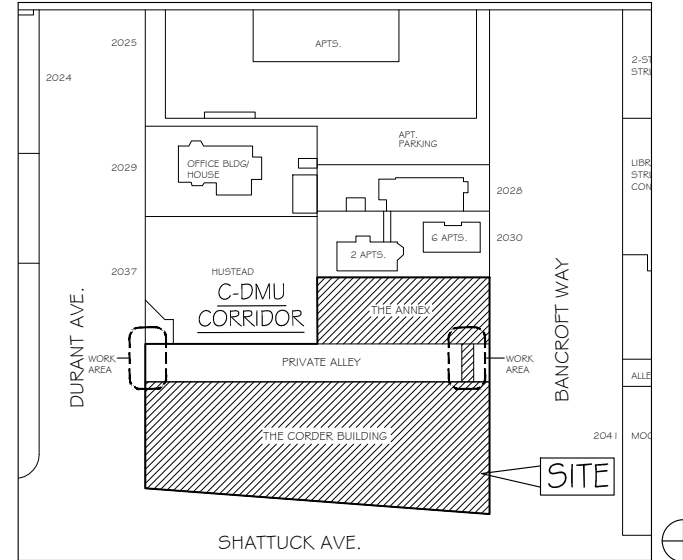

VICINITY MAP (1) NTS



PROJECT:  
**NEW ALLEY GATES & WINDOW REPLACEMENT AT THE CORDER BUILDING**  
2300 SHATTUCK AVENUE  
BERKELEY, CA 94704  
APN: 055 189401704

ARCHITECT OF RECORD:  
JAMES NOVOSEL

the bay architects  
1840b alcatraz ave  
berkeley, ca 94703  
510.420.1484  
fax 510.420.1165  
www.bayarch.com  
bayarch@pacbell.net  
COPYRIGHT: DEC. 2018  
THE BAY ARCHITECTS

OWNER/CLIENT:  
2322 SHATTUCK LLC  
2278 SHATTUCK AVENUE  
BERKELEY, CA 94704  
(510)549-1954  
CONTACT: LAKSH LAKIREDDY

PRINT DATE / PURPOSE  
12/12/18 LPC STRUCT. ALT. PERMIT

COVER SHEET  
**AO. I**  
DRAWING SHEET

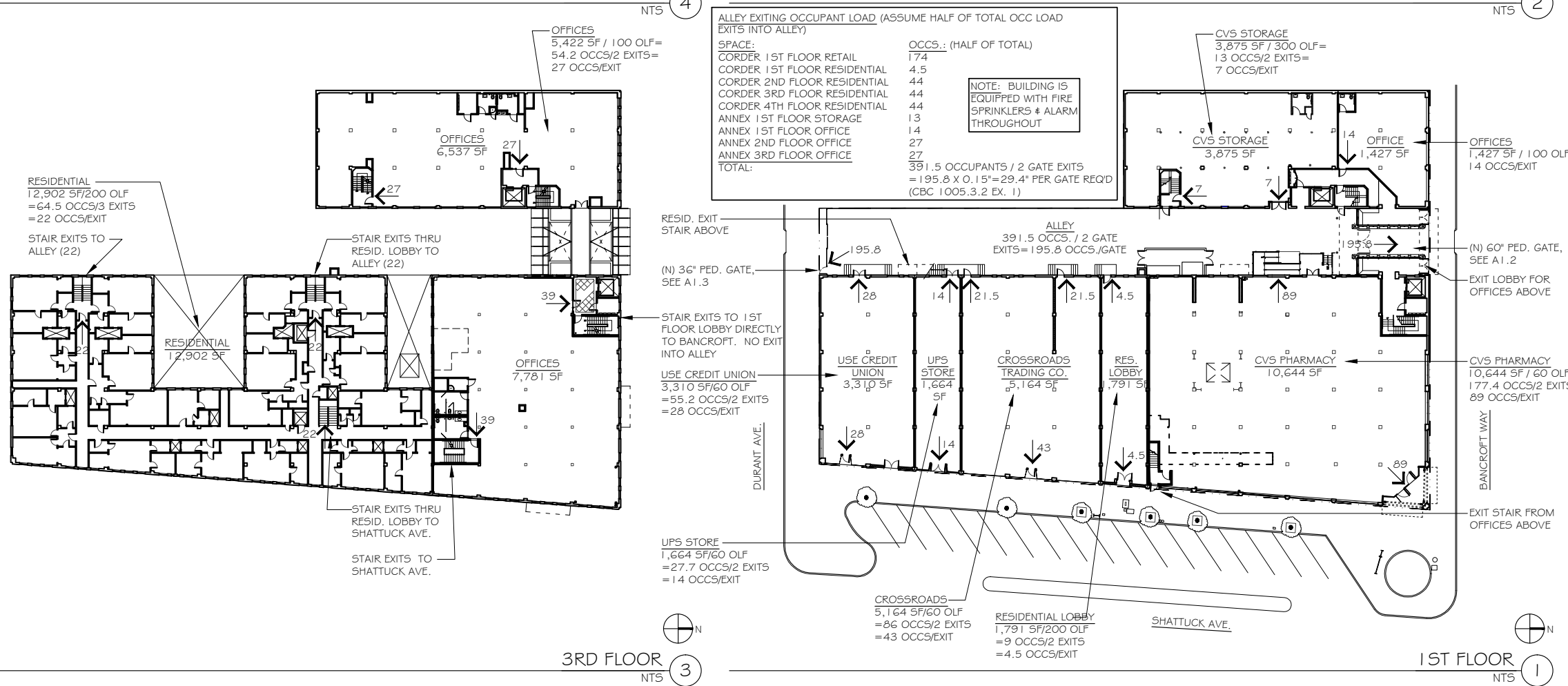
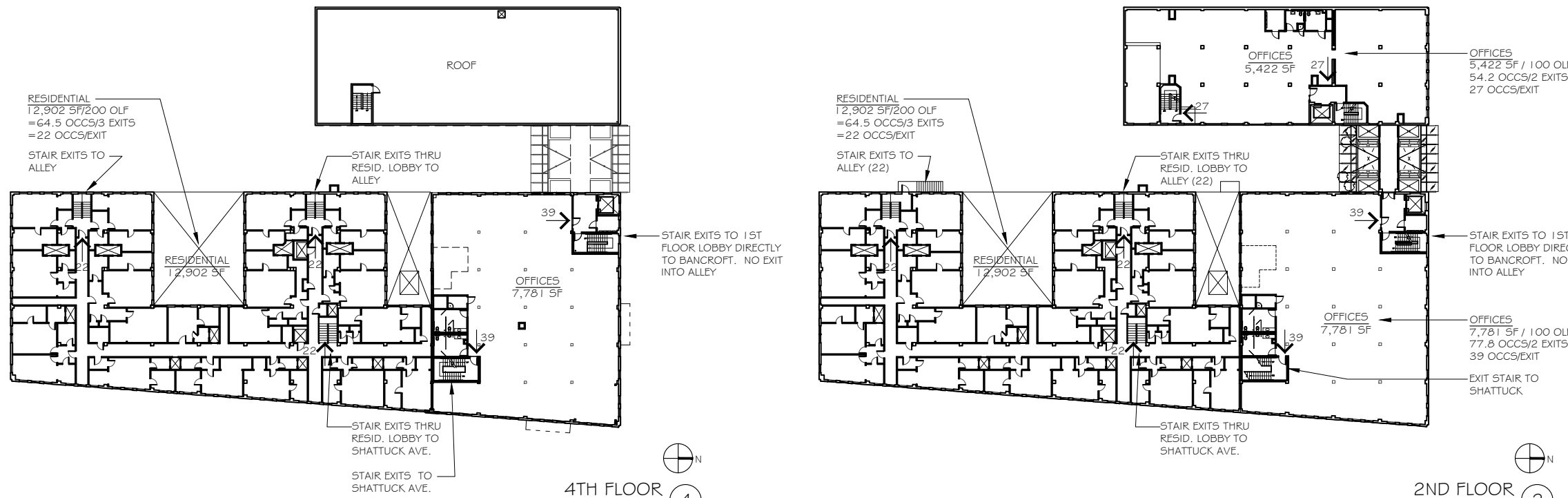

ALLEY EXITING OCCUPANT LOAD (ASSUME HALF OF TOTAL OCC LOAD EXITS INTO ALLEY)

| SPACE:                       | OCCS.: (HALF OF TOTAL)                                                                            |
|------------------------------|---------------------------------------------------------------------------------------------------|
| CORDER 1ST FLOOR RETAIL      | 174                                                                                               |
| CORDER 1ST FLOOR RESIDENTIAL | 4.5                                                                                               |
| CORDER 2ND FLOOR RESIDENTIAL | 44                                                                                                |
| CORDER 3RD FLOOR RESIDENTIAL | 44                                                                                                |
| CORDER 4TH FLOOR RESIDENTIAL | 44                                                                                                |
| ANNEX 1ST FLOOR STORAGE      | 13                                                                                                |
| ANNEX 1ST FLOOR OFFICE       | 14                                                                                                |
| ANNEX 2ND FLOOR OFFICE       | 27                                                                                                |
| ANNEX 3RD FLOOR OFFICE       | 27                                                                                                |
| <b>TOTAL:</b>                | <b>391.5 OCCUPANTS / 2 GATE EXITS = 195.8 X 0.15" = 29.4" PER GATE REQ'D (CBC 1005.3.2 EX. 1)</b> |

NOTE: BUILDING IS EQUIPPED WITH FIRE SPRINKLERS & ALARM THROUGHOUT

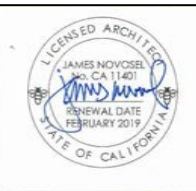

PROJECT:  
**NEW ALLEY GATES & WINDOW REPLACEMENT AT THE CORDER BUILDING**  
2300 SHATTUCK AVENUE  
BERKELEY, CA 94704  
APN: 055 189401704

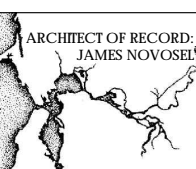

ARCHITECT OF RECORD:  
JAMES NOVOSSEL

**the bay architects**  
1840b alcatraz ave  
berkeley, ca 94703  
510.420.1484  
fax 510.420.1165  
www.bayarch.com  
bayarch@pacbell.net  
COPYRIGHT: DEC 2018  
THE BAY ARCHITECTS

OWNER/CLIENT:  
2322 SHATTUCK LLC  
2278 SHATTUCK AVENUE  
BERKELEY, CA 94704  
(510)549-1954  
CONTACT: LAKSH LAKIREDDY

PRINT DATE / PURPOSE  
12/12/18 LPC STRUCT. ALT. PERMIT

EXITING CODE ANALYSIS  
**A0.2**  
DRAWING SHEET



PROPOSED BANCROFT ELEVATION 2

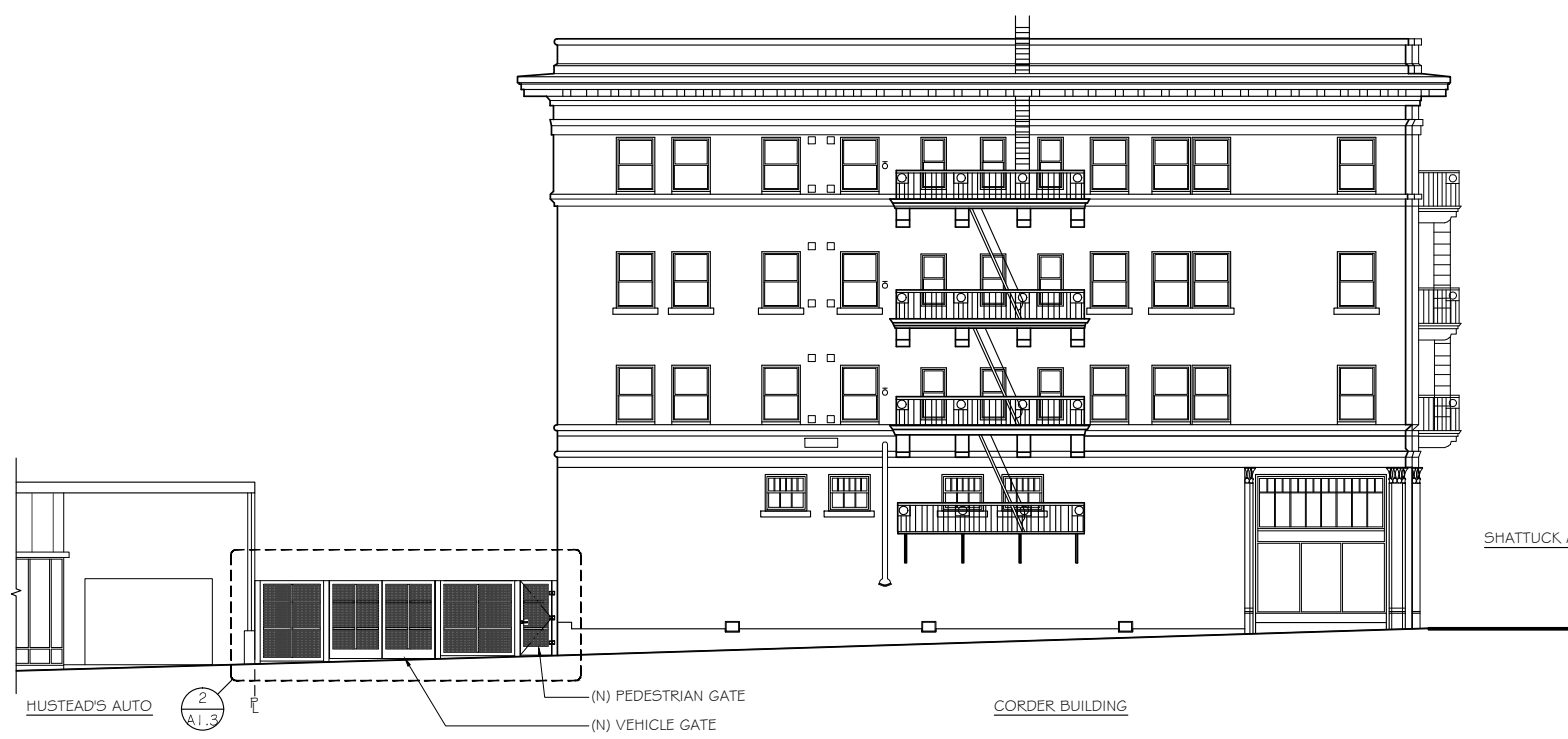

PROPOSED DURANT ELEVATION 1

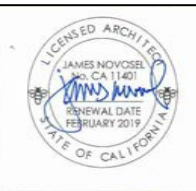

PROJECT:  
**NEW ALLEY GATES & WINDOW REPLACEMENT AT THE CORDER BUILDING**  
2300 SHATTUCK AVENUE  
BERKELEY, CA 94704  
APN: 055 189401704

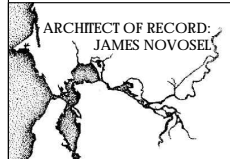

ARCHITECT OF RECORD:  
JAMES NOVOSSEL  
**the bay architects**  
1840b alcatraz ave  
berkeley, ca 94703  
510.420.1484  
fax 510.420.1165  
www.bayarch.com  
bayarch@pacbell.net  
COPYRIGHT: DEC 2018  
THE BAY ARCHITECTS

OWNER/CLIENT:  
2322 SHATTUCK LLC  
2278 SHATTUCK AVENUE  
BERKELEY, CA 94704  
(510)549-1954  
CONTACT: LAKSH LAKIREDDY

PRINT DATE / PURPOSE  
12/12/18 LPC STRUCT. ALT. PERMIT

PROPOSED GATE ELEVATIONS  
**AI.1**  
DRAWING SHEET

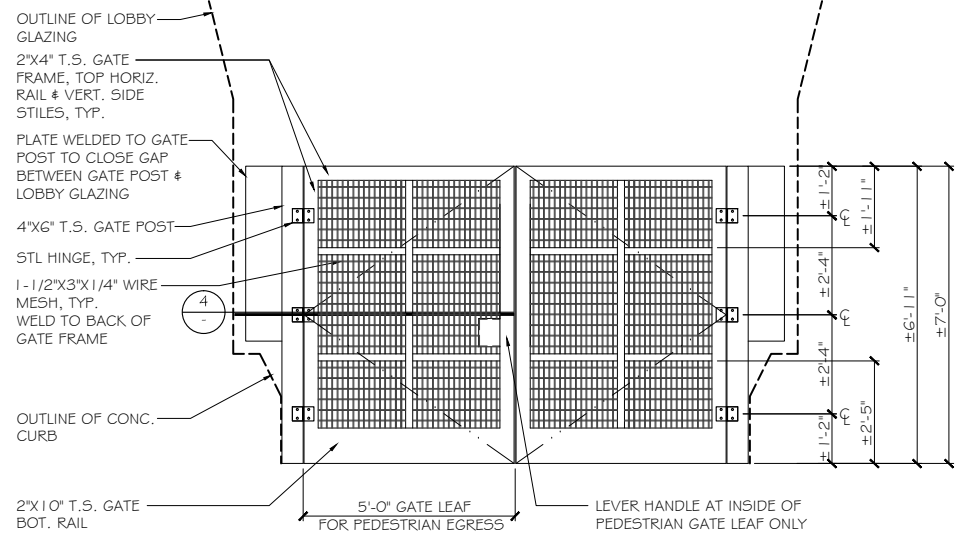

METAL GATE DETAIL & DIMENSIONS (6)

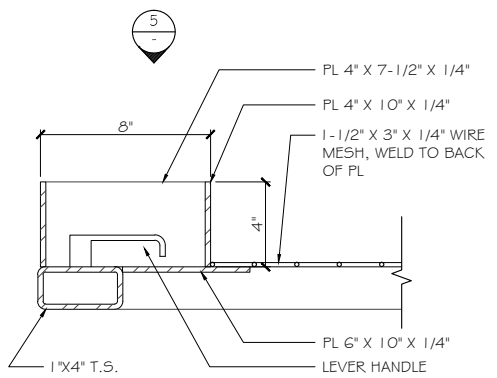

HANDLE GUARD - PLAN (8)

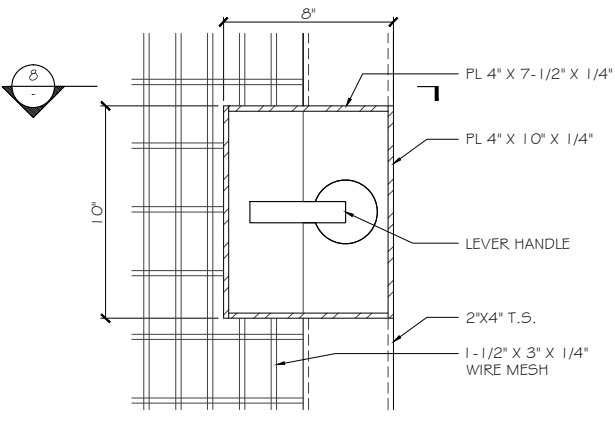

HANDLE GUARD - ELEV (5)

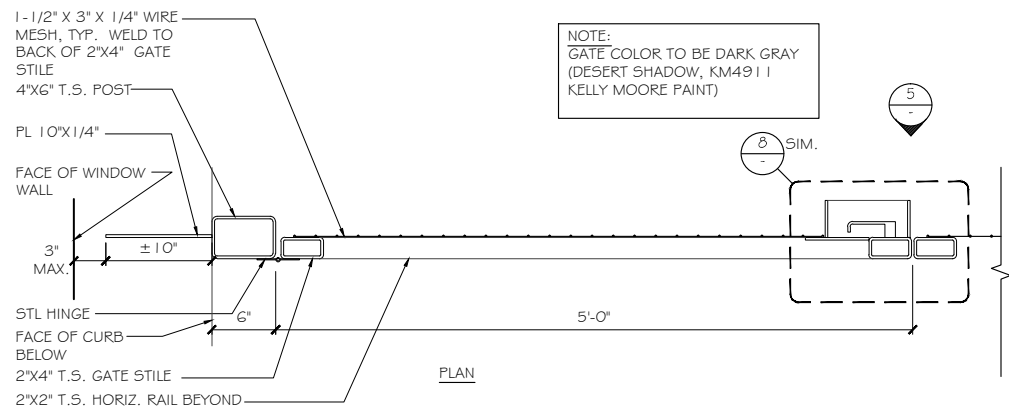

GATE DETAIL (4)

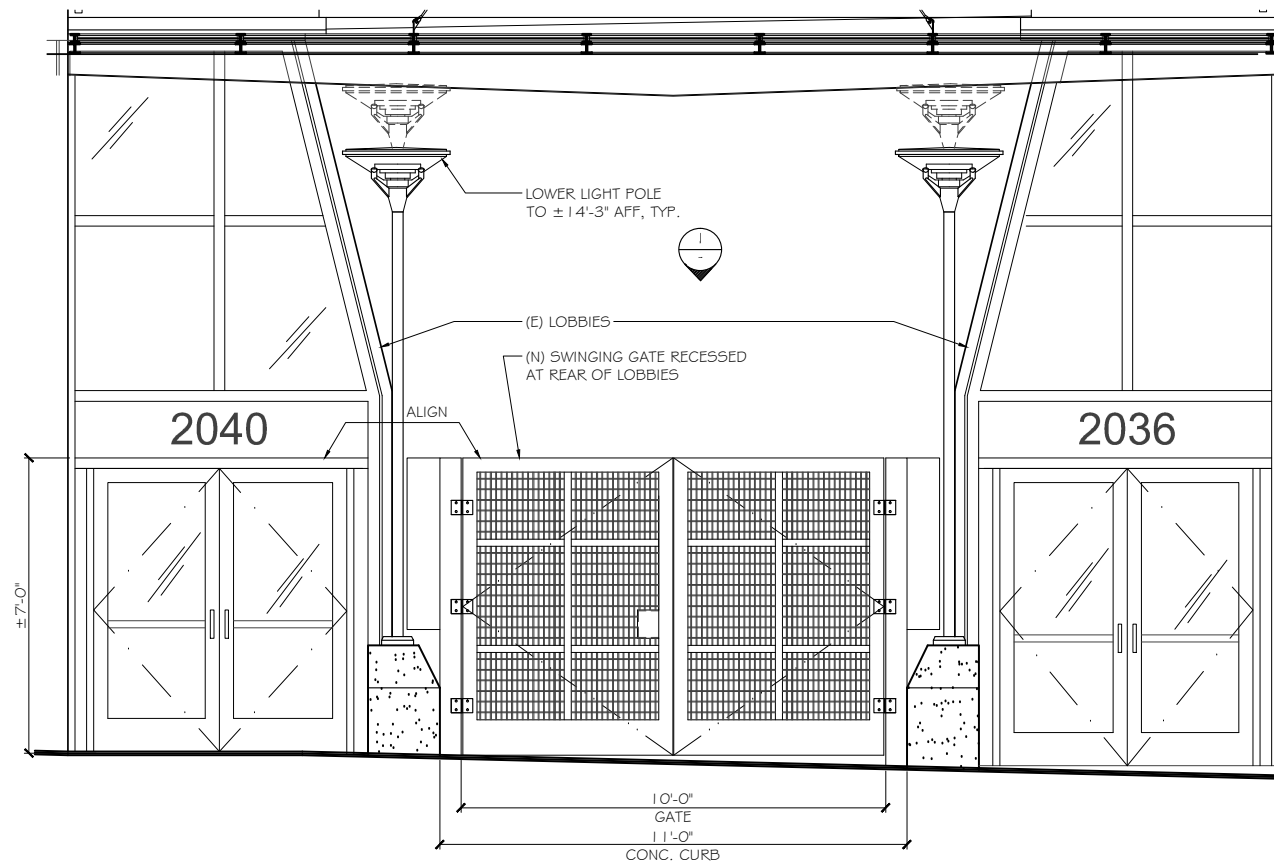

BANCROFT GATE ELEVATION (2)

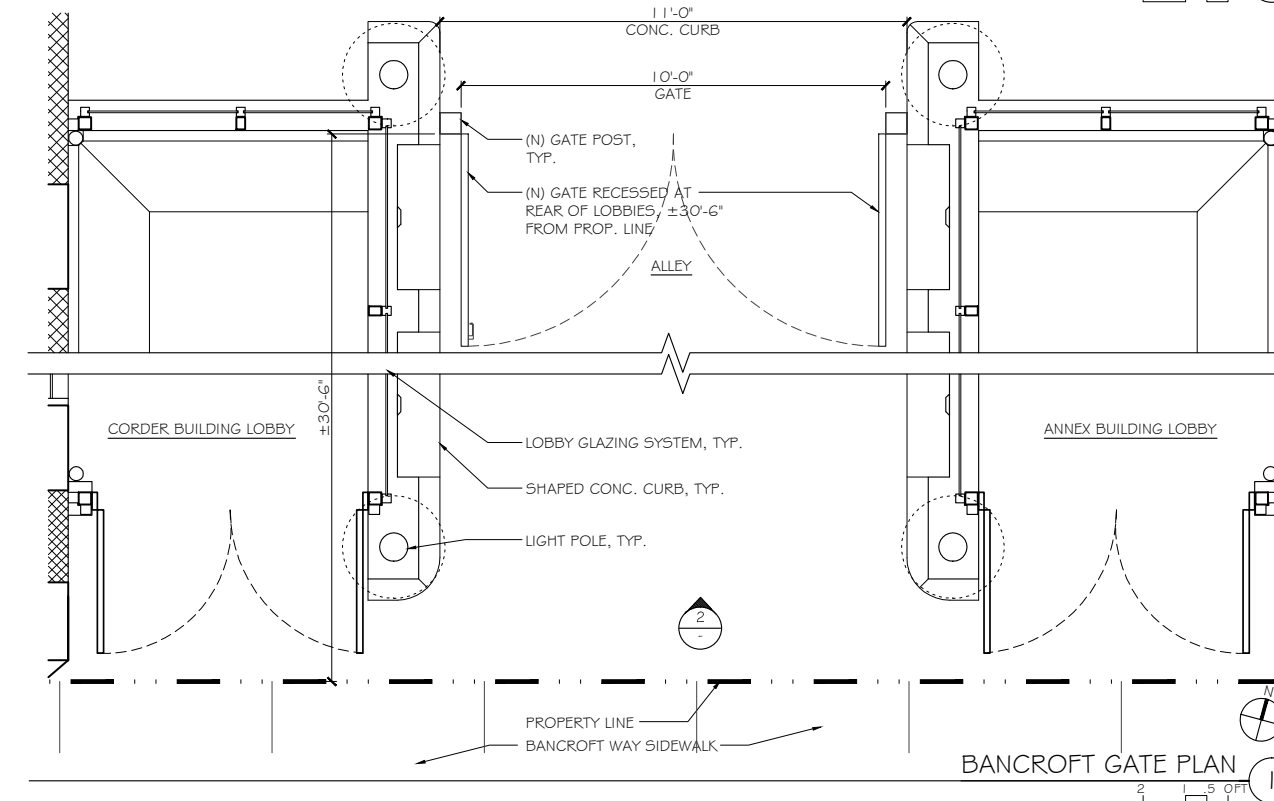

BANCROFT GATE PLAN (1)



PROJECT:  
**NEW ALLEY GATES & WINDOW REPLACEMENT AT THE CORDER BUILDING**  
2300 SHATTUCK AVENUE  
BERKELEY, CA 94704  
APN: 055 189401704

ARCHITECT OF RECORD:  
JAMES NOVOSEL  
**the bay architects**  
1840b alcatraz ave  
berkeley, ca 94703  
510.420.1484  
fax 510.420.1165  
www.bayarch.com  
bayarch@pacbell.net  
COPYRIGHT: DEC 2018  
THE BAY ARCHITECTS

OWNER/CLIENT:  
2322 SHATTUCK LLC  
2278 SHATTUCK AVENUE  
BERKELEY, CA 94704  
(510)549-1954  
CONTACT: LAKSH LAKIREDDY

PRINT DATE / PURPOSE  
12/12/18 LPC STRUCT. ALT. PERMIT

BANCROFT GATE PLAN & ELEVATIONS  
**A1.2**  
DRAWING SHEET

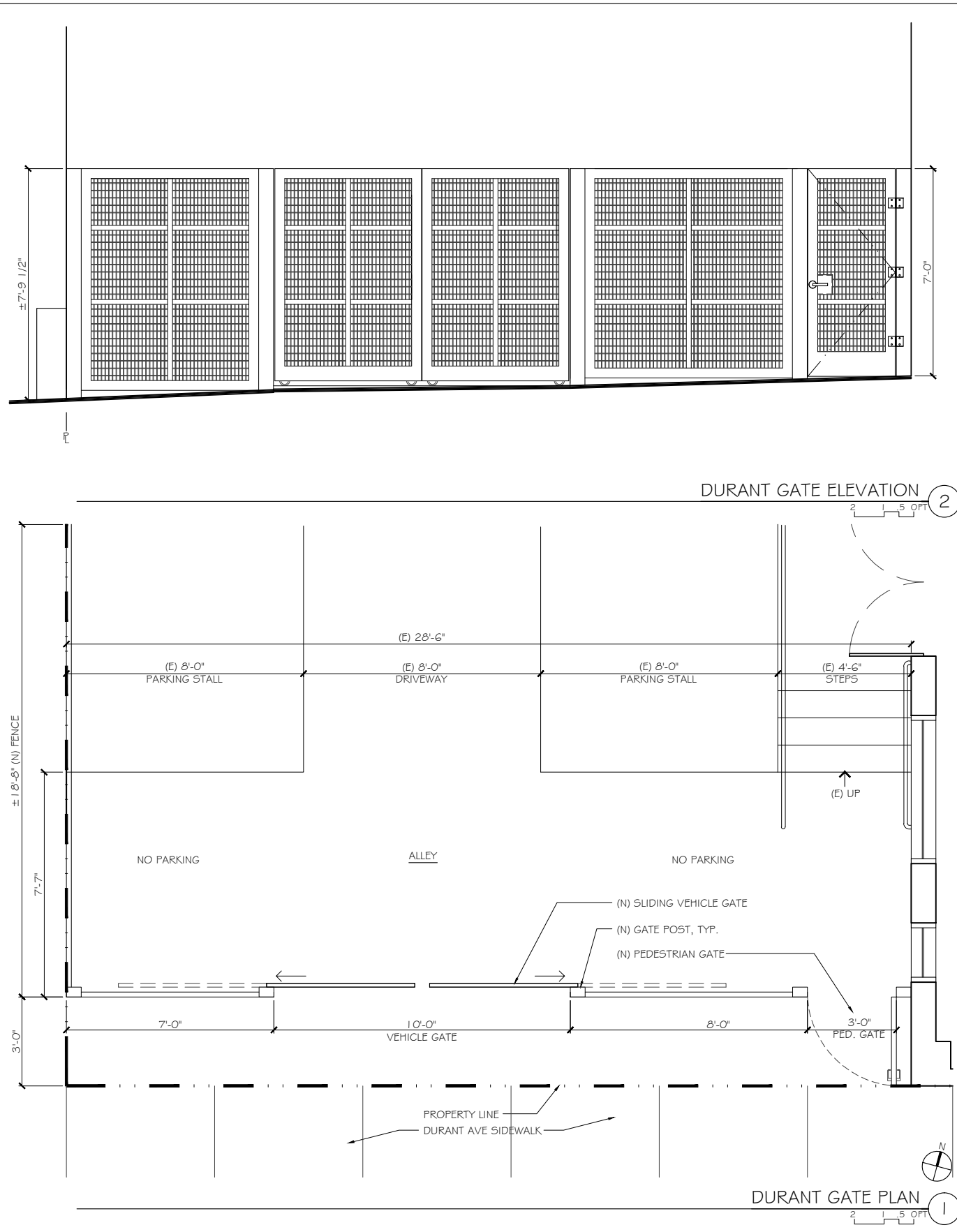
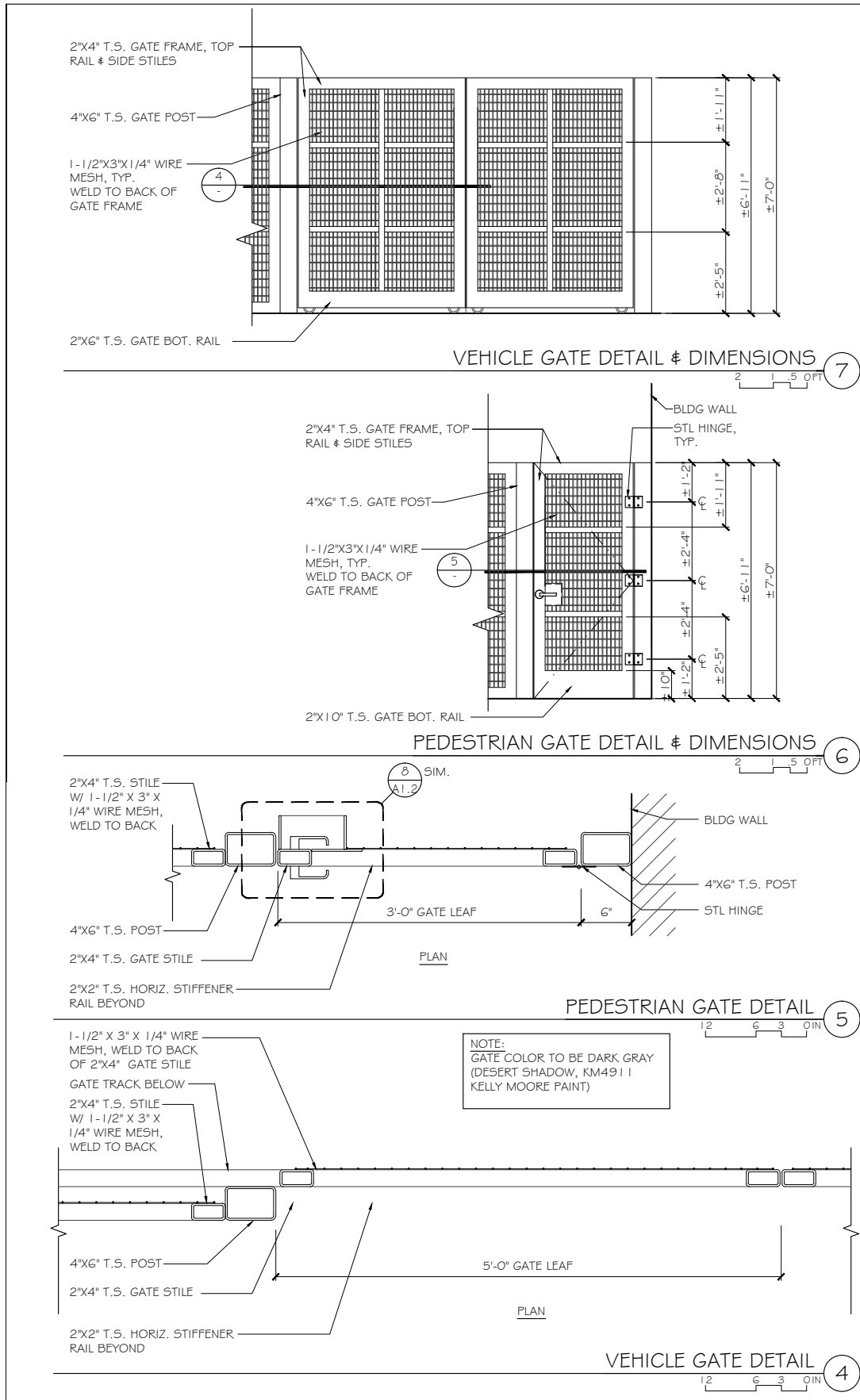

LICENSED ARCHITECT  
 JAMES NOVOSEL  
 No. CA 11497  
 RENEWAL DATE FEBRUARY 2019  
 STATE OF CALIFORNIA

PROJECT:  
**NEW ALLEY GATES & WINDOW REPLACEMENT AT THE CORDER BUILDING**  
 2300 SHATTUCK AVENUE  
 BERKELEY, CA 94704  
 APN: 055 189401704

ARCHITECT OF RECORD:  
 JAMES NOVOSEL

**the bay architects**  
 1840b alcatraz ave  
 berkeley, ca 94703  
 510.420.1484  
 fax 510.420.1165  
 www.bayarch.com  
 bayarch@pacbell.net  
 COPYRIGHT: DEC 2018  
 THE BAY ARCHITECTS

OWNER/CLIENT:  
 2322 SHATTUCK LLC  
 2278 SHATTUCK AVENUE  
 BERKELEY, CA 94704  
 (510)549-1954  
 CONTACT: LAKSH LAKIREDDY

PRINT DATE / PURPOSE  
 12/12/18 LPC STRUCT. ALT. PERMIT

DURANT GATE PLAN & ELEVATIONS  
**A1.3**  
 DRAWING SHEET

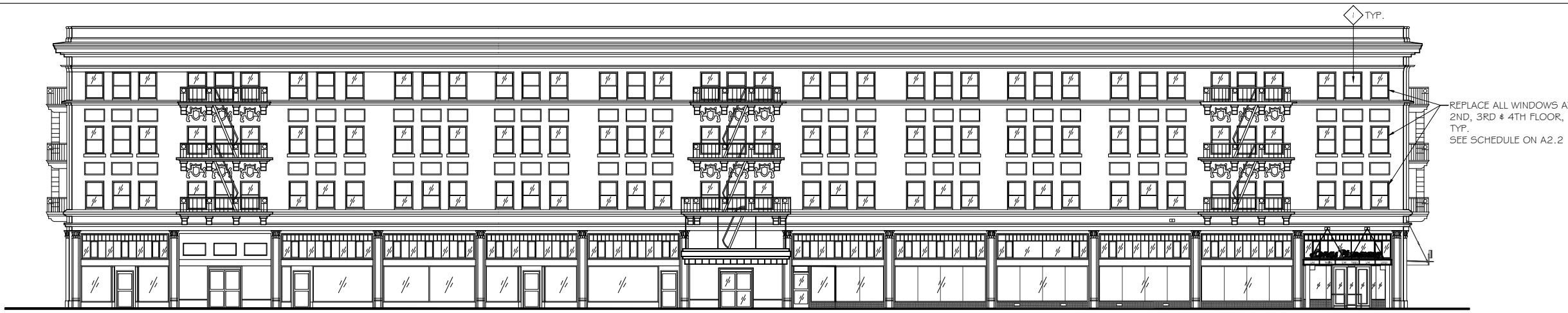

SHATTUCK AVENUE (EAST) ELEVATION 3

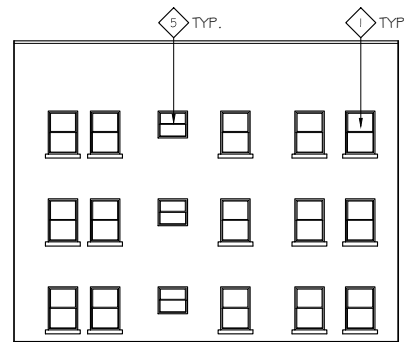

TYP. LIGHTWELL ELEV. 8

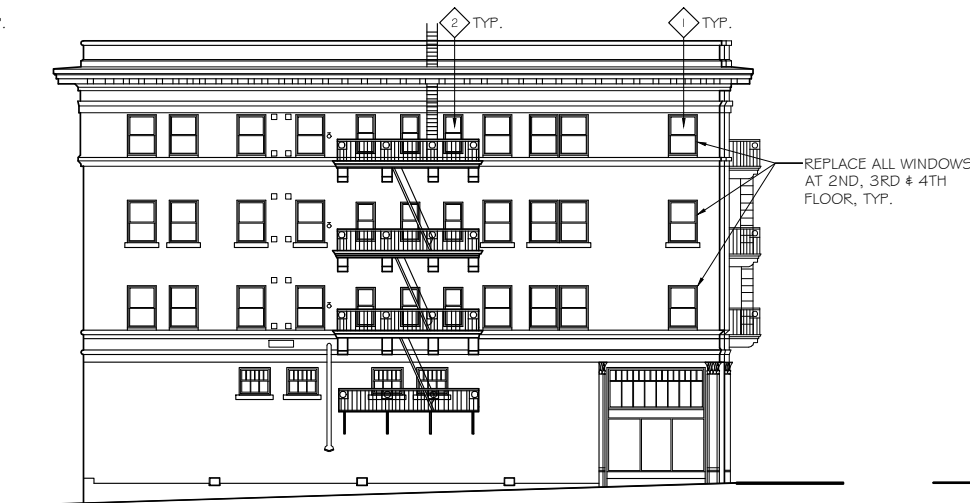

DURANT AVENUE (SOUTH) ELEVATION 5

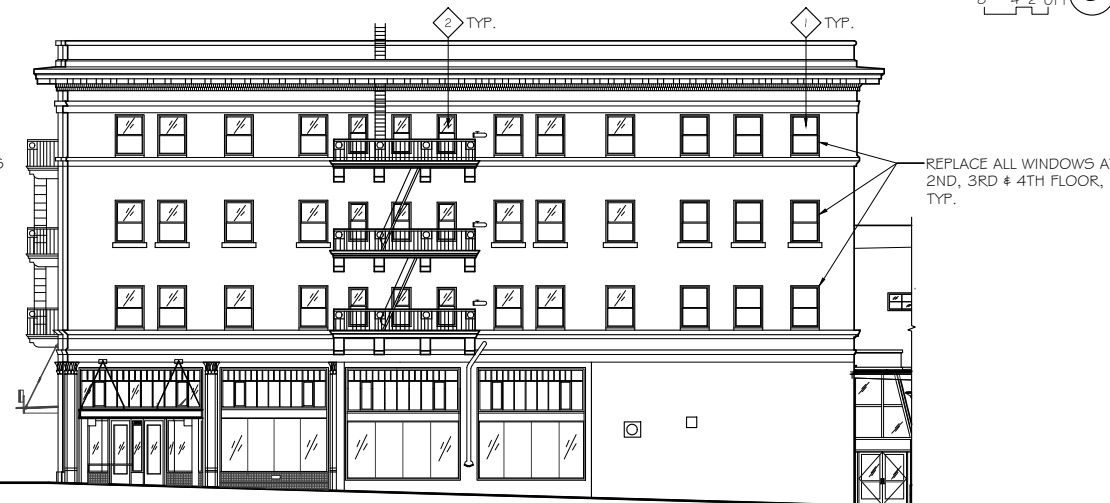

BANCROFT WAY (NORTH) ELEVATION 2



ALLEY (WEST) ELEVATION 1

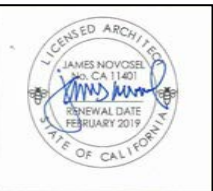

PROJECT:  
**NEW ALLEY GATES & WINDOW REPLACEMENT AT THE CORDER BUILDING**  
2300 SHATTUCK AVENUE  
BERKELEY, CA 94704  
APN: 055 189401704

ARCHITECT OF RECORD:  
JAMES NOVOSSEL  
**the bay architects**  
1840b alcatraz ave  
berkeley, ca 94703  
510.420.1484  
fax 510.420.1165  
www.bayarch.com  
bayarch@pacbell.net  
COPYRIGHT: DEC. 2018  
THE BAY ARCHITECTS

OWNER/CLIENT:  
2322 SHATTUCK LLC  
2278 SHATTUCK AVENUE  
BERKELEY, CA 94704  
(510)549-1954  
CONTACT: LAKSH LAKIREDDY

PRINT DATE / PURPOSE  
12/12/18 LPC STRUCT. ALT. PERMIT

ELEVATIONS FOR WINDOW REPLACEMENT  
**A2.1**  
DRAWING SHEET



NOTE: SEE 5/A2.2 FOR TYP. WINDOW HEAD DETAIL

EXT INT

MAINTAIN (E) WD SILL

MAINTAIN (E) WD SILL & TRIM

(E) GYPBD

TYP. WINDOW SILL DETAIL - ALLEY SIDE (8)

EXT INT

MAINTAIN (E) WD FRAME & TRIM

MAINTAIN (E) WD TRIM & MOULDING

MAINTAIN (E) WD WINDOW FRAME, TYP.

(N) WINDOW IN (E) FRAME, SEE SCHEDULE

MAINTAIN (E) WD SILL

MAINTAIN (E) WD SILL & TRIM

MAINTAIN (E) SHAPED SILL AT WALL

(E) GYPBD

TYP. WINDOW HEAD / SILL DETAIL - STREET SIDE (5)

MAINTAIN (E) WOOD TRIM AT JAMB & HEAD

RECESSED WINDOW

OGEE LUGS, TYP.

MAINTAIN (E) PROTRUDING WOOD WINDOW SILL

TYP. RECESSED WINDOW ELEVATION - ALLEY (7)

ALLEY ELEVATIONS

MAINTAIN (E) WOOD TRIM AT JAMB & HEAD

RECESSED WINDOW

OGEE LUGS, TYP.

MAINTAIN (E) WOOD WINDOW SILL

MAINTAIN (E) SHAPED SILL AT WALL

TYP. RECESSED WINDOW ELEVATION - STREET SIDE (4)

SHATTUCK, BANCROFT & DURANT ELEVATIONS

DESERT SHADOW KM49 I I KELLY-MOORE PAINT

GATE PAINT COLOR (1)

WINDOW TYPES: V.I.F. ALL WINDOW SIZES

NOTE: WINDOWS TO MATCH (E) WINDOW COLORS

OGEE LUGS, EACH SIDE

MARVIN CLAD ULTIMATE DOUBLE HUNG INSERT

WINDOW NOTES:

1. VERIFY IN FIELD ALL SIZES W/ OPENINGS. VERIFY ALL WINDOW QUANTITIES.
2. WINDOW GLASS LEGEND:  
T = TEMPERED  
O = OBSCURED
3. MANUFACTURED FENESTRATION PRODUCTS TO HAVE LABEL W/ CERTIFIED U-VALUE.
4. WINDOWS TO BE WEATHERSTRIPPED.
5. ALL JOINTS AND PENETRATIONS TO BE CAULKED AND SEALED.
6. WINDOWS TO BE DOUBLE GLAZED.

WINDOW SCHEDULE: V.I.F. ALL WINDOW SIZES

| WINDOW MARK | SIZE             | WALL FRAMING THICKNESS | GLASS (SEE WIN. NOTE 2) | CONSTRUCTION | RATING | FRAME | TRIM & FINISH | NOTES  | LOCATION |
|-------------|------------------|------------------------|-------------------------|--------------|--------|-------|---------------|--------|----------|
| 1           | ±3'-6" X ±5'-3"  | ± 1 0"                 | -                       | CLAD         | -      | WD    | PAINT         | V.I.F. | -        |
| 2           | ±2'-6" X ±4'-10" | ± 1 0"                 | -                       | CLAD         | -      | WD    | PAINT         | V.I.F. | -        |
| 3           | ±4'-9" X ±6'-10" | ± 1 0"                 | -                       | CLAD         | -      | WD    | PAINT         | V.I.F. | -        |
| 4           | ±3'-0" X ±5'-3"  | ± 1 0"                 | -                       | CLAD         | -      | WD    | PAINT         | V.I.F. | -        |
| 5           | ±3'-0" X ±3'-4"  | ± 1 0"                 | -                       | CLAD         | -      | WD    | PAINT         | V.I.F. | -        |

OWNER/CLIENT:  
2322 SHATTUCK LLC  
2278 SHATTUCK AVENUE  
BERKELEY, CA 94704  
(510)549-1954  
CONTACT: LAKSH LAKIREDDY

ARCHITECT OF RECORD:  
JAMES NOVOSEL

the bay architects

1840b alcatraz ave  
berkeley, ca 94703  
510.420.1484  
fax 510.420.1165  
www.bayarch.com  
bayarch@pacbell.net

APN: 055 189401704

PRINT DATE / PURPOSE  
2/12/18 LPC STRUCT. ALT. PERMIT

WINDOW DETAILS

A2.2

DRAWING SHEET





Office of the City Manager

INFORMATION CALENDAR

April 23, 2019

To: Honorable Mayor and Members of the City Council

From: Dee Williams-Ridley, City Manager

Submitted by: Timothy Burroughs, Director, Planning and Development

Subject: LPO NOD: 1414 Walnut Street/#LMSAP2018-0005 for the Former Garfield School

INTRODUCTION

The attached Landmarks Preservation Commission Notice of Decision (NOD) is presented to the Mayor and City Council pursuant to Berkeley Municipal Code/Landmarks Preservation Ordinance (BMC/LPO) Section 3.24.240.A, which requires that “a copy of the Notice of Decision shall be filed with the City Clerk, and the City Clerk shall present said copy to the City Council at its next regular meeting.”

CURRENT SITUATION AND ITS EFFECTS

The Landmark Preservation Commission (LPC/Commission) has approved a Structural Alteration Permit (SAP) for the subject City Landmark property. This action is subject to a 15-day appeal period, which began on April 8, 2019.

BACKGROUND

BMC/LPO Section 3.24.300 allows City Council to review any action of the Landmarks Preservation Commission in granting or denying a Structural Alteration Permit. In order for Council to review the decision on its merits, Council must appeal the Notice of Decision. To do so, a Council member must move this Information Item to Action and then move to set the matter for hearing on its own. Such action must be taken within 15 days of the mailing of the Notice of Decision, or by April 23, 2019. Such certification to Council shall stay all proceedings in the same manner as the filing of an appeal.

If the Council chooses to appeal the action of the Commission, then a public hearing will be set. The Council must rule on the application within 30 days of closing the hearing, otherwise the decision of the Commission is automatically deemed affirmed.

Unless the Council wishes to review the determination of the Commission and make its own decision, the attached NOD is deemed received and filed.

ENVIRONMENTAL SUSTAINABILITY

Landmark designation provides opportunities for the adaptive re-use and rehabilitation of historic resources within the City. The rehabilitation of these resources, rather than their removal, achieves construction and demolition waste diversion, and promotes investment in existing urban centers.

POSSIBLE FUTURE ACTION

The Council may choose to appeal the decision, in which case it would conduct a public hearing at a future date.

FISCAL IMPACTS OF POSSIBLE FUTURE ACTION

There are no known fiscal impacts associated with this action.

CONTACT PERSON

Timothy Burroughs, Director, Planning and Development Department, 510-981-7401  
Fatema Crane, Secretary to the Landmarks Preservation Commission, 510-981-7413  
Alison Lenci, Assistant Planner, 510-981-7544

Attachments:

1: Notice of Decision – #LMSAP2018-0005 for 1414 Walnut Street



L A N D M A R K S  
P R E S E R V A T I O N  
C O M M I S S I O N

---

N O T I C E O F D E C I S I O N

**DATE OF BOARD DECISION: February 7, 2019**  
**DATE NOTICE MAILED: April 8, 2019**  
**APPEAL PERIOD EXPIRATION: April 23, 2019**  
**EFFECTIVE DATE OF PERMIT (Barring Appeal or Certification): April 24, 2019<sup>1</sup>**

## 1414 Walnut Street

**Structural Alteration Permit LMSAP2018-0005 to replace existing fences at a City Landmark property, the Former Garfield School, currently used as a community center.**

The Landmarks Preservation Commission of the City of Berkeley, after conducting a public hearing, **APPROVED** the following permit:

**PERMITS REQUIRED:**

- Structural Alteration permit

**APPLICANT:** David Trachtenberg, Trachtenberg Architects, Inc.  
2421 Fourth Street, Berkeley, CA 94710

**PROPERTY OWNER:** Jewish Community Center East Bay  
1414 Walnut Street, Berkeley, CA 94709

**ZONING DISTRICT:** R-2A – Restricted Multiple-Family Residential

**ENVIRONMENTAL REVIEW STATUS:** Categorically exempt from environmental review pursuant to Section 15331 of the CEQA Guidelines for Historical Resource Rehabilitation.

**The Application materials for this project are available online at:**  
<http://www.cityofberkeley.info/zoningapplications>

---

<sup>1</sup> Pursuant to BMC Section 1.04.070, if the close of the appeal period falls on a weekend or holiday, then the appeal period expires the following business day. Pursuant to BMC Section 3.24.190, the City Council may “certify” any decision of the LPC for review, within fifteen days from the mailing of the NOD. Such certification shall stay all proceedings in the same manner as the filing of a notice of appeal.

LANDMARKS PRESERVATION COMMISSION  
NOTICE OF DECISION  
LMSAP2018-0005  
1414 Walnut Street  
April 8, 2019  
Page 2 of 5

---

**FINDINGS, CONDITIONS AND APPROVED PLANS ARE ATTACHED TO THIS NOTICE**

---

**COMMISSION VOTE: 7-0-0-2**

**YES:** ABRANCHES DA SILVA, ADAMS, BEIL, CRANDALL, FINACOM, O'MALLEY, SCHWARTZ

**NO:** NONE

**ABSTAIN:** NONE

**ABSENT:** ALLEN, BROWN

**TO APPEAL THIS DECISION (see Section 3.24.300 of the Berkeley Municipal Code):**

To appeal a decision of the Landmarks Preservation Commission to the City Council you must:

1. Submit a letter clearly and concisely setting forth the grounds for the appeal to the City Clerk, located at 2180 Milvia Street, 1<sup>st</sup> Floor, Berkeley; or by facsimile to (510) 981-6901. The City Clerk's telephone number is (510) 981-6900.
2. The appeal must be received prior to 5:00 p.m. on the "APPEAL PERIOD EXPIRATION" date shown above (if the close of the appeal period falls on a weekend or holiday, then the appeal period expires the following business day).
3. Submit the required fee (checks and money orders must be payable to 'City of Berkeley'):
  - a. The basic fee for persons other than the applicant is \$500. This fee may be reduced to \$100 if the appeal is signed by persons who lease or own at least 50 percent of the parcels or dwelling units within 300 feet of the project site, or at least 25 such persons (not including dependent children), whichever is less.
  - b. The fee for appeals of affordable housing projects (defined as projects which provide 50 percent or more affordable units for households earning 80% or less of Area Median Income) is \$500, which may not be reduced.
  - c. The fee for all appeals by Applicants is \$2500.

LANDMARKS PRESERVATION COMMISSION  
NOTICE OF DECISION  
LMSAP2018-0005  
1414 Walnut Street  
April 8, 2019  
Page 3 of 5

**STRUCTURAL ALTERATION PERMIT ISSUANCE:**

If no appeal is received, the Structural Alteration permit will be issued on the first business day following expiration of the appeal period, and the project may proceed at that time. Information about the Building Permit process can be found at the following link:

<http://www.ci.berkeley.ca.us/permitservicecenter/>.

**NOTICE CONCERNING YOUR LEGAL RIGHTS:**

---

If you object to this decision, the following requirements and restrictions apply:

1. If you challenge this decision in court, you may be limited to raising only those issues you or someone else raised at the public hearing described in this notice, or in written correspondence delivered to the Landmarks Preservation Commission at, or prior to, the public hearing.
2. You must appeal to the City Council within fifteen (15) days after the Notice of Decision of the action of the Landmarks Preservation Commission is mailed. It is your obligation to notify the Land Use Planning Division in writing of your desire to receive a Notice of Decision when it is completed.
3. Pursuant to Code of Civil Procedure Section 1094.6(b) and Government Code Section 65009(c)(1), no lawsuit challenging a City Council decision, as defined by Code of Civil Procedure Section 1094.6(e), regarding a use permit, variance or other permit may be filed more than ninety (90) days after the date the decision becomes final, as defined in Code of Civil Procedure Section 1094.6(b). Any lawsuit not filed within that ninety (90) day period will be barred.
4. Pursuant to Government Code Section 66020(d)(1), notice is hereby given to the applicant that the 90-day protest period for any fees, dedications, reservations, or other exactions included in any permit approval begins upon final action by the City, and that any challenge must be filed within this 90-day period.
5. If you believe that this decision or any condition attached to it denies you any reasonable economic use of the subject property, was not sufficiently related to a legitimate public purpose, was not sufficiently proportional to any impact of the project, or for any other reason constitutes a "taking" of property for public use without just compensation under the California or United States Constitutions, your appeal of this decision must including the following information:
  - A. That this belief is a basis of your appeal.
  - B. Why you believe that the decision or condition constitutes a "taking" of property as set forth above.
  - C. All evidence and argument in support of your belief that the decision or condition constitutes a "taking" as set forth above.

If you do not do so, you will waive any legal right to claim that your property has been

LANDMARKS PRESERVATION COMMISSION  
NOTICE OF DECISION  
LMSAP2018-0005  
1414 Walnut Street  
April 8, 2019  
Page 4 of 5

taken, both before the City Council and in court.

**PUBLIC COMMENT:**

---

Communications to Berkeley boards, commissions or committees are public record and will become part of the City's electronic records, which are accessible through the City's website. **Please note: e-mail addresses, names, addresses, and other contact information are not required, but if included in any communication to a City board, commission or committee, will become part of the public record.** If you do not want your e-mail address or any other contact information to be made public, you may deliver communications via U.S. Postal Service or in person to the secretary of the relevant board, commission or committee. If you do not want your contact information included in the public record, please do not include that information in your communication. Please contact the secretary to the relevant board, commission or committee for further information.

**FURTHER INFORMATION:**

---

Questions about the project should be directed to the project planner, Alison Lenci, at (510) 981-7410 or [alenci@cityofberkeley.info](mailto:alenci@cityofberkeley.info). All project application materials, including full-size plans, may be viewed at the Permit Service Center (Zoning counter), 2120 Milvia Street, between 8 a.m. and 4 p.m., Monday through Friday.

**ATTACHMENTS:**

---

1. Findings and Conditions
2. Project Plans, received JANUARY 10, 2019

ATTEST: 

Fatema Crane, Secretary  
Landmarks Preservation Commission

cc: Applicant  
Owner  
City Clerk



LANDMARKS PRESERVATION COMMISSION  
NOTICE OF DECISION  
LMSAP2018-0005  
1414 Walnut Street  
April 8, 2019  
Page 5 of 5

Applicant: David Trachtenberg, Trachtenberg Architects, Inc.  
2421 Fourth Street  
Berkeley, CA 94710

Property Owner: Jewish Community Center East Bay  
1414 Walnut Street  
Berkeley, CA 94710

# ATTACHMENT 1

## FINDINGS AND CONDITIONS

### 1414 Walnut Street - The Former Garfield School

#### Structural Alteration Permit #LMSAP2018-0005

To make replace existing fences at a City Landmark property, the Former Garfield School, currently used as a community center.

#### FINDINGS REQUIRED UNDER THE CALIFORNIA ENVIRONMENTAL QUALITY ACT

1. The project is categorically exempt from the provisions of the California Environmental Quality Act (CEQA, Public Resources Code §21000, et seq. and California Code of Regulations, §15000, et seq.) pursuant to Section 15331 of the CEQA Guidelines (“Historic Resource Restoration/Rehabilitation”). Furthermore, none of the exceptions in CEQA Guidelines Section 15300.2 apply, as follows: (a) the site is not located in an environmentally sensitive area, (b) there are no cumulative impacts, (c) there are no significant effects, (d) the project is not located near a scenic highway, (e) the project site is not located on a hazardous waste site pursuant to Government Code Section 65962.5, and (f) the project will not affect any historical resource.

#### FINDINGS RELATED TO THE SECRETARY OF THE INTERIOR’S STANDARDS

Regarding the Secretary of the Interior’s Standards for Rehabilitation, the Landmarks Preservation Commission of the City of Berkeley makes the following findings:

1. This property will retain its original use as a community and institutional use with this proposed project.
2. The new fencing is proposed to wrap around the play yard area on the site, south of the Garfield school, and would not alter any features, spaces, or spatial relationships that characterize the property.
3. There are no proposed alterations to the building and, therefore, the project would not create a false sense of historical development at this City Landmark property.
4. While the building has undergone some alterations since its construction, there are no proposed alterations to the building in this project proposal and, therefore, the proposal would not affect any changes which have acquired significance.
5. The distinctive features of the historic, Mission Revival, outdoor school style of the Garfield School building, and the existing materials that are associated with its original construction, would be preserved with this alteration request.
6. This proposal does not include removal of deteriorated building features which are historic.

7. Chemical or physical treatments, if appropriate, will be undertaken using the gentlest means possible. Treatments that cause damage to historic materials are prohibited by the Conditions herein.
8. Any archeological resources at this site will be unaffected by the proposed work which includes no excavation.
9. Exterior alterations, or related new construction will not destroy historic features, significant amounts of historic materials, or the spatial relationships that characterize the property. The new work will be differentiated from the old, and with the implementation of Conditions of Approval 7-8, will be compatible with the historic materials, features, size, scale and proportion, and massing to protect the integrity of the property and its environment.
10. The proposed new construction will be undertaken in such a manner that, if removed in the future, the essential form and integrity of the historic property and its environment would be unimpaired.

#### **FINDINGS REQUIRED UNDER LANDMARK PRESERVATION ORDINANCE**

---

1. As required by Section 3.24.260 of the Landmarks Preservation Ordinance, the Commission finds that proposed work is appropriate for and consistent with the purposes of the Ordinance, and will preserve and enhance the characteristics and features specified in the designation for this property. Specifically:
  - The new fence would not adversely affect its Mission Revival architectural features and outdoor school design because the new work would be along the exterior playground area and would retain the building's overall massing, scale, and form, and therefore would not adversely affect the character defining features of this building.
  - The proposed fencing would retain the architectural and historical value of the subject Landmark building and improve security for its existing tenant, the JCC. In these ways, the project ensures that the building and property would remain an attractive and unique element of this residential and commercial neighborhood area.

## STANDARD CONDITIONS

---

The following conditions, as well as all other applicable provisions of the Landmarks Preservation Ordinance, apply to this Permit:

### 1. Conditions Shall be Printed on Plans

The conditions of this Permit shall be printed on the *second* sheet of each plan set submitted for a building permit pursuant to this Permit, under the title 'Structural Alteration Permit Conditions'. *Additional sheets* may also be used if the *second* sheet is not of sufficient size to list all of the conditions. The sheet(s) containing the conditions shall be of the same size as those sheets containing the construction drawings; 8-1/2" by 11" sheets are not acceptable.

### 2. Plans and Representations Become Conditions

Except as specified herein, the site plan, floor plans, building elevations and/or any additional information or representations, whether oral or written, indicating the proposed structure or manner of operation submitted with an application or during the approval process are deemed conditions of approval.

### 3. Subject to All Applicable Laws and Regulations

The approved use and/or construction is subject to, and shall comply with, all applicable City Ordinances and laws and regulations of other governmental agencies. Prior to construction, the applicant shall identify and secure all applicable permits from the Zoning Adjustments Board or Zoning Officer, Building and Safety Division, Public Works Department and other affected City divisions and departments.

### 4. Exercise and Lapse of Permits (Section 23B.56.100)

- B. A permit for the construction of a building or structure is deemed exercised when a valid City building permit, if required, is issued, and construction has lawfully commenced.
- A. A permit may be declared lapsed and of no further force and effect if it is not exercised within one year of its issuance, except that permits for construction or alteration of structures or buildings may not be declared lapsed if the permittee has:
  - (1) applied for a building permit; or, (2) made substantial good faith efforts to obtain a building permit and begin construction, even if a building permit has not been issued and/or construction has not begun.

### 5. Indemnification Agreement

The applicant shall hold the City of Berkeley and its officers harmless in the event of any legal action related to the granting of this Permit, shall cooperate with the City in defense of such action, and shall indemnify the City for any award of damages or attorneys fees that may result.

**ADDITIONAL CONDITIONS**

---

The following additional conditions are attached to this Permit:

- 6. Chemical Treatments.** Any chemical treatments needed as construction progresses will be undertaken using the gentlest means possible.

**Prior to any Building Permit submittal:**

- 7.** Prior to submitting any building permit for this project, the applicant shall revise the project plans to include a vertical vine pattern on the proposed new fence. Vine plantings shall be aligned with at least every other fence post, to accentuate the rhythm of the poles with the vines.

**At all times:**

- 8.** Irrigated, water efficient landscape. The property owner shall maintain automatic irrigation and drainage facilities adequate to assure healthy growing conditions for all required planting and landscape. The landscape shall be drought-tolerant and achieve maximum water efficiency.

### GENERAL NOTES

- THE CONTRACTOR SHALL EXECUTE THE WORK OF THIS PROJECT IN FULL COMPLIANCE WITH THE FOLLOWING CODE EDITIONS: 2016 CBC, 2016 CMC, 2016 CPC, 2016 CFC, 2016 CEC, 2016 TITL 24 ENERGY STANDARDS AND THE 2016 CAL GREEN BUILDING STANDARDS CODE. AS AMENDED BY THE CITY OF BERKELEY. THE CONTRACTOR SHALL GIVE ALL NOTICES AND COMPLY WITH ALL APPLICABLE REGULATIONS, LAWS, ORDINANCES AND ORDERS BY ANY PUBLIC AUTHORITY HAVING JURISDICTION OVER THE PROJECT. THE CONTRACTOR SHALL BRING TO THE ATTENTION OF THE ARCHITECT IN A TIMELY FASHION ANY DISCREPANCIES OR CONFLICTS BETWEEN THE REQUIREMENTS OF APPLICABLE CODES AND THE DRAWINGS OF WHICH THE CONTRACTOR IS OR BECOMES AWARE.
- THE CONTRACTOR SHALL STUDY THE CONTRACT DOCUMENTS AND REPORT TO THE ARCHITECT IN WRITING ALL INCONSISTENCIES AND OMISSIONS HE FINDS PRIOR TO COMMENCING WORK. THE CONTRACTOR SHALL BECOME FAMILIAR WITH THE EXISTING CONDITIONS OF THE SITE AND PROJECT PRIOR TO COMMENCING WORK. IF THE CONTRACTOR PROCEEDS WITH ANY OF THE WORK WITHOUT INSTRUCTIONS OF THE ARCHITECT, WHERE SUCH INSTRUCTIONS ARE REQUIRED BY THE CONTRACT DOCUMENTS, THE CONTRACTOR SHALL MAKE GOOD AT HIS OWN COST ANY RESULTING ERROR, DAMAGE, OR DEFECTS.
- WRITTEN DIMENSIONS ON DRAWINGS SHALL TAKE PRECEDENCE OVER DIMENSIONS SCALED FROM DRAWINGS. CONTRACTOR SHALL NOT SCALE DRAWINGS. IF A DIMENSION(S) HAS BEEN OMITTED THE CONTRACTOR SHALL BRING THIS TO THE ATTENTION OF THE ARCHITECT IN A TIMELY FASHION.
- CONTRACTOR SHALL VERIFY DIMENSIONS AND DETAILS OF ALL PROJECT COMPONENTS. CONTRACTOR SHALL BE RESPONSIBLE FOR INSTALLATION CLEARANCES OF ALL ITEMS, INCLUDING BUT NOT LIMITED TO MECHANICAL AND ELECTRICAL EQUIPMENT, AND CABINET WORK, TO BE INSTALLED IN THE PROJECT.
- THE CONTRACTOR SHALL BE RESPONSIBLE FOR INITIATING, MAINTAINING AND SUPERVISING ALL SAFETY PRECAUTION PROGRAMS IN CONNECTION WITH WORK, AND FOR MAINTAINING APPROPRIATE INSURANCE TO PROTECT THE CONTRACTOR, THE OWNER AND THE ARCHITECT.
- CONTRACTOR SHALL PROTECT THE ADJACENT PROPERTY, THE PUBLIC AND SHALL BE RESPONSIBLE FOR ANY DAMAGE OR INJURY DUE TO HIS NEGLIGENCE.
- THE ARCHITECT WILL ASSIST THE OWNER IN SUBMITTING PLANS TO THE DEPARTMENT OF BUILDINGS FOR BUILDING PERMIT APPLICATION. ARCHITECT WILL ANSWER BUILDING DEPARTMENTS' PLAN CHECK COMMENTS AND RE SUBMIT AS REQUIRED. THE OWNER WILL SECURE AND PAY FOR THE BUILDING PERMIT. CONTRACTOR WILL PAY FOR ALL OTHER PERMITS (INCLUDING ANY REQUIRED SIDEWALK SHED PERMITS, PARKING OR DUMPSTER PERMITS), LICENSES, INSPECTIONS AND THE LIKE REQUIRED TO EFFECT THE WORK OF THE CONTRACT DOCUMENTS THROUGH RECEIPT OF A CERTIFICATE OF OCCUPANCY.
- CONTRACTOR SHALL CONSULT WITH REPRESENTATIVES OF APPLICABLE UTILITIES, INCLUDING BUT NOT LIMITED TO GAS, WATER, POWER, SEWER, TELEPHONE, AND CABLE TELEVISION, DETERMINE EXACT LOCATIONS AND AVAILABILITY OF UTILITIES, AND DETERMINE CONDITION OF EXISTING SERVICES PRIOR TO COMMENCING WORK. CONTRACTOR SHALL ADVISE ARCHITECT AND OWNER OF UNANTICIPATED CHANGES TO THE EXISTING SERVICES REQUIRED FOR THE SUCCESSFUL COMPLETION AND OPERATION OF THE PROJECT SHALL BE BROUGHT TO THE ATTENTION OF THE ARCHITECT AND OWNER PRIOR TO COMMENCEMENT OF CONSTRUCTION.
- CONTRACTOR SHALL ERECT AND MAINTAIN TEMPORARY BARRICADES AND DUST-PROOF PARTITIONS AS NEEDED FOR PROTECTION AGAINST NUISANCE AND ACCIDENT, AND SHALL CONTINUOUSLY MAINTAIN ADEQUATE PROTECTION OF HIS WORK AND THE OWNERS PROPERTY FROM DAMAGE OR LOSS ARISING IN CONNECTION WITH THE WORK OF THIS PROJECT.
- IMPROVEMENTS ON THE SITE, WORK IN PROGRESS, STORED MATERIALS ON PROPERTY SHALL BE PROTECTED BY THE CONTRACTOR FROM DAMAGE ARISING FROM THE WORK AND FROM NORMAL USE OF THE SITE DURING THE COURSE OF THE WORK, WHETHER BY THE CONTRACTOR OR ANY OTHER PARTY. ALL ITEMS DAMAGED DUE TO INSUFFICIENT PROTECTION SHALL BE FULLY RESTORED TO THEIR PRIOR CONDITION BY THE CONTRACTOR AT NO COST TO THE OWNER.
- PARTITION DIMENSIONS ARE TO FACE OF STUD UNLESS NOTED OTHERWISE. OTHER COMPONENTS ARE DIMENSIONED TO DIMENSION POINTS SHOWN ON DETAILS, OR AS NOTED ON THE DRAWINGS.
- NO PART OF THE STRUCTURE SHALL BE OVERLOADED BEYOND ITS SAFE CARRYING CAPACITY BY THE PLACING OF MATERIALS, EQUIPMENT, TOOLS, MACHINERY OR ANY OTHER ITEMS DURING THE COURSE OF THE CONTRACTORS WORK.
- AT THE COMPLETION OF THE WORK, THE CONTRACTOR SHALL CLEAN HIS AND THE SURROUNDING AREA, REMOVE ALL WASTE MATERIALS AND RUBBISH FROM THE PROJECT AS WELL AS HIS OR HER TOOLS, CONSTRUCTION EQUIPMENT, MACHINERY AND SURPLUS MATERIALS. THE CONTRACTOR SHALL REMOVE PUTTY AND PAINT FROM ALL GLASS, MIRRORS, AND WASH AND POLISH SAME; REMOVE ALL LABELS, TAGS, GREASE, DIRT, STAINS, ETC. AND CLEAN ALL FIXTURES AND EQUIPMENT TO THE EXTENT OF RESTORING THEM TO THE ORIGINAL FINISH.
- THE CONTRACTOR SHALL MAINTAIN A CURRENT COPY OF THE 2013 CBC ON SITE.
- CONTRACTOR SHALL BE RESPONSIBLE FOR SECURITY OF THE SITE, CONSTRUCTION-IN-PROGRESS, AND STORED MATERIALS AND EQUIPMENT, WHETHER ON- OR OFF-SITE.
- THE OWNER SHALL PAY FOR TESTING OF ANY MATERIALS DISCOVERED ON THE SITE BY THE ARCHITECT, OWNER OR CONTRACTOR SUSPECTED OF CONTAINING TOXIC SUBSTANCES REQUIRING SPECIAL REMOVAL AND DISPOSAL. CHANGES TO THE CONTRACT RESULTING FROM THE DISCOVERY, TESTING, OR REMOVAL OF SUCH MATERIALS (IF ANY) SHALL BE EFFECTED BY A CHANGE ORDER.
- GENERAL CONTRACTOR WILL BE RESPONSIBLE FOR ANY AND ALL WORK PROVIDED BY ANY AND ALL SUBCONTRACTORS. GENERAL NOTES THAT REFER TO 'CONTRACTOR' INCLUDE ALL WORK PROVIDED BY SUBCONTRACTORS. CONTRACTOR AND ALL SUBCONTRACTORS SHALL VERIFY ALL GRADES, DIMENSIONS, AND CONDITIONS IN FIELD PRIOR TO THE START OF PROJECT AND AT APPROPRIATE TIMES DURING THE COURSE OF CONSTRUCTION BEFORE RELATED PROJECT PHASES.
- EACH SUBCONTRACTOR IS CONSIDERED A SPECIALIST IN HIS RESPECTIVE FIELD AND SHALL, PRIOR TO THE SUBMISSION OF HIS BID AND THE PERFORMANCE OF WORK, NOTIFY THE CONTRACTOR OF ANY WORK CALLED OUT IN THE CONSTRUCTION DOCUMENTS WHICH CANNOT BE EXECUTED AS INDICATED OR CANNOT BE FULLY GUARANTEED. THE CONTRACTOR WILL THEN NOTIFY THE OWNER AND ARCHITECT PRIOR TO ACCEPTANCE OF SUBCONTRACTORS BID.
- THE ARCHITECT HAS MADE THE ASSUMPTION THAT EXISTING CONCEALED CONDITIONS ARE STANDARD. THE CONTRACTOR WILL BE EXPECTED TO PERFORM THE NECESSARY WORK TO COMPLETE THE INDICATED CONSTRUCTION. IN THE EVENT THAT DEMOLITION REVEALS UNEXPECTED CONDITIONS, THE CONTRACTOR MUST INFORM THE OWNER AND ARCHITECT OF ANTICIPATED CHANGE ORDERS IN ADVANCE.
- CONTRACTOR IS TO PROVIDE SAMPLES OF REQUESTED SUBMITTALS AND OF ALL PROPOSED MATERIAL SUBSTITUTIONS TO THE ARCHITECT FOR REVIEW. THE ARCHITECT WILL REQUIRE FIVE WORKING DAYS FOR REVIEW OF ALL SUBMITTALS INCLUDING SHOP DRAWINGS. SHOP DRAWINGS AND MATERIALS TO THE ARCHITECT WILL HAVE BEEN REVIEWED AND APPROVED BY THE CONTRACTOR. BY SUBMITTING SHOP DRAWINGS AND SUBMITTALS TO THE ARCHITECT, THE CONTRACTOR REPRESENTS THAT THE CONTRACTOR HAS DETERMINED AND PERIODIC MATERIAL, FIELD MEASUREMENTS, AND FIELD CONSTRUCTION RELATED THERETO, AND HAS CHECKED AND COORDINATED THE INFORMATION CONTAINED WITHIN SUCH SUBMITTALS WITH THE REQUIREMENTS OF THE WORK AND OF THE CONTRACT DOCUMENTS. THE ARCHITECT'S REVIEW OF SUBMITTALS AND SHOP DRAWINGS IS FOR CONFIRMATION OF DESIGN INTENT ONLY.
- THESE CONTRACT DOCUMENTS INTEND TO DESCRIBE A FINISHED PROJECT READY FOR LEGAL USE.
- ANY CHANGE, MODIFICATION OR INTERPRETATION OF THE SCOPE OR REQUIREMENTS OF THESE DOCUMENTS UNDERTAKEN WITHOUT CONSULTATION WITH THE ARCHITECT (AND ANY UNFORESEEN CONDITIONS RESULTING THEREFROM) SHALL BE THE RESPONSIBILITY OF THE OWNER OR CONTRACTOR AS THE CASE MAY BE. AS STIPULATED IN THE OWNER/ARCHITECT AGREEMENT, TRACHTENBERG ARCHITECTS SHALL BE HELD HARMLESS FROM ANY CLAIMS RESULTING FROM SUCH ACTIVITY

### ABBREVIATIONS

|    |                 |          |                                       |
|----|-----------------|----------|---------------------------------------|
| &  | AND             | JT.      | JOINT                                 |
| @  | ANGLE           | AM.      | LAMINATE                              |
| CL | CENTER LINE     | LT.      | LIGHT                                 |
| #  | FOUND OR NUMBER | M.B.     | MACHINE BOLT                          |
| d  | PENNY           | MAX.     | MAXIMUM                               |
|    |                 | MECH.    | MECHANICAL                            |
|    |                 | MEMB.    | MEMBRANE                              |
|    |                 | MET_MTL. | METAL                                 |
|    |                 | MFR.     | MANUFACTURER                          |
|    |                 | MIN.     | MINIMUM                               |
|    |                 | MISC.    | MISCELLANEOUS                         |
|    |                 | M.O.     | MASONRY OPENING                       |
|    |                 | MTD.     | MOUNTED                               |
|    |                 | MUL.     | MULLION                               |
|    |                 | (N)      | NEW                                   |
|    |                 | (N)      | NORTH                                 |
|    |                 | N.I.C.   | NOT IN CONTRACT                       |
|    |                 | NO.      | NUMBER                                |
|    |                 | N.T.S.   | NOT TO SCALE                          |
|    |                 | O.       | OVER                                  |
|    |                 | O.C.     | ON CENTER                             |
|    |                 | O.F.C.I. | OWNER FURNISHED, CONTRACTOR INSTALLED |
|    |                 | P. LAM.  | PLASTIC LAMINATE                      |
|    |                 | PLYWD.   | PLYWOOD                               |
|    |                 | P.T.     | PRESSURE-TREATED                      |
|    |                 | PTD.     | PAINTED                               |
|    |                 | PTN.     | PARTITION                             |
|    |                 | Q.T.     | QUARRY TILE                           |
|    |                 | R.       | RISER                                 |
|    |                 | RAD.     | RADIUS                                |
|    |                 | REF.     | REFRIGERATOR                          |
|    |                 | RENF.    | REINFORCED                            |
|    |                 | REQ.     | REQUIRED                              |
|    |                 | RESIL.   | RESILIENT                             |
|    |                 | RM.      | ROOM                                  |
|    |                 | R.O.     | ROUGH OPENING                         |
|    |                 | RWD.     | REDWOOD                               |
|    |                 | RWL.     | RAINWATER LEADER                      |
|    |                 | SQ. FT.  | SQUARE FEET                           |
|    |                 | SHT.     | SHEET                                 |
|    |                 | SQ. IN.  | SQUARE INCH                           |
|    |                 | SM.      | SIMILAR                               |
|    |                 | S.L.D.   | SEE LANDSCAPE DRAWING                 |
|    |                 | S.M.D.   | SEE MECHANICAL DRAWING                |
|    |                 | SPEC.    | SPECIFICATIONS                        |
|    |                 | SQ.      | SQUARE                                |
|    |                 | S.S.     | STAINLESS STEEL                       |
|    |                 | STD.     | STANDARD                              |
|    |                 | STL.     | STEEL                                 |
|    |                 | STOR.    | STORAGE                               |
|    |                 | S.S.D.   | SEE STRUCTURAL DRAWING                |
|    |                 | TEL.     | TELEPHONE                             |
|    |                 | T&G      | TONGUE AND GROOVE                     |
|    |                 | T.O.P.   | TOP OF                                |
|    |                 | T.O.S.   | TOP OF SLAB                           |
|    |                 | T.O.T.   | TOP OF TRUSS                          |
|    |                 | U.O.N.   | UNLESS OTHERWISE NOTED                |
|    |                 | VERT.    | VERTICAL                              |
|    |                 | V.I.F.   | VERIFY IN FIELD                       |
|    |                 | V.G.     | VERTICAL GRAN                         |
|    |                 | W        | WIDTH                                 |
|    |                 | WD       | WOOD                                  |
|    |                 | WDW      | WINDOW                                |
|    |                 | WO       | WITHOUT                               |
|    |                 | WP       | WATERPROOF                            |
|    |                 | WRC      | WESTERN RED CEDAR                     |

### SYMBOL LEGEND

|  |                                 |  |                                          |
|--|---------------------------------|--|------------------------------------------|
|  | ELEVATION/CONTROL POINT         |  | DETAIL NUMBER                            |
|  | REVISION NUMBER                 |  | SHEET NUMBER                             |
|  | REVISION                        |  | DETAIL NUMBER                            |
|  | WALL CONSTRUCTION TYPE          |  | ELEVATION/SECTION SHEET NUMBER           |
|  | WINDOW SEE WINDOW SCHEDULE      |  | INTERIOR ELEVATION SHEET NUMBER          |
|  | DOOR SEE DOOR SCHEDULE          |  | REFERENCE GRID COLUMN CENTER LINE U.O.N. |
|  | ROOM NUMBER SEE FINISH SCHEDULE |  | REFERENCE GRID EDGE OF FRAMING U.O.N.    |
|  |                                 |  | CHANGE IN ELEVATION                      |

### PROJECT DESCRIPTION

PROJECT ADDRESS: 1414 Walnut Street, Berkeley, CA 94709 (APN: 59-2261-1-1)

SCOPE OF WORK:  
VOLUNTARY FEMA/HOMELAND SECURITY UPGRADE WORK;  
REPLACEMENT OF SITE FENCE AROUND PLAY YARD WITH 8' HIGH FENCING.

ZONING CODE ANALYSIS  
(BASED ON THE BERKELEY ZONING ORDINANCE)

ZONING: R-2A

EXISTING USE: COMMUNITY CENTER (NO CHANGE)

| FLOOR AREA: | EXISTING  | PROPOSED | PERMITTED |
|-------------|-----------|----------|-----------|
| 21,352 SF   | NO CHANGE |          |           |

| LOT AREA: | EXISTING  | PROPOSED | PERMITTED |
|-----------|-----------|----------|-----------|
| 47,440 (  | NO CHANGE |          |           |

| LOT COVERAGE: | EXISTING  | PROPOSED | PERMITTED |
|---------------|-----------|----------|-----------|
| 45%           | NO CHANGE |          | 50%       |

| FAR: | EXISTING  | PROPOSED | PERMITTED |
|------|-----------|----------|-----------|
| .45  | NO CHANGE |          | N/A       |

| BUILDING HEIGHT: | EXISTING  | PROPOSED | PERMITTED |
|------------------|-----------|----------|-----------|
| +/- 20'          | NO CHANGE |          | 28'       |

| BUILDING STORIES: | EXISTING  | PROPOSED | PERMITTED |
|-------------------|-----------|----------|-----------|
| 1                 | NO CHANGE |          | 3         |

SETBACKS:

| FRONT: | EXISTING  | PROPOSED | PERMITTED |
|--------|-----------|----------|-----------|
| +/-15' | NO CHANGE |          | 15'       |

| STREET SIDE SIDE: | EXISTING  | PROPOSED | PERMITTED                   |
|-------------------|-----------|----------|-----------------------------|
| +/-5'             | NO CHANGE |          | 4' per (BMC230.32.070.D.3B) |

| SIDE YARD: | EXISTING  | PROPOSED | PERMITTED |
|------------|-----------|----------|-----------|
| +/-7'      | NO CHANGE |          | 4'        |

| REAR:      | EXISTING  | PROPOSED | PERMITTED |
|------------|-----------|----------|-----------|
| +/- 129' ( | NO CHANGE |          | 15'       |

PARKING: (NO CHANGE)

BUILDING CODE ANALYSIS  
(BASED ON THE 2016 CALIFORNIA BUILDING CODE)

OCCUPANCY: A-3 (COMMUNITY HALL) & E (DAY-CARE) - (NO CHANGE OF USE)

CONSTRUCTION TYPE: V-B (EXISTING - UNSPRINKLERED)

SPRINKLER SYSTEM: NO (NO CHANGE)

FIRE ALARM: UNKNOWN (NO CHANGE)

| # OF STORIES: | EXISTING  | PROPOSED | PERMITTED |
|---------------|-----------|----------|-----------|
| 1             | NO CHANGE |          |           |

| HEIGHT: | EXISTING  | PROPOSED | PERMITTED |
|---------|-----------|----------|-----------|
| =20'    | NO CHANGE |          |           |

| AREA:     | EXISTING  | PROPOSED | PERMITTED |
|-----------|-----------|----------|-----------|
| 21,502 SF | NO CHANGE |          |           |

### DRAWING LIST

| SHEET NO. & TITLE                      | SUBMISSION & DATE                |
|----------------------------------------|----------------------------------|
| A0.0 GENERAL INFORMATION               | 01/07/2019 LPC AND AUP SUBMITTAL |
| A1.1 EXISTING SITE PLAN                |                                  |
| A3.1 EXTERIOR ELEVATIONS WALNUT STREET |                                  |
| A3.2 EXTERIOR ELEVATIONS SOUTH         |                                  |
| L1.0 PLANTING PLAN                     |                                  |

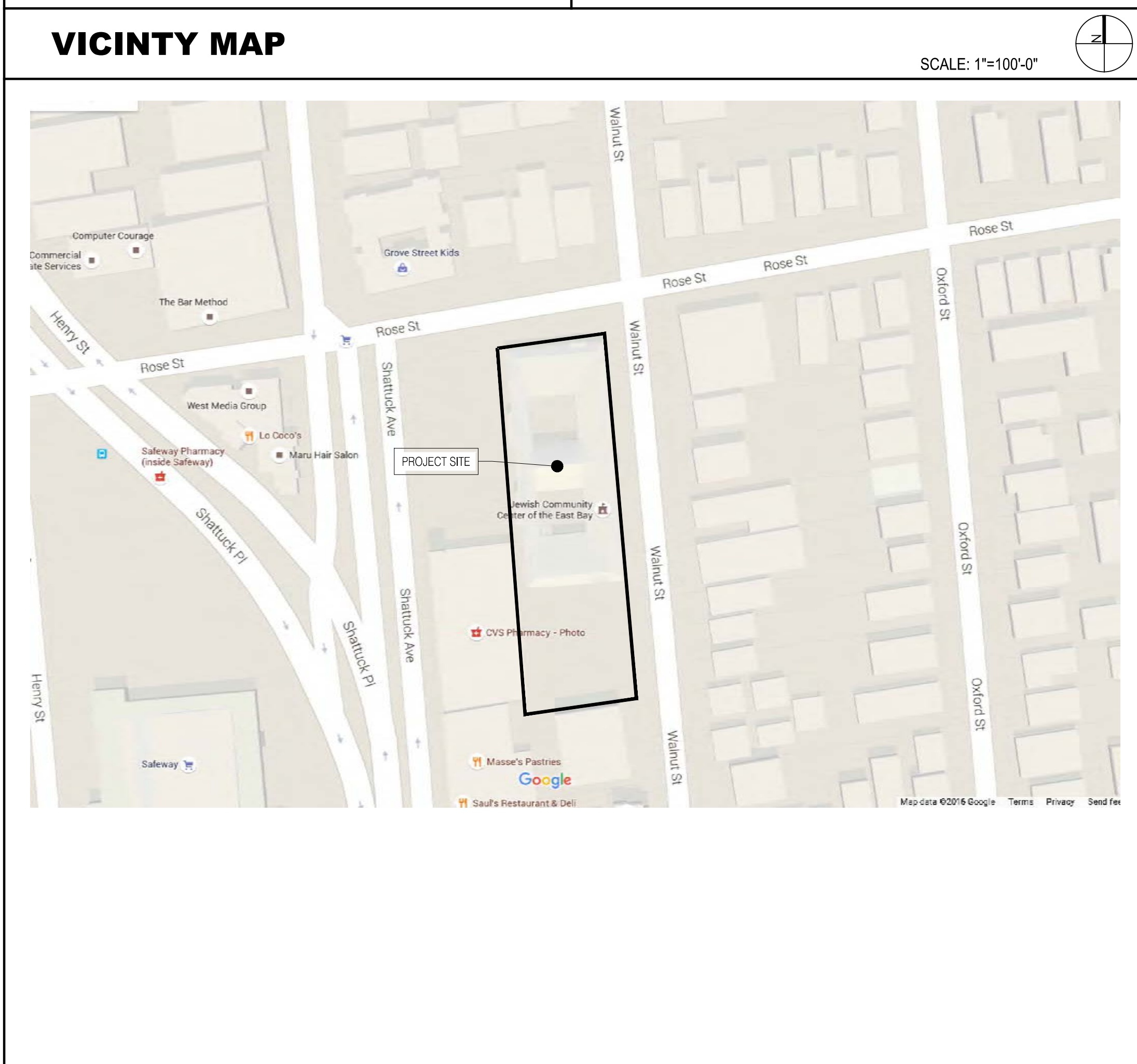

### PROJECT DIRECTORY

CLIENT:  
Jewish Community Center of the East Bay  
1414 Walnut Street  
Berkeley, CA 94709  
(510)846-0237

ARCHITECT:  
Trachtenberg Architects  
2421 Fourth Street  
Berkeley, CA 94710  
(510) 649-1414  
www.TrachtenbergArch.com

ALL DRAWINGS AND WRITTEN MATERIAL APPEARING HEREIN CONSTITUTE ORIGINAL AND UNPUBLISHED WORK OF THE ARCHITECT AND MAY NOT BE DUPLICATED, USED OR DISCLOSED WITHOUT WRITTEN CONSENT OF TRACHTENBERG ARCHITECTS.

JOB: - DRAWN BY:

SCALE: - DATE:

SHEET:

TRACHTENBERG ARCHITECTS

2421 Fourth Street  
Berkeley, California 94710  
510.649.1414  
www.TrachtenbergArch.com

BERKELEY JCC  
FEMA UPGRADES

1414 Walnut Street  
Berkeley, CA 94709

11.19.2018 LPC AND AUP SUBMITTAL

GENERAL INFORMATION

# A0.0

TRACHTENBERG  
ARCHITECTS

2421 Fourth Street  
Berkeley, California 94710  
510.649.1414  
www.TrachtenbergArch.com



GENERAL SHEET NOTES

1. THIS SITE MUST IMPLEMENT APPLICABLE PORTIONS OF THE STATE STORM WATER BEST MANAGEMENT PRACTICES MANUAL FOR CONSTRUCTION TO THE MAXIMUM EXTENT PRACTICABLE TO PREVENT EROSION AND SEDIMENT FROM ENTERING THE STORM DRAIN SYSTEM. FAILURE TO UTILIZE ADEQUATE CONTROL IS A VIOLATION OF BMC 17.20. A COPY OF THE MANUAL IS AVAILABLE UPON REQUEST AT THE PERMIT SERVICE CENTER AND AVAILABLE ONLINE AT [www.cabmphandbooks.com](http://www.cabmphandbooks.com)
2. CONTRACTOR TO OBTAIN A SEPARATE PUBLIC WORKS ENGINEERING PERMIT FROM THE PERMIT SERVICE CENTER FOR ALL WORK IN THE PUBLIC RIGHT OF WAY.
3. ANY SIDEWALK THAT IS IN DISREPAIR SHALL BE REPLACED IN ACCORDANCE WITH CITY OF BERKELEY STANDARDS, (BMC 16.04.010), "SIDEWALK REPAIR REQUIREMENTS". PRIOR TO FINAL CONTRACTOR & ARCHITECT SHOULD CONTACT AN ENGINEERING INSPECTOR AT 981-7500 TO SCHEDULE AN APPOINTMENT TO REVIEW SIDEWALK CONDITIONS TO DETERMINE WHETHER OR NOT REPLACEMENT/ REPAIR AND/ OR ALTERATION IS REQUIRED.
4. WALKWAYS ALONG ACCESSIBLE ROUTE OF TRAVEL (1) ARE CONTINUOUSLY ACCESSIBLE, (2) HAVE MAXIMUM 1/2" CHANGES IN ELEVATION, (3) ARE MINIMUM 48" IN WIDTH, (4) HAVE MAXIMUM 1/4" PER FOOT CROSS SLOPES, (5) HAVE MAXIMUM 5% (1:20) RUNNING SLOPES.
5. EXISTING COMPLYING ACCESSIBLE RAMP (SEE DETAIL 8/A0.1)

BERKELEY JCC  
FEMA UPGRADES

1414 Walnut Street  
Berkeley, CA 94709

11.19.2018 LPC AND AUP SUBMITTAL

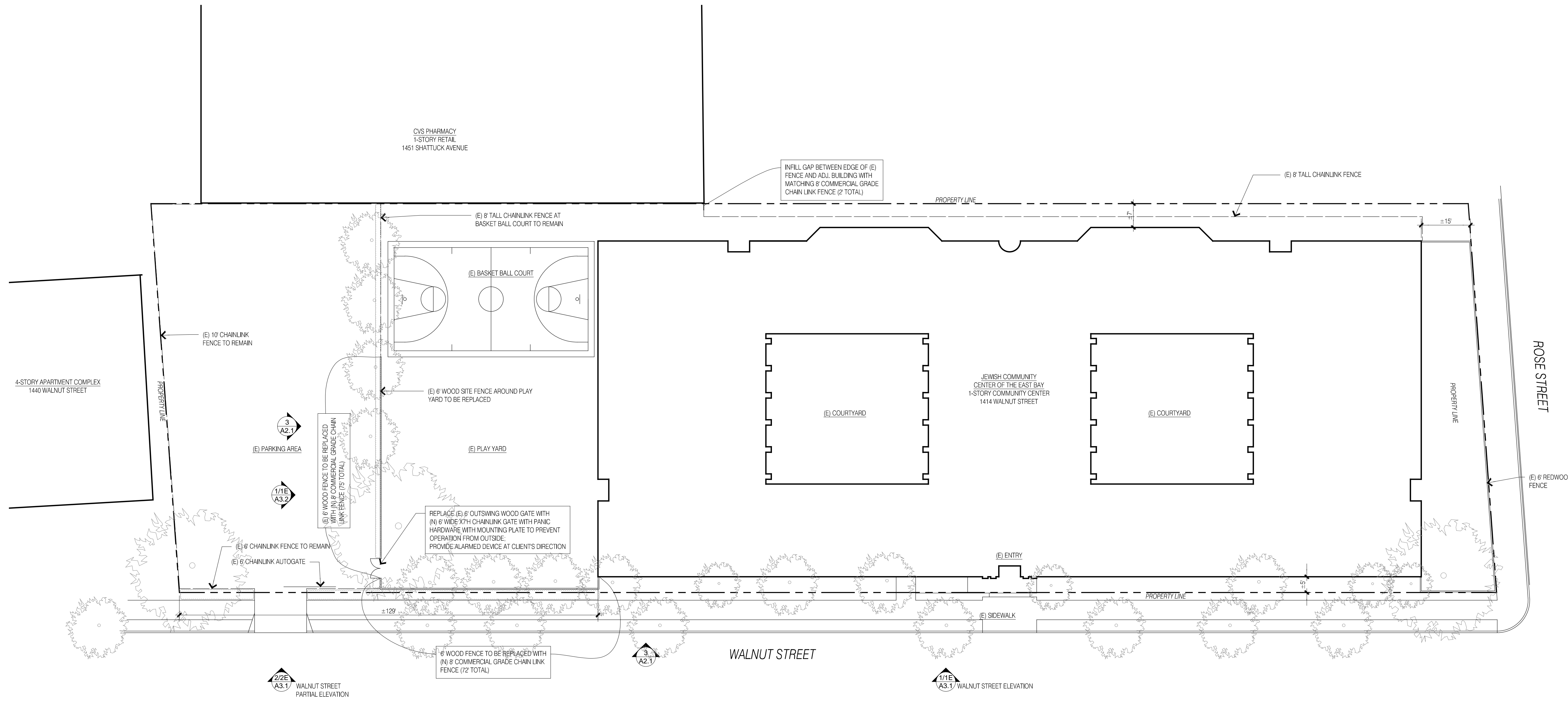

ALL DRAWINGS AND WRITTEN MATERIAL APPEARING HEREIN CONSTITUTE ORIGINAL AND UNPUBLISHED WORK OF THE ARCHITECT AND MAY NOT BE DUPLICATED, USED OR DISCLOSED WITHOUT WRITTEN CONSENT OF TRACHTENBERG ARCHITECTS.

JOB: - DRAWN BY:  
SCALE: - DATE:

SHEET:  
SITE PLAN

1 SITE PLAN  
1/16" = 1'-0"

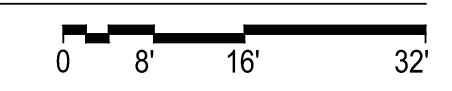

A1.1

TRACHTENBERG  
ARCHITECTS

2421 Fourth Street  
Berkeley, California 94710  
510.649.1414  
www.TrachtenbergArch.com



### BERKELEY JCC FEMA UPGRADES

1414 Walnut Street  
Berkeley, CA 94709

11.19.2018 LPC AND AUP SUBMITTAL

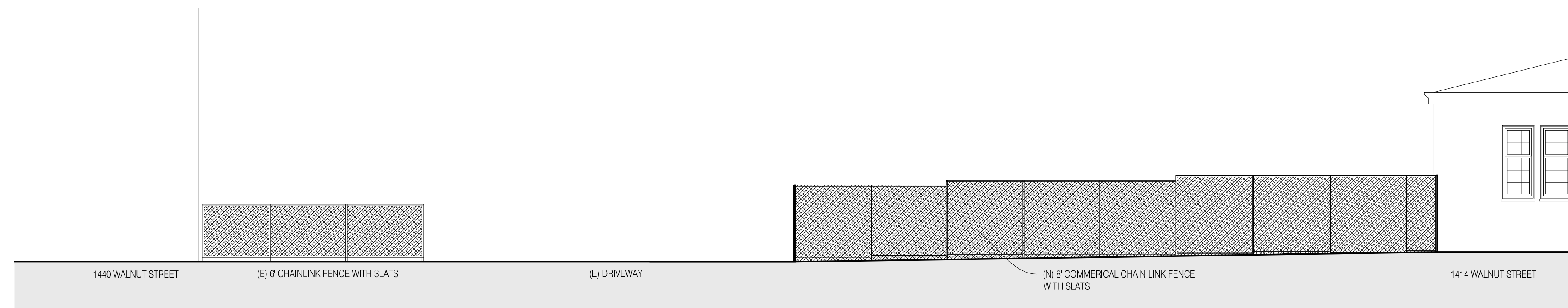

2  
-  
PARTIAL PROPOSED ELEVATION - WALNUT STREET  
1/16"=1'-0"

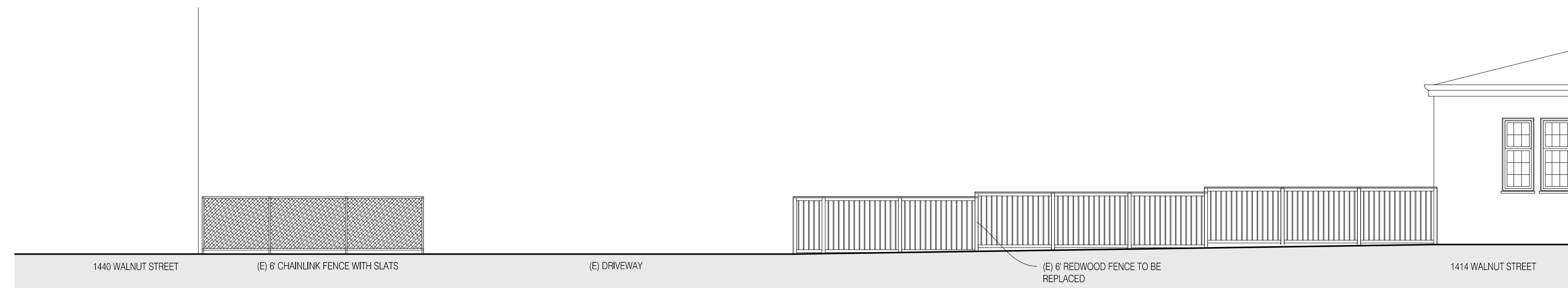
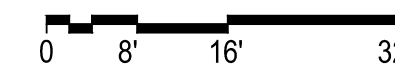

2E  
-  
PARTIAL EXISTING ELEVATION - WALNUT STREET  
1/16"=1'-0"

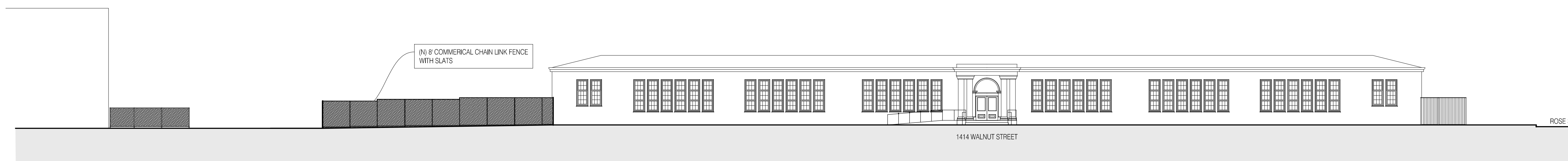
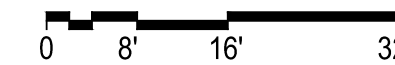

1  
-  
PROPOSED ELEVATION - WALNUT STREET  
1/16"=1'-0"

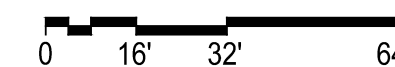

1E  
-  
EXISTING ELEVATION - WALNUT STREET  
1/16"=1'-0"

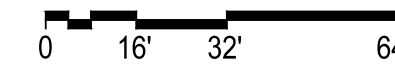

ALL DRAWINGS AND WRITTEN MATERIAL APPEARING  
HEREIN CONSTITUTE ORIGINAL AND UNPUBLISHED  
WORK OF THE ARCHITECT AND MAY NOT BE  
DUPLICATED, USED OR DISCLOSED WITHOUT  
CONSENT OF TRACHTENBERG ARCHITECTS.

JOB: - DRAWN BY:  
SCALE: - DATE:

SHEET:  
EXTERIOR ELEVATIONS  
WALNUT STREET

# A3.1





2 CHAINLINK FENCE WITH BROWN SLATS

TRACHTENBERG  
ARCHITECTS

2421 Fourth Street  
Berkeley, California 94710  
510.649.1414  
www.TrachtenbergArch.com



BERKELEY JCC  
FEMA UPGRADES

1414 Walnut Street  
Berkeley, CA 94709

11.19.2018 LPC AND AUP SUBMITTAL

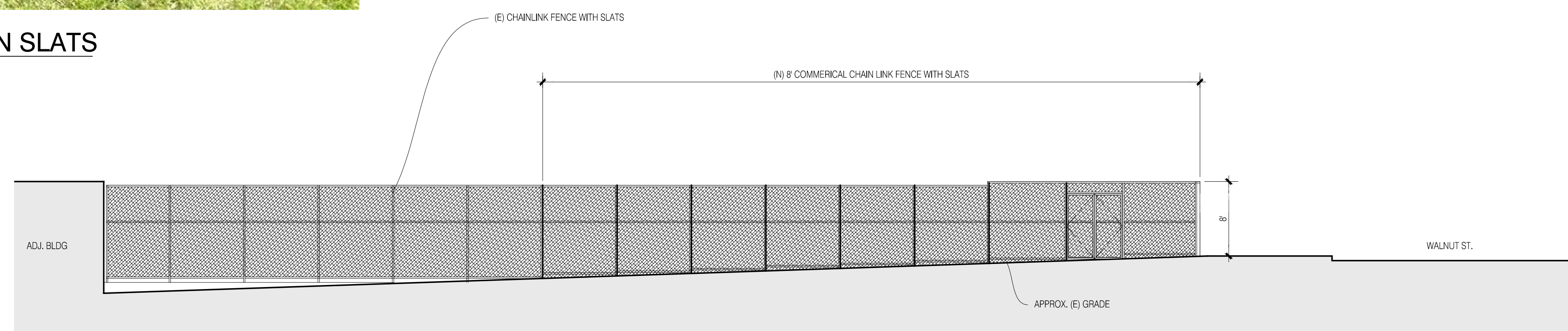

1 PARTIAL PROPOSED ELEVATION - SOUTH  
1/16" = 1'-0"

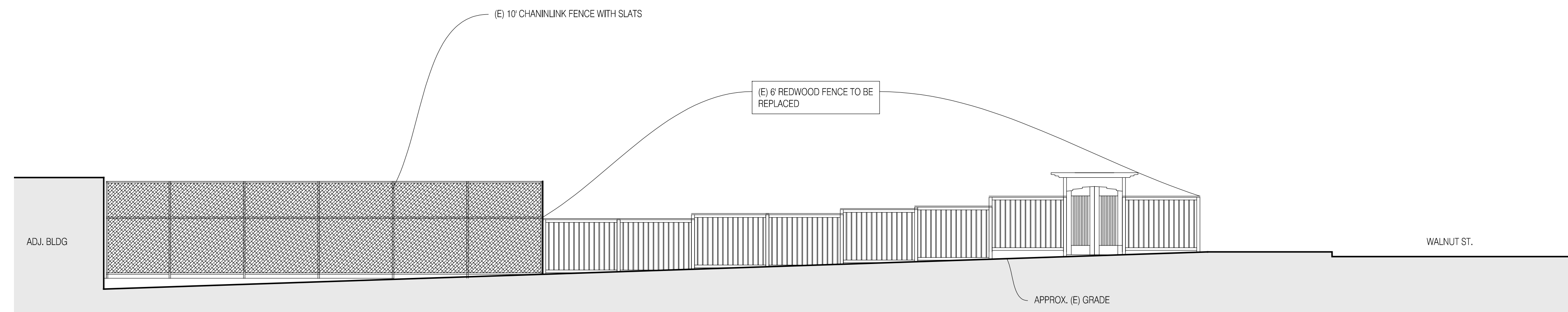

1E PARTIAL EXISTING ELEVATION - SOUTH  
1/16" = 1'-0"

ALL DRAWINGS AND WRITTEN MATERIAL APPEARING  
HEREIN CONSTITUTE ORIGINAL AND UNPUBLISHED  
WORK OF THE ARCHITECT AND MAY NOT BE  
DUPLICATED, USED OR DISCLOSED WITHOUT WRITTEN  
CONSENT OF TRACHTENBERG ARCHITECTS.

JOB: - DRAWN BY:  
SCALE: - DATE:

SHEET:  
EXTERIOR ELEVATIONS  
SOUTH

A3.2



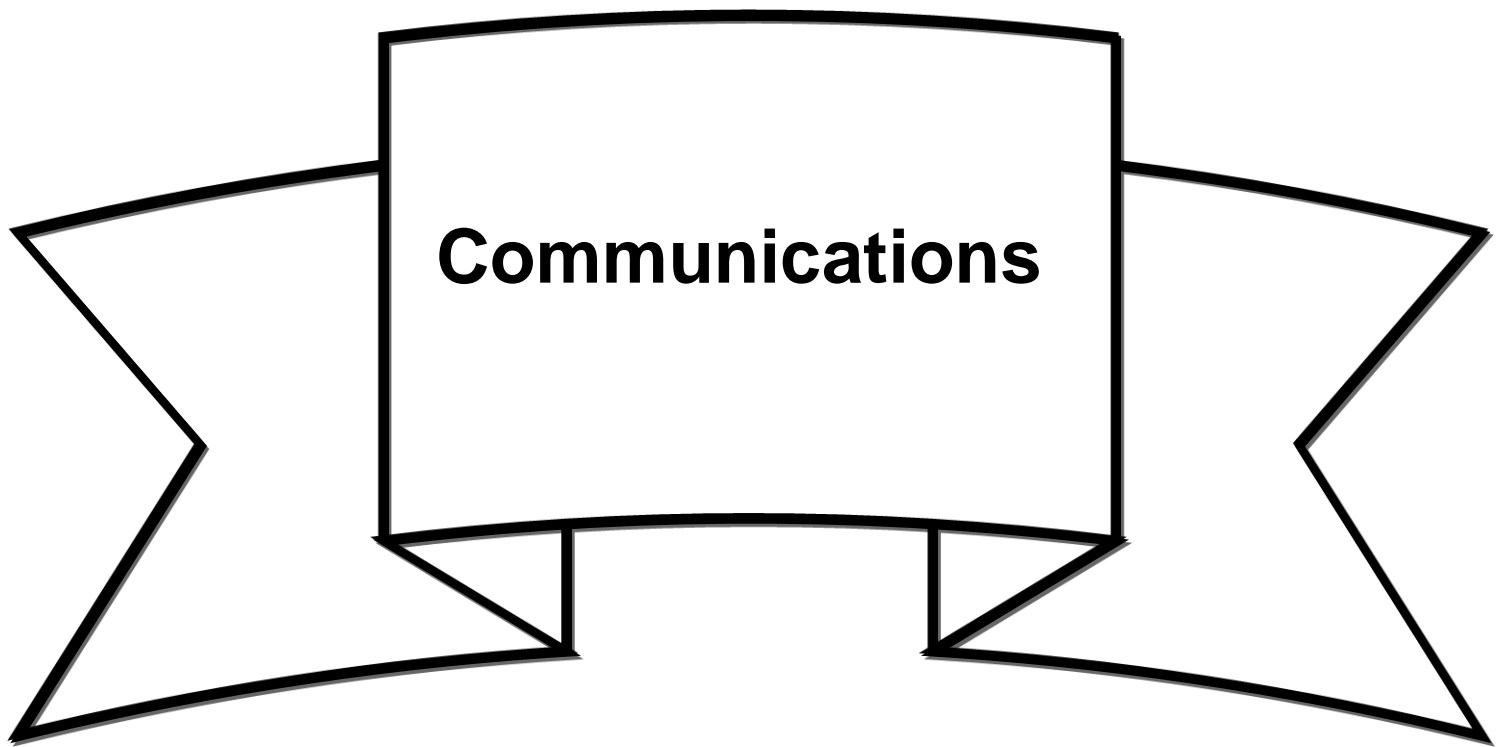

All communications submitted to the City Council are public record. Communications are not published directly to the City's website. Copies of individual communications are available for viewing at the City Clerk Department and through Records Online.

**City Clerk Department**

2180 Milvia Street  
Berkeley, CA 94704  
(510) 981-6900

**Records Online**

<http://www.cityofberkeley.info/recordsonline>

To search for communications associated with a particular City Council meeting using Records Online:

1. Select Search Type = “Public – Communication Query (Keywords)”
2. From Date: Enter the date of the Council meeting
3. To Date: Enter the date of the Council meeting (this may match the From Date field)
4. Click the “Search” button
5. Communication packets matching the entered criteria will be returned
6. Click the desired file in the Results column to view the document as a PDF